

FAHRZEUGTEILE & ZUBEHÖR
SPARE PARTS & ACCESSORIES



MGB / MGC
Roadster & GT

MGB & MGC

► **Bitte bei allen Bestellungen Kunden- und Artikel-Nummer angeben !**

PS: Die Preise für unsere Produkte finden Sie in der separaten Preisliste ganz leicht mit Hilfe der Artikelnummer. Bestellen können Sie per Telefon oder Fax, per Post oder ganz bequem per eMail.

Hilfreiche Hinweise für eine schnelle Bearbeitung Ihrer Bestellung finden Sie ebenfalls in der Preisliste.

► **Note: when ordering please ensure article and client number !**

PS : A few advices for your order: The pricing for our products are listed in the separate price list. Here you can get the pricing with the reference number easily. You can order per Post, Telephone, Telefax or very comfortable via E-Mail. Shipment will be made on the cheapest way without extra charge for packing. You will be charged only the delivery costs. Find more details to shipment and handling in the separate price list.

**Hinweise /
Notes**



Fahrtrichtung /
Sense of direction

- Linke oder rechte (Fahrzeug) Seite
= in Fahrtrichtung gesehen

Left or right side (of the car)
= in sense of direction

- AT-Teile = Austauschteile
Exch.. = parts for exchange

- Anzahl/Qty. = benötigte Anzahl / quantity required
A/R = Anzahl auf Anfrage / quantity at request
1/1 = Bsp.: 1 Artikel pro Seite / 1 piece per side

- **ACHTUNG:** Elektroteile und Literatur sind vom Umtausch ausgeschlossen!
ATTENTION: electrical parts and litterature are not returnable !

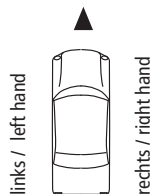

		Seite / Page
Motorteile / Zylinderkopf	Engine / Cylinder Head	4
Ölkühler und -filter, Zusatzlüfter	Oil Cooler & Filter, Electric Fan	16
Motor- und Getriebeaufnahme	Engine & Gearbox Mountings	18
Edelstahl Auspuffanlagen	Stainless Exhaust Systems	20
Luftfilter, Ansaugbrücke	Air Filter, Manifold	22
Vergaser	Carburettor	24
Gas- und Chokezug	Accelerator & Choke Control	30
Rennsport & Motortuning	Racing & MotorTuning	31
Benzinpumpe / Tankanlage	Petrol Pump / Tank	36
Kühlanlage	Cooling System	38
Heizung	Heater	40
Kupplung	Clutch	42
Getriebe	Gearbox	44
Overdrive	Overdrive	52
Hinterachse Federung	Rear Spring & Fittings	56
Differential	Differential	58
Vorderachse / Stabilisator	Front Suspension / Anti Roll Bar	62
Lenkung	Steering	68
Lenkräder	Steering Wheels	70
Felgen / Accessoires	Rims / Accessories	72
Bremsanlage	Brake System	76
Zündung / Verteiler	Ignition / Distributor	82
Anlasser / Lichtmaschine / Relais	Starter Motor / Generator / Relais	84
Schalter	Switches	86
Kabelbaum	Wiring Loom	90
Beleuchtung	Lights	92
Gummistopfen / Kabeltüllen	Rubber Plugs / Cable Spouts	95
Scheibenwaschanlage	Wiper & Washer System	96
Zusatzinstrumente	Instrumets	98
Tacho- und Drehzahlmesserwellen	Speedo Cables	99
Armaturenbrett und Konsole	Dashboard and Console Panels	100
Karosserieteile	Body Panels	102
Verdeck / Verdeckabdeckung	Hood / Tonneau Cover	106
Innenausstattung	Upholstery	110
Scheiben- und Gummitteile / Chromteile	Windscreen / Glasses & Body Finishers	120
Tür - Seitenscheiben / Mechanismus	Door- Glasses / Locks & Fittings	122
Kühlergrill	Front Grill	126
Stoßstangen	Front & Rear Bumper	128
Kofferraum / Heckklappe..	Boot Lid Seals & Finishers	130
Motorhaube / Chrom & Gummitteile	Bonnet Panels, Seals & Finishers	132
Embleme	Badges	133
Motor MGC	Engine MGC	134
Elektrische Anlage MGC	Electrical MGC	139
Edelstahl Auspuffanlagen MGC	Stainless Exhaust Systems MGC	140
Kühlanlage MGC	Cooling System MGC	142
Kupplung MGC	Clutch MGC	144
Hinterachse MGC	Rear Suspension MGC	146
Lenkung MGC	Steering MGC	147
Vorderachse MGC	Front Suspension MGC	148
Bremsanlage MGC	Brake System MGC	152
Accessoires / Team Bastuck	Accessories / Team Bastuck	156
Literatur	Literature	158
Werkzeug u. Hilfsmittel	Tools and externals	160
Pflege- und Schmiermittel	Care Products / Lubricants	161
Team BASTUCK Collection	Team BASTUCK Collection	162
Zollschrauben / -muttern	Screws / Nuts	163
Fahrzeugidentifikation / Technische Informationen	Car Specification / Technical Data	164
Austausch-, Altteile	Exchange Parts	169
Verkaufs- u. Lieferbedingungen	Terms & Conditions	171

No.	Bezeichnung	Description	Anzahl/Qty.
M01MGB-01	AT-Motor MGB1800 (63-64), 3-fach gelagert, bleifrei	Exch. engine MGB1800 (63-64), 3-main bearing, lead free	1
M01MGA-12	Nockenwelle	Camshaft	1
M03MGA-12	Nockenwelle-Lager-Satz	Camshaft bearing set	1
M03MGA-10	Buchse Kurbelwelle	Bush crankshaft spigot	1
M04MGA-10	Kettenrad Kurbelwelle Duplex	Sprocket crankshaft Duplex	1
M04MGA-12	Klemmkeil Nockenwelle	Key woodruff camshaft	1
M05MGA-12	Halteblech Nockenwelle	Plate retaining camshaft	1
M05MGA-10	Keil Kurbelwelle	Key crankshaft	2
M06MGA-10	Ölschleuderblech	Oil thrower	1
M09MGA-12	Stösseltasse	Cam follower	8
M10MGA-12	Stößelstange	Push rod	8
K16MGB-12	Wasserpumpe	Water pump	1
K16CMGA-12	Wasserpumpendichtung	Sealing water pump	1
M19MGA-10	Pleuellager-Satz 3-fach gelagert *)	Big end bearings set 3-mains *)	1
M19MGA-12	Korkdichtstreifen-Hauptlager	Main cap cork gasket	2
M25AMGB	Leichte Stahlschwungscheibe zum Ersatz der Serienschwungscheibe	Lightweight steel flywheel to replace the original flywheel	1
M27AMGA-12	Verschlußstopfen	Plug	1
M27MGA-12	Ablasshahn Kühlwasser/Motor	Drain tap engine	1
M27MGB-01	Kolben-Satz 18G-GA *)	Piston set 18G-GA *)	1
M28MGB-01	Kolbenringe-Satz bis 18G-GA *)	Piston rings set up to 18G-GA *)	1
M28MGA-12	Fiberscheibe 1/2 x 3/4"	Washer (fibre) 1/2 x 3/4"	4
M31MGA-10	Sicherungsblech Pleuelschraube	Tab washer connecting rod bolt	4
M31MGA-08	Stehbolzen Zylinderkopf MGB lang	Stud cylinder head mgb long	7
M32MGA-08	Stehbolzen Zylinderkopf MGB kurz	Stud cylinder head short	8
M32MGA-10	Pleuelschraube	Con rod bolt	1
M34MGA-12	Sicherungsblech Keilriemenscheibe	Pulley bolt lock tab	1
M36MGA-12	Hutmutter Öldruckventil	Cap nut oil pressure valve	1
M38MGA-12	Feder Öldruckventil	Spring oil pressure valve	1
M39MGA-12	Überdruckventil Öldruck	Oil pressure relief valve	1
M39MGA-10	Anlasser-Zahnkranz Schwungscheibe	Starter gear ring on flywheel from	3
M40MGA-10	Sicherungsblech Schwungscheibe 3-Lager	Washer lock flywheel 3-bear.	1
M40MGA-11	Dichtung Kettenspanner	Gasket timing chain tensioner	6
M41MGA-10	Bolzen Schwungscheibe	Bolt pulley crankshaft/flywheel	1
M41MGA-11	Kettenspanner	Timing chain tensioner	4
FSF41	Froststopfen Motorblock (41 mm)	Core plug engine block (41 mm)	1
M42MGA-11	Sicherungsblech Kettenspanner	Lock tab chain tensioner	1
M45MGA-11	Steuerkette Duplex	Timing chain early duplex	1
M46MGA-11	Nockenwelle-Zahnrad Duplex	Camshaft gear duplex	1
M47MGA-11	Sicherung-Scheibe	Lock washer	2
M47MGB-11	Pleuel Nr. 2 + 4	Con rod no 2 + 4	2
M47AMGB-11	Pleuel Nr. 1 + 3	Con rod no 1 + 3	1
M47MGB	Schraube Hauptlagerdeckel (ersetzt frühe Stehbolzen)	Bold main bearing cap (replaces early stud)	6
M48MGA-11	Mutter Nockenwellenzahnkranz	Nut camshaft gear	1
M57MGB-01	Riemenscheibe Kurbelwelle	Pulley crankshaft	1
ZK65SPT	Mutter Zylinderkopf, Mutter Schwungscheibe	Cylinder head nut / nut to flywheel	11/6
ZK65SPTR	Mutter Zylinderkopf verstärkt	Cylinder head nut competition	11
ZK66SPTR	Unterlegscheibe Zylinderkopfmutter spezial hart	Plain washer under cylinder head nut, hardened	11
M67MGB-01	Anlaufscheiben-Satz *)	Thrust washer set *)	1
M68MGB-01	Hauptlager-Satz *)	Main bearings set *)	1
M74SPT	Dichtung	Washer sealing	1
M87MGB-01	AT-Kurbelwelle 18G/GA MGB 3-Lager	Exch. crankshaft 18G/GA MGB 3-bearing	1
MÖ	Motoröl 20W50, pro Liter	Motor oil 20W50, per liter	A/R

*) Bitte Größe angeben!

*) please refer dimension!

**Hinweis
Note:**

Austauschteile können grundsätzlich erst nach Eingang des Altteiles versandt werden. Diese sind immer vorab in komplettem und gereinigtem Zustand anzuliefern! **Beachten Sie bitte die Hinweise zu den Austauschmotoren auf Seite 169!**



As a matter of principle, parts which are available in exchange can only be dispatched after receipt of the old/used unit. Please supply us exchange parts complete and cleaned. **Please refer to our notes on page 169!**

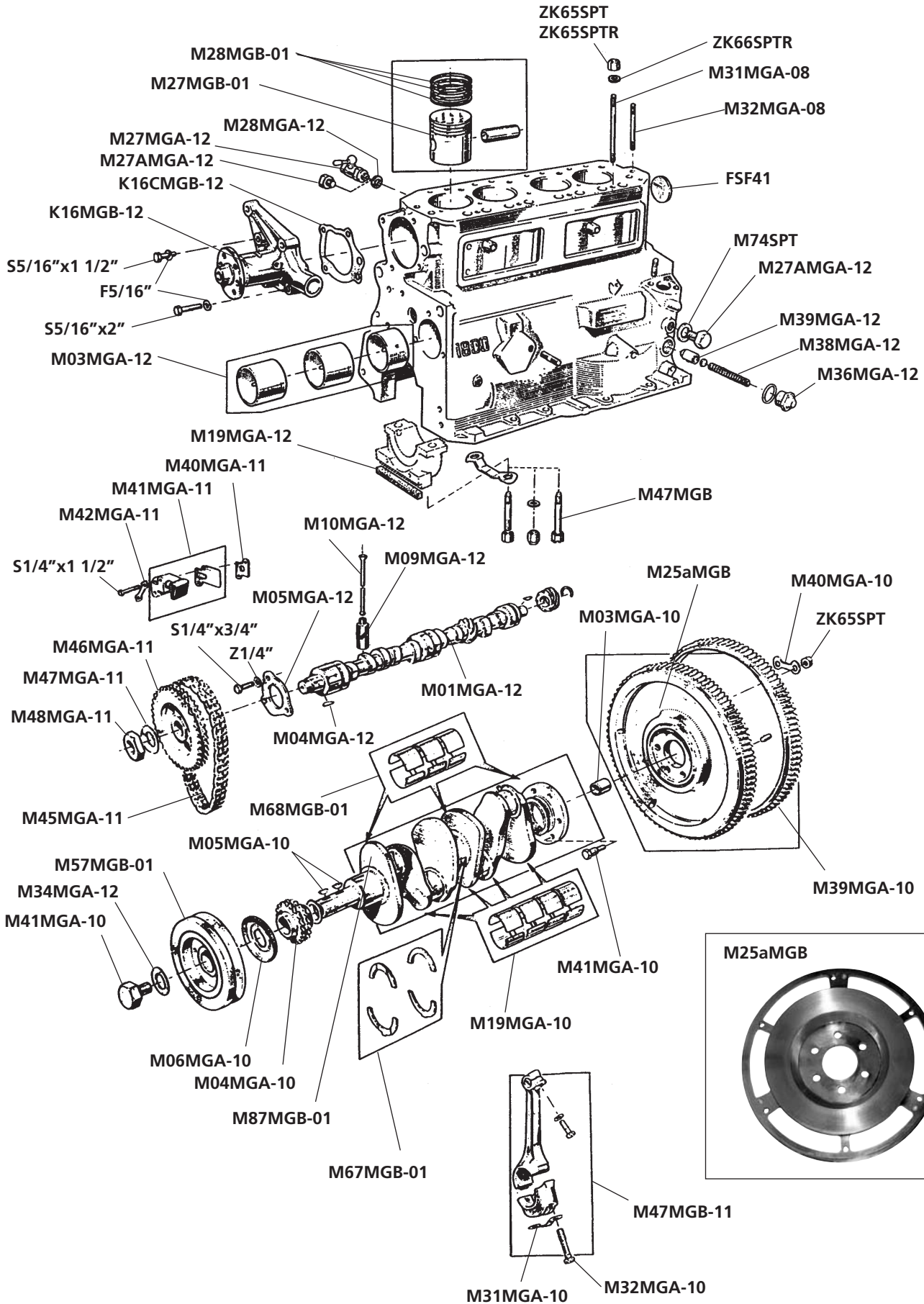

No.	Bezeichnung	Description	Anzahl/Qty.
M02MGA-13	Ölpeilstab	Oil dipstick	1
M03MGA-13	Führungsrohr Ölpeilstab	Dipstick tube	1
M04MGA-13	Gummi-Dichtung Ölmesstab	Rubber seal oil dipstick	1
M17MGA-12	Ölwannen-Dichtung MGB 3-Lager	Oil sump gasket MGB 3 bearing	1
M21MGA-12	Dichtung Steuerkettendeckel	Gasket timing chain cover	1
M23MGA-12	Simmerring Steuerdeckel	Oil seal timing chain cover	1
M24MGA-12	Dichtung Motorplatte vorne	Gasket engine mounting plate front	1
M25MGA-12	Ölablaßschraube	Oil drain plug	1
M29MGA-12	Anschluß Motorblock Öldruckinstrument	Union oil pressure gauge pipe	1
M30MGA-12	Dichtring	Washer oil/water drain plug	1
M31MGB-01	Motor-Seitendeckel mit Ölabscheider	Engine side cover with oil breather	1
M31AMGB-01	Gummi-Ring Motorseitendeckel	Rubber seal engine side cover	2
M31BMGB-01	Konkavscheibe Motor-Seitendeckel	Washer cup cover	1
M35MGA-11	Ölpumpe MGB 3-fach gelagerter Motor	Oil pump MGB 3-bearing engine	1
M37MGA-11	Sieb Ölpumpe	Strainer oil pump	1
M38MGA-11	Dichtung Ölpumpe/Gehäuse MGB 3-Lager	Gasket oil pump/crankcase MGB 3-bearing	1
M41MGA-12	Dichtung Motorseite Kork	Gasket engine side cover (cork)	2
M42MGA-12	Motor-Seitendeckel hinten	Engine side cover rear	1
M50MGA-11	Ölfiltreinsatz	Oil filter paper element	1
M51MGA-11	Stehbolzen Ölpumpe	Stud oil pump MGB	3
M60MGB-01	Steuerkettendeckel	Timing chain cover	1
M65MGB-01	Dichtung Motorplatte hinten	Gasket engine mounting plate/block	1
M74SPT	Dichtring Ölablassschraube	Sealing washer oil/water drain plug	1
M76BMGB-01	Motordicht-Satz unten	Engine gasket set bottom	1
M25MGA-13	Umrüst-Satz Einweg-Ölfilterpatrone (Adapter) *)	Spin on throw-away oil filter kit (Adaptor) *)	1
K33TR	Ölfilter für M25MGA-13	Oil filter to no. M25MGA-13	1
MÖ	Motoröl 20W50, pro Liter	Motor oil 20W50, per liter	A/R
MÖRACE	Motoröl 20W50 Racing für Sportzwecke, pro Liter	Motor oil 20W50 Racing for competition use, per liter	A/R
MD17SPT	Dauerplast. Universaldichtung "Marston" 80 ml	Universal jointing compound "Marston" 80 ml	A/R
MD17aSPT	Hochwertige Silikondichtmasse - schwarz "Hylosil" 200 ml	Silicone sealant - black "Hylosil" 200 ml	A/R

Hinweis
Note:

*) Anmerkung zu M25MGA-13:

Dieser Umrüstsatz auf eine Einweg-Ölfilterpatrone macht den regelmäßigen Ölwechsel zu einer sauberen, einfachen Angelegenheit. Unsere Einweg-Ölfilterpatrone K33TR ist zudem mit einem Rückschlagventil versehen, so dass beim Starten des Motors das Öl direkt den Lagern und nicht mehr dem Ölfilter zuerst zugeführt wird!

*) Note to no. M25MGA-13:

The use of a „Spin-on“-oil filter will make routine oil changing much cleaner and easier operation. Our „Spin-on“-oil filter no. K33TR has a internal anti-drain valve to prevent the oil draining back into the sump after starting the engine; oil flows directly to the bearings and not first into the oil filter anymore!

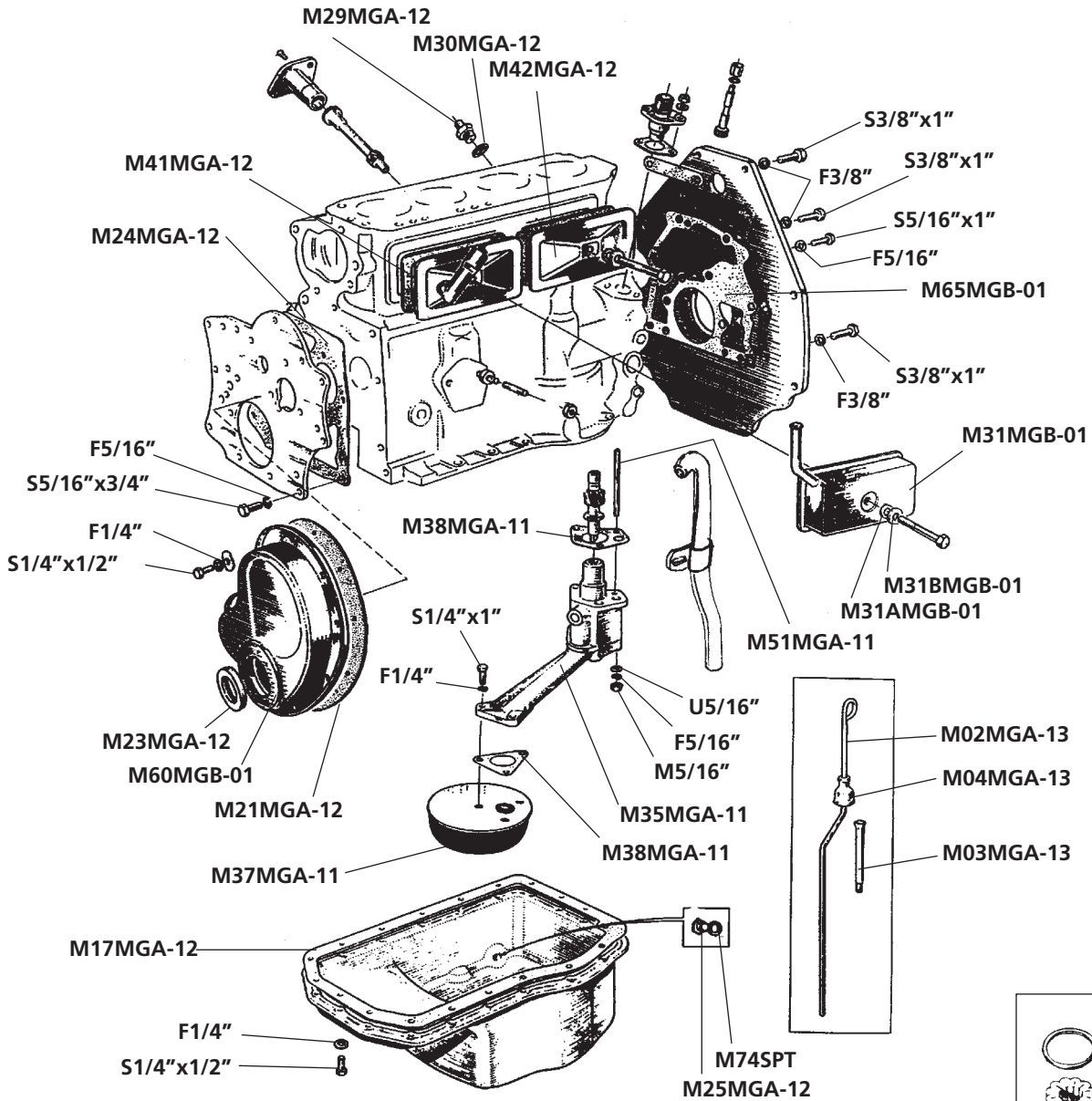

MD17ASPT



M76BMGB-01

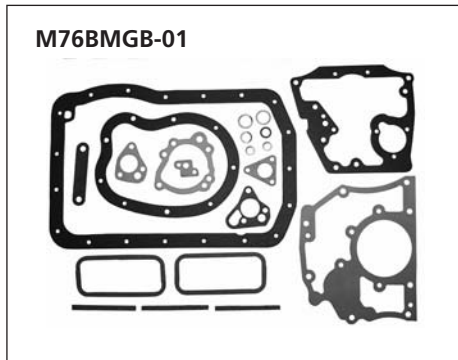

M50MGA-11

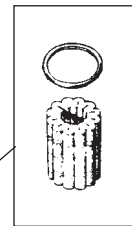

K33TR



MD17SPT

Ölfilter und Umrüstsatz siehe auch Seite 16-17
Oil filter/spin on and throw away oli filter kit
see page 16-17 in this catalogue

No.	Bezeichnung	Description	Anzahl/Qty.
ZK1MGB/18G	AT-Zylinderkopf 18G,18GA,18GB,18GD,18GG	Exchange cylinder head 18G,18GA,18GB,18GD,18GG	1
ZK01MGA-09	Einstellschraube Ventile	Adjusting screw tappet adjusting	8
K4SPT	Thermostat 74°C	Thermostat 74°C	1
K4ASPT	Thermostat 82°C	Thermostat 82°C	1
ZK05MGA-09	Feder zwischen Kipphebel	Spring rocker spacing	3
ZK05MGB-01	Ventilfeder Set (16x)	Valve spring set (16x)	1
ZK05MGA-08	Stehbolzen kurz	Manifold stud short	2
ZK06MGA-08	Stehbolzen lang	Manifold stud long	4
ZK06MGA-09	Lagerbock Kipphebelwelle	Bracket rocker shaft	1
ZK07MGA-09	Lagerbock Kipphebelwelle flach	Bracket rocker shaft plain	3
ZK08MGA-08	Öleinfülldeckel	Oil filler cap	1
ZK08AMGA-08	Öleinfülldeckel chrom	Oil filler cap chrome	1
ZK08MGA-09	Schraube Kipphebelwelle	Screw locating rocker shaft	1
ZK85SPT	Mutter Ventileinstellscharube	Nut valve fixing	8
ZK09MGA-09	Haltescheibe	Plate locking	1
ZK09MGB-01	Öleinfülldeckel Kunststoff	Oil filler cap plastic	1
ZK09MGA-08	Ventildeckel-Dichtung	Rocker cover gasket	1
ZK10MGA-08	Ventildeckel-Mutter	Nut rocker cover retaining	2
ZK11MGA-09	Klemmkeil Ventil, frühe Ausführung	Valve cotter, early	8
ZK12MGA-08	Scheibe Ventildeckelmutter	Washer rocker cover nut	2
ZK13MGA-09	O-Ring Ventilschaft	O-ring valve shaft	8
ZK14MGA-09	Obere Ventilfederkappe bis 18GD0835	Upper valve cup up to 18GD0835	8
ZK14MGA-08	Unterlegscheibe Ventildeckelmutter	Washer rocker cover nut	2
ZK16MGA-08	Gummi-Dichtring Ventildeckel	Rubber washer rocker cover	2
ZK18MGA-09	Unterlage Ventilfeder	Collar valve spring lower	8
ZK18AMGB-01	Ventildeckel-Mutter verchromt	Rocker cover retaining nut chromed	2
K21MGA-15	Thermostatgehäuse	Thermostat housing	1
A21MGA-14	Scheibe Auspuffkrümmer	Manifold yoke	4
K22MGA-15	Thermostatdichtung	Gasket thermostat housing	1
ZK23MGA-09	Ventilführung Einlass	Inlet valve guide	4
ZK20MGA-09	Ventil Einlass MGB *)	Inlet valve MGB *)	4
ZK21MGA-09	Auslassventil MGB *)	Exhaust valve MGB *)	4
ZK24MGA-08	Stehbolzen Thermostatgehäuse	Stud thermostat housing	3
K25MGA-32	Dichtung	Gasket	1
A25MGA-14	Mutter Auspuffkrümmer	Nut exhaust manifold	6
ZK25MGA-09	Ventilführung Auslass	Valve guide exhaust	4
M26MGB-01	Zylinderkopf-Dichtung	Cylinder head gasket	1
M26CMGB-02	Zylinderkopf-Dichtsatz	Cylinder head gasket set	1
ZK27MGA-09	Ventilführungen Satz, Bronze	Valve guides set bronze	1
ZK31MGA-08	Stehbolzen Kipphebelwelle lang	Stud rocker cover long	2
ZK32MGA-08	Stehbolzen Kipphebelwelle kurz	Stud rocker cover short	2
ZK33MGA-08	Kipphebelwelle	Rocker shaft	1
ZK36MGA-08	Kipphebel	Rocker arm	8
ZK37MGA-08	Kipphebelbuchse	Rocker bush	8
ZK38MGA-08	Einlass/Auslassdichtung	Gasket inlet/exhaust	1
ZK51MGA-09	Klammer Ventilkeile	Clip valve collets	8
ZK90MGB-01	Ventildeckel	Rocker cover	1
ZK07MGA-08	Ventildeckel Aluminium poliert	Rocker cover alloy polished	1
MÖ	Motoröl 20W50, pro Liter	Motor oil 20W50, per liter	A/R
MÖRACE	Motoröl 20W50 Racing für Sportzwecke, pro Liter	Motor oil 20W50 Racing for competition use, per liter	A/R
MD17SPT	Dauerplast. Universaldichtung "Marston" 80 ml	Universal jointing compound "Marston" 80 ml	A/R
MD17aSPT	Hochwertige Silikondichtmasse - schwarz "Hylosil" 200 ml	Silicone sealant - black "Hylosil" 200 ml	A/R

*) Bitte Größe angeben!

*) please refer dimension!

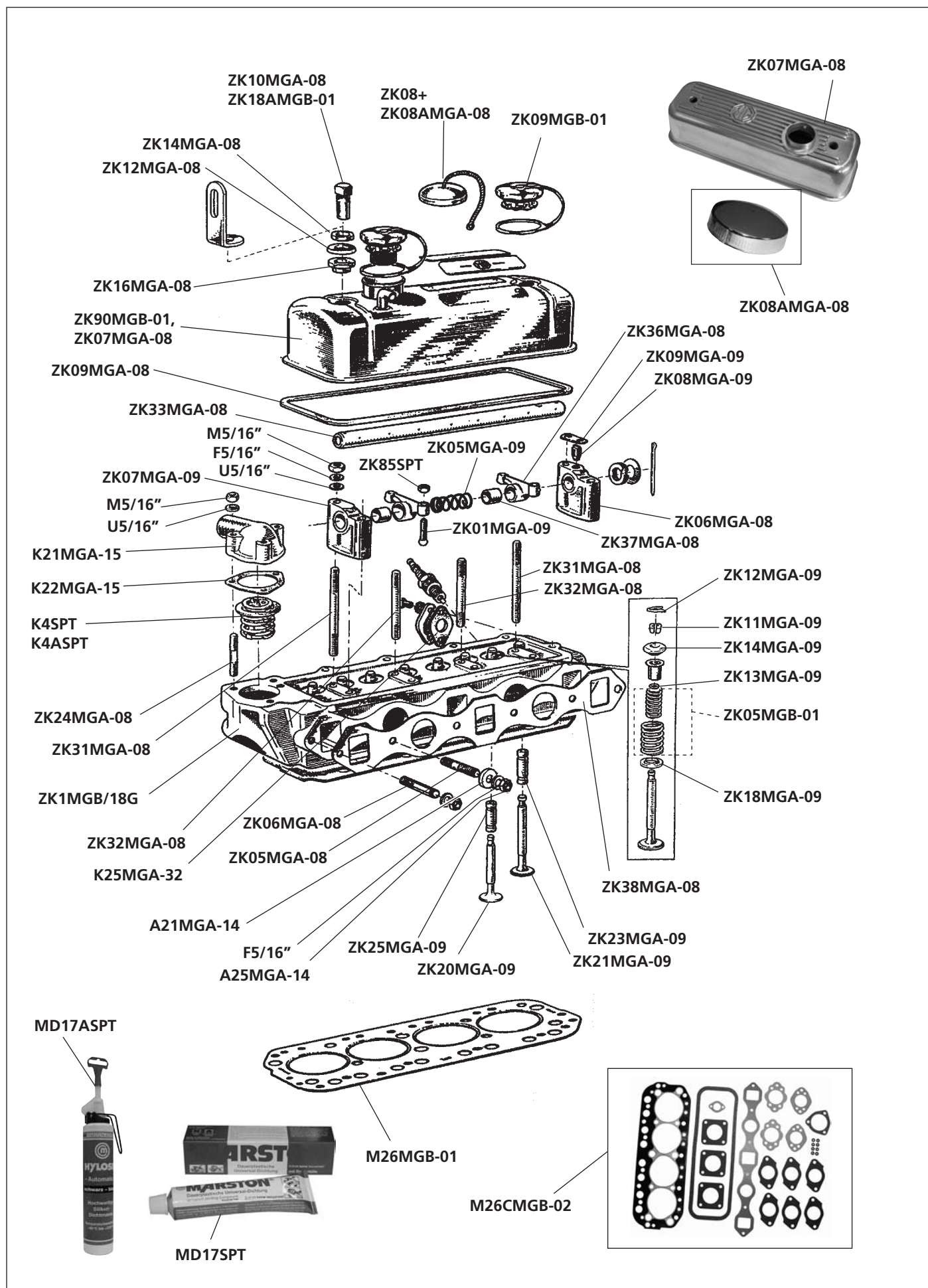

No.	Bezeichnung	Description	Anzahl/Qty.
M01MGB-02	AT-Motor MGB1800 18GB, 64-67 bleifrei	Exch. engine MGB1800 18GB, 64-67 lead free	1
M01AMGB-02	AT-Motor MGB1800 18GG, 64-67 bleifrei	Exch. engine MGB1800 18GG, 64-67 lead free	1
M01BMGB-02	AT-Motor MGB1800 18V, 71-74 bleifrei (Chromstoßst.modell)	Exch. engine MGB1800 18V, 71-74 lead free (chrome bumper)	1
M01CMGB-02	AT-Motor MGB1800 18V, 75-80 bleifrei (Gummistoßstange)	Exch. engine MGB1800 18V, 75-80 lead free (rubber bumper)	1
M03MGA-12	Nockenwelle-Lager-Satz	Camshaft bearing set	1
M04MGA-12	Klemmkeil Nockenwelle	Key woodruff camshaft	1
M04MGA-10	Kettenrad Kurbelwelle Duplex	Sprocket crankshaft Duplex	1
M05MGA-10	Keil Kurbelwelle bis 18V.58 13105	Key crankshaft up to 18V.58 13105	2
M05MGB-10	Keil Kurbelwelle 18V Motor	Key crankshaft 18V engine	2
M05MGA-12	Halteblech Nockenwelle	Plate retaining camshaft	1
M09MGB-02	Stösselstange ab 18V	Push rod up from 18V	8
M09MGA-12	Stösselstange bis 18V	Push rod up up to 18V	8
M10MGA-12	Stösselstange bis 18V 0101	Push rod up to 18V 0101	8
M10MGB-02	Stösselstange ab 18V 0101	Push rod from 18V 0101	8
MD13SPTMK4	Dichtung	Gasket	1
M19MGA-12	Dichtstreifen Hauptlager bis 70	Main cap gasket up to 71	2
M19MGB-12	Dichtstreifen-Hauptlager 18V ab 71	Main cap gasket 18V from 71	2
M20AMGB-02	Pleuelbüchse	Bush	4
M20MGB-02	Pleuel aufgearbeitet, abgewinkelt 18GB Motor	Con rod rebuild 18GB engine	4
M21MGB-02	Pleuel aufgearbeitet, gerade 18GG-18V Motor	Con rod rebuild 18GG-18V engine	4
M22MGB-02	Pleuel aufgearbeitet, gerade 18V Motor	Con rod rebuild 18V engine	4
M25BMGB	Leichte Stahlschwungscheibe	Lightweight steel flywheel	1
M26AMGA-12	Dichtung GB Motor	Washer sealing GB engine	1
M27AMGA-12	Verschlußstopfen GB Motor	Plug blanking GB engine	1
M27MGA-12	Ablasshahn Kühlwasser/Motor	Drain tap engine	1
M27MGB-02	Kolben-Satz 18GB bis GG, CR 8.75:1 (bis 70) *)	Piston set 18GB up to GG, C R8.75:1 (up to 70) *)	1
M27AMGB-02	Kolben-Satz 18V, CR 8.75:1 (ab 71) *)	Piston set 18V, CR 8.75:1 (from 71) *)	1
M27BMGB-02	Kolben-Satz 18V, CR 8.00:1 (USA ab 71) *)	Piston set from 18V, CR 8.00:1 (USA from 71) *)	1
M28MGB-02	Kolbenringe-Satz 18GB - GG (4 Ringe) *)	Piston rings set 18GB - GG (4 rings) *)	1
M28AMGB-02	Kolbenringe-Satz ab 18V alle Modelle (3 Ringe) *)	Piston rings set from 18V all models (3 rings) *)	1
M28MGA-12	Fiberscheibe 1/2 x 3/4"	Washer (fibre) 1/2 x 3/4"	1
M31MGA-10	Sicherungsblech Pleuelschraube	Tab washer connecting rod bolt	4
ZK31MGA-08	Stehbolzen Zylinderkopf lang	Stud cylinder head long	4
ZK32MGA-08	Stehbolzen Zylinderkopf kurz	Stud cylinder head short	7
M32MGA-10	Pleuelschraube für M20MGB-02	Con rod bolt for no. M20MGB-02	8
M32MGB-10	Pleuelbolzen für M21+M22MGB-02	Bolt big end for no. M21+M22MGB-02	8
M32AMGB-10	Mutter Pleuelschraube für M21+M22MGB-02	Nut con rod for no. M21+M22MGB-02	8
M34MGA-12	Sicherungsblech Keilriemenscheibe	Pulley bolt lock tab	1
M36MGA-12	Hutmutter Öldruckventil	Cap nut oil pressure valve	1
M37MGA-12	Kupferscheibe	Copper washer	1
M38MGA-12	Feder Öldruckventil	Spring oil pressure valve	1
M39MGA-12	Überdruckventil Öldruck	Oil pressure relief valve	1
M39MGA-10	Anlasser-Zahnkranz 3-Synchro Getriebe bis 67	Starter gear ring 3-synchro bis 67	1
M39MGB-10	Anlasser-Zahnkranz 4-Synchro Getriebe ab 67	Starter gear ring 4-synchro from 67	1
M40MGA-11	Dichtung Kettenspanner	Gasket timing chain tensioner	1
M41MGA-11	Kettenspanner	Timing chain tensioner	1
FSF41	Froststopfen Motorblock (41 mm)	Core plug engine block (41 mm)	4
M42MGA-11	Sicherungsblech Kettenspanner	Lock tab chain tensioner	1
M45MGA-11	Steuerkette Duplex	Timing chain early duplex	1
M46MGA-11	Nockenwelle-Zahnrad Duplex	Camshaft gear duplex	1
M46MGB-02	Schwungscheibe-Befestigungs-Schraube	Flywheel screw	6
M47MGB-02	Sicherungsblech Schwungscheibe	Lock washer flywheel	1
M47MGA-11	Sicherung-Scheibe	Lock washer	1
M47MGB	Schraube Hauptlagerdeckel (ersetzt frühe Stehbolzen)	Bolt main bearing cap (replaces early stud)	10
M48MGA-11	Mutter Nockenwellenzahnkranz	Nut camshaft gear	1
M51MGB-02	Nockenwelle 5-Fach bis Bj. 76	Camshaft 5-bearing up to 76	1
M51AMGB-02	Nockenwelle ab 76 US	Camshaft from 76 US	1
M54MGB-02	Pleuellager-Satz *)	Big end bearings set *)	1
M61MGB-02	Zwischenstück Öldruckventil	Packing piece oil pressure valve	1

– Fortsetzung s. Seite 12

*) Bitte Größe angeben!

– to be continued on page 12

*) please refer dimension!

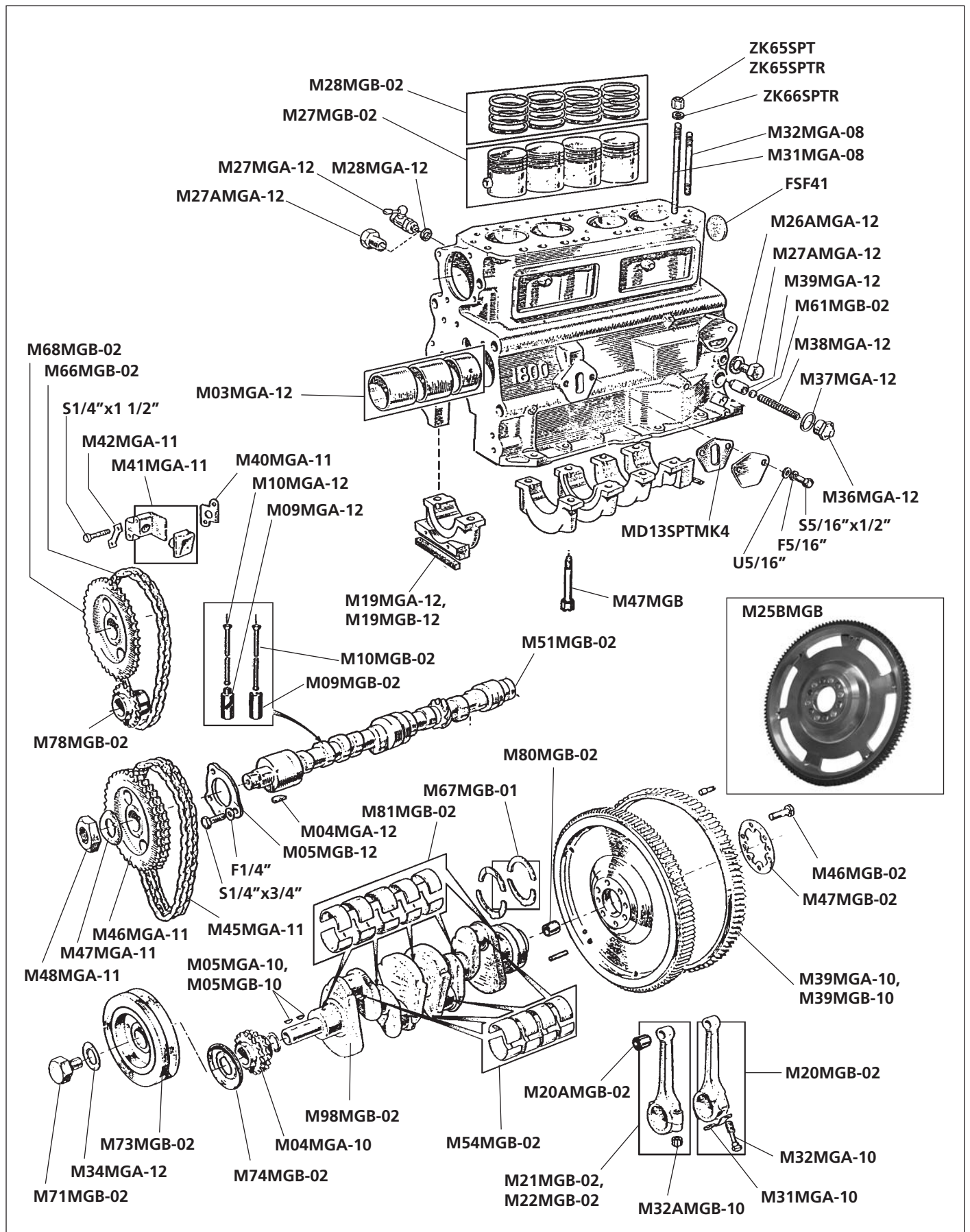

Hinweis 
Note:



Beachten Sie bitte die Hinweise zu den Austauschmotoren auf Seite 169!

Please refer to our notes "Exchange Parts" on page 169!

No.	Bezeichnung	Description	Anzahl/Qty.
	- Fortsetzung von Seite 10	- Continuation from page 10	
ZK65SPT	Mutter Zylinderkopf	Nut cylinder head	11
ZK65SPTR	Mutter Zylinderkopf verstärkt	Nut cylinder head competition	11
ZK66SPTR	Scheibe Zylinderkopfbolzen spezial hart	Plain washer cyl. head studs hardened	11
M66MGB-02	Steuerkette Simplex 18V Motor	Timing chain simplex 18V engine	1
M68MGB-02	Nockenwelle-Zahnrad Simplex 18V Motor	Camshaft gear simplex 18V engine	1
M71MGB-02	Bolzen Keilriemenscheibe	Bolt pulley crankshaft	1
M73MGB-02	Riemenscheibe Kurbelwelle bis 18GG.22442	Pulley crankshaft up to 18GG.22442	1
M73BMGB-02	Riemenscheibe Kurbelwelle ab 9/76	Pulley crankshaft from 9/76	1
M74MGB-02	Ölschleuderblech	Oil thrower	1
M78MGB-02	Kettenrad Kurbelwelle Simplex	Sprocket crankshaft Simplex	1
M80MGB-02	Buchse Kurbelwelle MGB 5-Lager	Bush crankshaft spigot MGB 5-bearing	1
M81MGB-02	Hauptlager-Satz *)	Main bearings set *)	1
M67MGB-01	Anlaufscheiben-Satz *)	Thrust washer set *)	1
M98MGB-02	AT-Kurbelwelle nitriert	Crankshaft exchange	1

*) Bitte Größe angeben!

*) please refer dimension!

No.	Bezeichnung	Description	Anzahl/Qty.
M02MGA-13	Ölmeßstab	Oil dipstick	1
M02AMGB-13	Ölmeßstab 18GG bis 18V 0672	Oil dipstick 18GG up to 18V 0672	1
M02BMGB-13	Ölmeßstab ab 18V 0673	Oil dipstick from 18V 0673	1
M03MGA-13	Führungsrohr Ölmeßstab bis 18GF	Dipstick, bent up to 18GF	1
M03MGB-13	Führungsrohr Ölmeßstab ab 18GG	Dipstick, bent from 18GG	1
M04MGA-13	Gummi Ölmeßstab	Gaiter, dipstick	1
MD13SPTMK4	Dichtung	Gasket	1
M21MGA-12	Dichtung Steuerkettendeckel	Gasket timing chain cover	1
M23MGA-12	Simmerring Steuerdeckel	Oil seal timing chain cover	1
M24MGA-12	Dichtung Motorplatte vorne	Gasket engine mounting plate front	1
M25MGA-12	Ölablaßschraube	Oil drain plug	1
M29MGA-12	Anschluß Motorblock Öldruckinstrument	Union oil pressure gauge pipe	1
M30MGA-12	Dichtring	Washer oil/water drain plug	1
M31BMGB-01	Konkavscheibe Motor-Seitendeckel	Washer cup cover	2
M32MGB-02	Motor-Seitendeckel mit Ölabscheider 18GB-18GG23727 (64-69)	Engine side cover with oil breather 18GB-18GG23727 (64-69)	1
M32AMGB-02	Motor-Seitendeckel mit Ölabscheider ab 18GG23728 (ab 69)	Engine side cover with oil breather from 18GG23728 (from 69)	1
M32BMGB-02	Gummi-Ring Motorseitendeckel	Washer rubber engine side cover	2
M42MGB-12	Motor-Seitendeckel hinten ab 69	Blanking plate petrol pump	1
M45MGA-12	Verschlußplatte Benzinpumpe	Engine side cover rear from 69	1
M45MGB	Sicherungsblech Simmerring hinten 1965-76	retainer, oil seal 1965-76	1
M45MGB/RB	Sicherungsblech Simmerring hinten 18V ab 1976	retainer, oil seal from 1976	1
M36MGA-11	Dichtung Filter/Ölpumpe	Gasket strainer to pump	1
M37MGA-11	Sieb Ölpumpe	Strainer oil pump	1
M39AMGB-02	Stopfen Motorplatte hinten	Plug engine mounting plate rear	1
M40MGB-02	Dichtung Motorplatte oben	Gasket engine mounting plate upper	1
M41MGA-12	Dichtung Motorseite Kork	Gasket engine side cover (cork)	1
M41MGB-02	Sicherungsblech	Lock tab	1
M42MGA-12	Motor Seitendeckel hinten 18GB-18GG23727 (64-69)	Engine side cover rear 18GB-18GG23727 (64-69)	2
M42MGB-02	Sicherungsblech	Lock tab	1
M43MGB-02	Sicherungsblech	Lock tab	2
M44MGB-02	Simmerring Kurbelwelle ab 18GB hinten	Crankshaft oil seal from 18GB rear	1
M50MGA-11	Ölfiltereinsatz	Oil filter paper	1
M65MGB-01	Dichtung Motorplatte hinten	Gasket engine mounting plate/block	1
M74SPT	Dichtring Ölablaßschraube	Sealing washer oil/water drain plug	1
M75MGB-01	Motordicht-Satz unten MGB 5-Lager	Engine gasket set bottom MGB 5-bearing	1
M83MGB-02	Ölpumpe MGB 5-Fach gelagerter Motor	Oil pump MGB 5-bearing	1
M84MGB-02	Dichtung Ölpumpe/Gehäuse	Gasket oil pump/crankcase	1
M87MGB-02	Ölwannen-Dichtung MGB 5-Lager	Oil sump gasket MGB 5 bearing	1
M100MGB	Aluminium Ölwanne	Aluminium oil sump	1
MÖ	Motoröl 20W50, pro Liter	Motor oil 20W50, per liter	A/R
MÖRACE	Motoröl 20W50 Racing für Sportzwecke, pro Liter	Motor oil 20W50 Racing for competition use, per liter	A/R
MD17SPT	Dauerplast. Universaldichtung "Marston" 80 ml	Universal jointing compound "Marston" 80 ml	A/R
MD17aSPT	Hochwertige Silikondichtmasse - schwarz "Hylosil" 200 ml	Silicone sealant - black "Hylosil" 200 ml	A/R

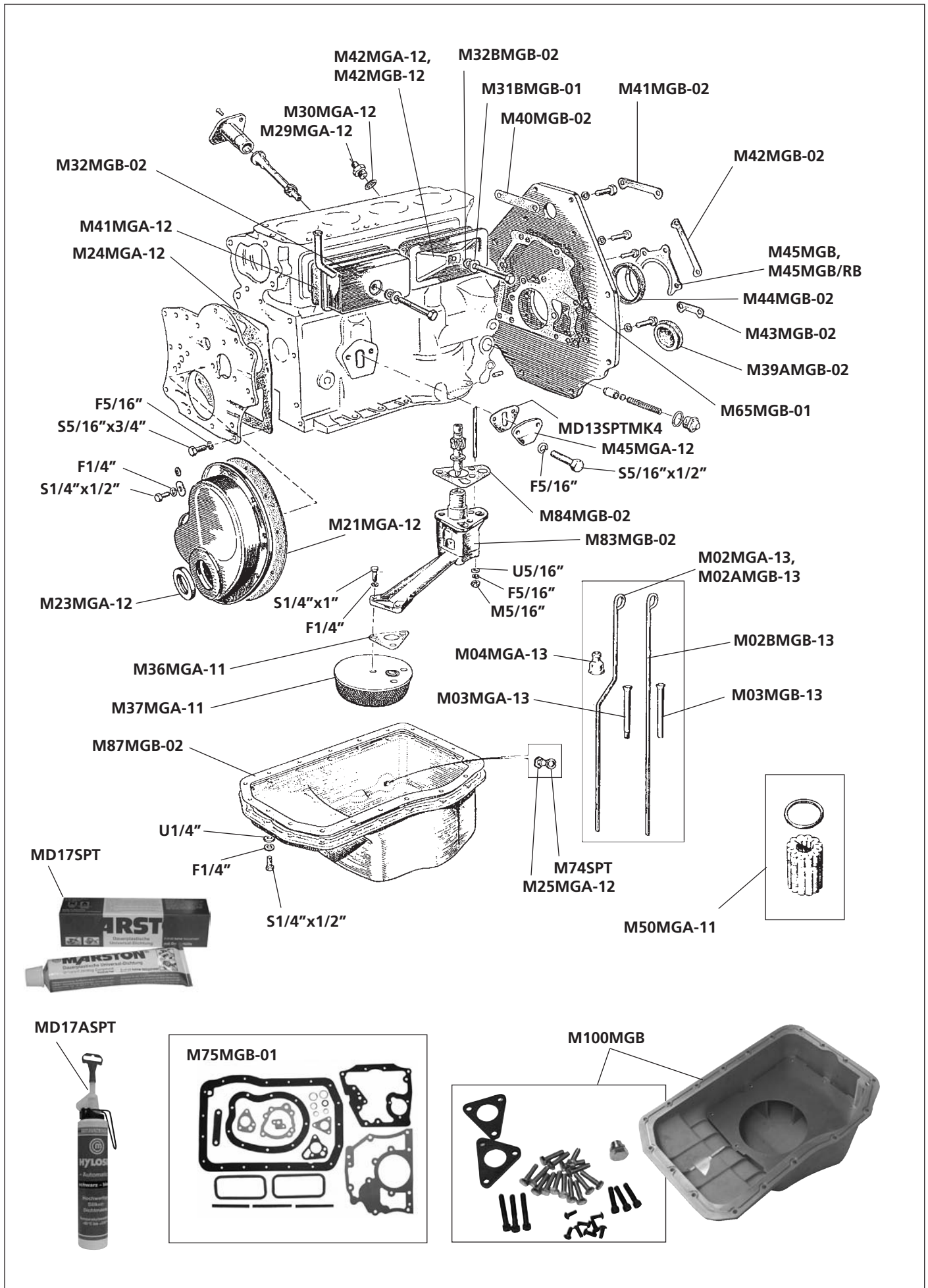

No.	Bezeichnung	Description	Anzahl/Qty.
ZK1MGB/18G	AT-Zylinderkopf 18GB,18GD,18GG	Exch. cylinder head 18GB,18GD,18GG	1
ZK1MGB/18V	AT-Zylinderkopf 18V	Exch. cylinder head 18V	1
ZK1MGB/18V-N	Zylinderkopf NEU 18V	Cylinder head NEW 18V	1
ZK21MGA-15	Thermostatgehäuse bis 18GB (bis 67)	Thermostat housing to 18GB (up to 67)	1
K02MGB-13	Thermostatgehäuse ab 18GB (bis 76)	Thermostat housing from 18GB (up to 76)	1
K03MGB-13	Thermostatgehäuse ab 76	Thermostat housing from 76	1
K4SPT	Thermostat 74°C	Thermostat 74°C	1
K4ASPT	Thermostat 82°C	Thermostat 82°C	1
ZK01MGA-17	Einstellschraube	Collar valve spring lower 18V	8
ZK4TR4	Ventilsitzring Einlass	insert seat inlet valve	4
ZK5TR4	Ventilsitzring Auslass	insert seat exhaust valve	4
ZK05MGB-02	Ventildeckel-Stehbolzen ab 18GG (ab 67)	Rocker cover retaining bolt from 18GG (from 67)	2
ZK05MGA-09	Feder zwischen Kipphebel	Spring rocker spacing	3
ZK05MGB-01	Satz Ventilfebern 18GB-18V (64-71)	Valve springs set 18GB-18V (64-71)	1
ZK05AMGB-01	Satz Ventilfebern (einfach) 18V ab 71	Valve springs set 18V from 71	1
ZK05MGA-08	Stehbolzen kurz	Manifold stud short	4
ZK06MGA-08	Stehbolzen lang	Manifold stud long	2
K05MGB-13	Stopfen	Plug	2
K06MGB-13	Dichtung	Seal	2
ZK06MGB-02	Öleinfülldeckel	Oil filler cap	1
ZK06MGA-09	Haltefuss Kipphebelwelle	Bracket rocker shaft	1
ZK07MGA-09	Haltefuss Kipphebelwelle flach	Bracket rocker shaft plain	3
ZK07MGA-08	Ventildeckel Aluminium poliert	Rocker cover alloy polished	1
ZK09MGA-08	Ventildeckel-Dichtung	Rocker cover gasket	1
ZK08MGB-02	Klemmkeil Ventil	Valve cotter	8
ZK08MGA-09	Schraube Kipphebelwelle	Screw locating rocker shaft	1
ZK09MGA-09	Haltescheibe	Plate locking	1
ZK10AMGB-02	Ventilschaftdichtung	Ring sealing valve stem	8
ZK11MGA-08	Ventildeckel-Mutter verchromt 18GB bis 67	Rocker cover retaining nut chromed 18GB up to 67	2
ZK11MGA-09	Klemmkeil Ventile 18GB-18GD (64-67)	Collet 18GB-18GD (64-67)	16
ZK11MGB-02	Ventilfeder innen	Valve spring inner	8
ZK12MGB-02	Ventilfeder aussen	Valve spring outer	8
ZK12MGA-09	Klammer Ventilkeil 18GB-18GD (64-67)	Circlip, collet	8
ZK12MGA-08	Scheibe Ventildeckelmutter	Washer rocker cover nut	2
ZK13MGA-09	O-Ring Ventilschaft	O-ring valve shaft	8
ZK14MGA-08	Scheibe Ventildeckelmutter	Washer rocker cover nut	2
ZK14MGA-09	Ventilfederkappe oben 18GB-18GD (64-67)	Collar, top 18GB-18GD (64-67)	8
ZK14MGB-09	Ventilfederkappe oben 18GD-18V (67-71)	Collar, top 18GD-18V (67-71)	8
ZK14AMGB-09	Ventilfederkappe oben 18V (ab 71)	Collar, top 18V (from 71)	8
ZK16MGA-08	Gummi-Dichtring Ventildeckel	Rubber washer rocker cover	2
ZK18MGA-09	Unterlage Ventilfeber 18GB-18V (bis 71)	Srew adjusting rocker	8
ZK18MGB-09	Unterlage Ventilfeber 18V	Collar valve spring lower 18GB-18V (up to 71)	8
ZK20MGB-02	Ausgleich-Scheibe Mittlerer Halter	Shim adjusting centre bracket	2
ZK20MGA-09	Einlassventil bis 18GD 0835 (39,7 mm)	Inlet valve (39.7 mm)	4
A21MGA-14	Scheibe Auspuffkrümmer	Manifold yoke	6
A25MGA-14	Mutter Auspuffkrümmer	Nut exhaust manifold	6
K22MGA-15	Thermostatdichtung	Gasket thermostat housing	1
ZK22MGA-09	Auslassventil bis 18GD 0835 (34,2 mm)	Exhaust valve up to 18GD 0835 (34.2 mm)	4
ZK23MGA-09	Ventilführung Einlass	Inlet valve guide	4
ZK24MGA-08	Stehbolzen Thermostatgehäuse	Stud thermostat housing	3
ZK24AMGB-02	Einlassventil 18GD + 18V (39,7 mm) ab 67	Inlet valve from 18GD + 18V (39.7mm) from 67	4
ZK24BMGB-02	Einlassventil 18GD + 18V (41,2 mm) ab 67	Inlet valve from 18GD + 18V (41.2 mm) from 67	4
ZK25AMGB-02	Auslassventil ab 18GD 0835 + 18V (34 mm) ab 67	Exhaust valve from 18GD 0835 + 18V (34 mm) from 67	4
ZK25MGA-09	Ventilführung Auslass	Valve guide exhaust	4
K25MGA-32	Dichtung	Gasket	1
M26MGB-01	Zylinderkopf-Dichtung	Cylinder head gasket	1
M26CMGB-02	Zylinderkopf-Dichtsatz	Cylinder head gasket set	1
ZK27MGA-09	Ventilführungen-Satz Bronze	Valve guides set bronze	1
ZK31MGA-08	Stehbolzen Kipphebelwelle lang	Stud rocker cover long	2
ZK32MGA-08	Stehbolzen Kipphebelwelle kurz	Stud rocker cover short	2
ZK33MGA-08	Kipphebelwelle	Rocker shaft	1

No.	Bezeichnung	Description	Anzahl/Qty.
K34MGB-13	Wassertemperaturgeber	Thermal transmitter	1
ZK36MGA-08	Kipphebel	Rocker arm	8
ZK37MGA-08	Kipphebelbuchse	Rocker bush	8
ZK38MGA-08	Einlass/Auslassdichtung	Gasket inlet/exhaust	1
ZK85SPT	Mutter UNF 5/16 x 3/16" 18GB bis 67	Nut UNF 5/16 x 3/16" 18GB up to 67	8
ZK90MGB-02	Ventildeckel	Rocker cover	1

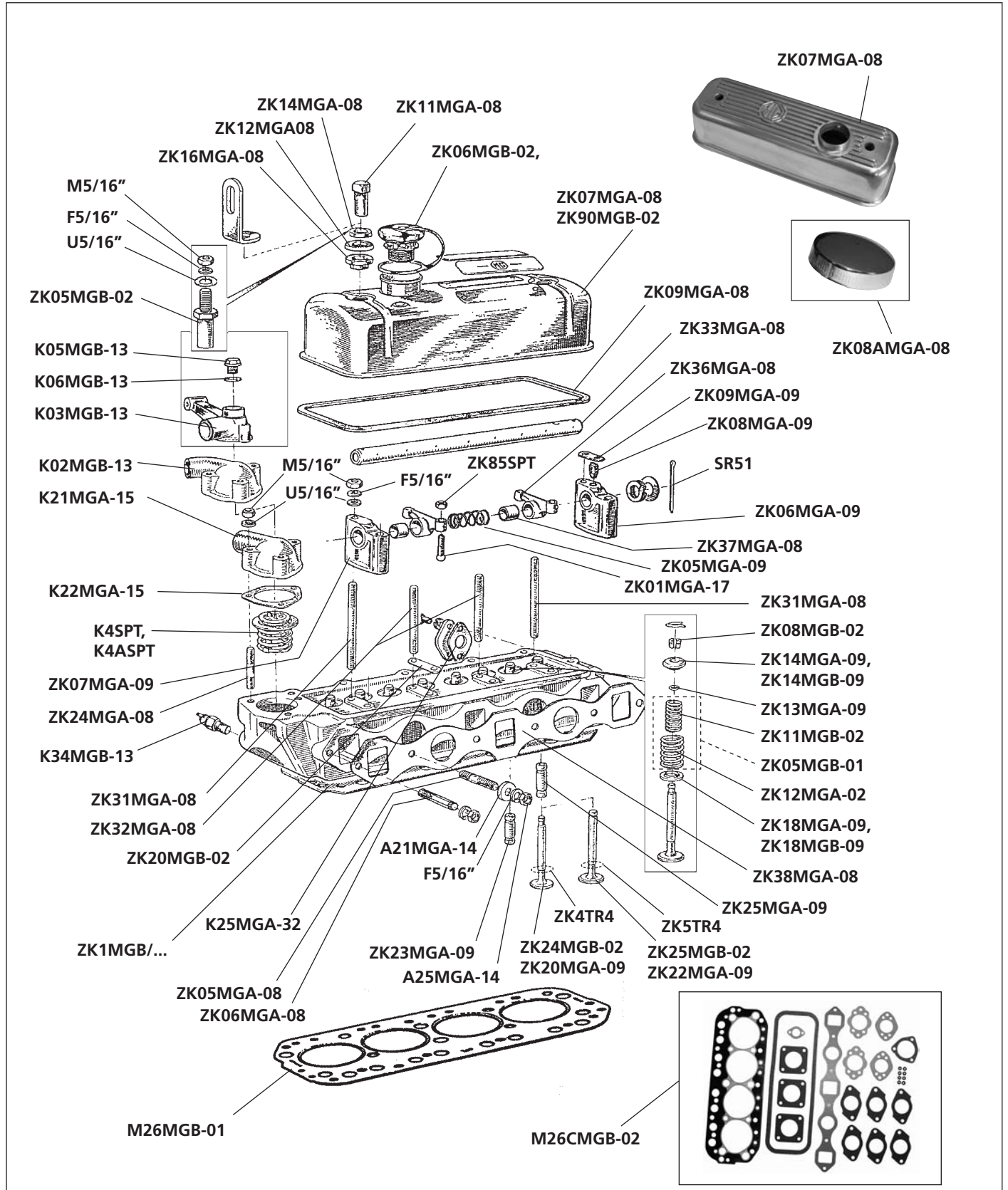

No.	Bezeichnung	Description	Anzahl/Qty.
K06MGB-05	Anschlussstück Ölkühler-Schlauch	Adaptor oil cooler hose	2
K07MGB-05	Anschluß Ölkühlerleitung an Motorblock	Fixation oil cooler hose to engine	2
K08MGB-05	Gummi-Durchführung Ölkühler-Schlauch	Rubber grommet oil cooler hose	2
K14MGA	Ölkühler-Schlauch stahlummantelt bis 18GB 3-Synchro (bis 67)	Oil cooler hose steel reinforced to 18GB 3-synchro (up to 67)	2
K17SPT	Ölkühler 13-reihig	Oil cooler radiator 13 row	1
K23MGA	Kühlerschlauch mit Anschlussgewinde für ThermoSchalter	Water hose with thread	1
M25MGA-13	Adapter für Ölfilterpatrone K33TR bis 69	Adaptor for oil filter no. K33TR up to 69	1
K28AMGB	Ölkühler-Schlauch Kühler zu Filter, stahlummantelt 4-Synchro (Chromstoßstangenmodell) 67-74	Oil cooler hose - cooler to filter steel reinforced 4-synchro (Chrome bumper model) 67-74	1
K28BMGB	Ölkühler-Schlauch Kühler zu Motorblock, stahlummantelt 4-Synchro (Chromstangenmodell) 67-74	Oil cooler hose - cooler to engine, steel reinforced 4-synchro (Chrome bumper model) 67-74	1
K29AMGB	Ölkühler-Schlauch Kühler zu Filter, stahlummantelt (Gummistoßstangenmodell) 74-76	Oil cooler hose - cooler to filter, steel reinforced (Rubber bumper model) 74-76	1
K29BMGB	Ölkühler-Schlauch Kühler zu Motorblock 74-76 und Kühler zu Filter, stahlummantelt ab 76 (Gummistoßstangenmodell)	Oil cooler hose - cooler to engine 74-76 + cooler to filter, steel reinforced from 76 (Rubber bumper model)	1
K29GT6	Schlauchthermostat	Thermostat oil cooler hose	1
K30MGB	Doppelhalter für Schläuche	Strap kit	3/2
K30TR	Ölkühler 16-reihig	Oil cooler radiator 16 row	1
M37MGA-12	Kupferscheibe	Copper washer	1
M50MG	Filterplatte 18G & 18GA (62-64)	Filter head 18G & 18GA Purolator (62-64)	1
M50AMG	O-Ring	O-ring	1
M51MG	Filterplatte 18G -18GB, Tecalamit Typ (62-67)	Filter head 18G -18GB Tecalamit Type (62-67)	2
M52MG	Adapter Ölfilter 18GD & 18GG stehender Ölfilter	Adaptor oil filter 18GD & 18GG inverted	1
M74VO	Kupferdichtring	Copper washer	1
M97MGB	Ölfilter 18GH - 18V Motoren	Oil filter 18GH - 18V engine	1

**Hinweis
Note:**

Wir empfehlen den oft serienmäßig verbauten
10-reihigen Ölkühler durch den 13-reihigen Ölkühler K17SPT
zu ersetzen!

Wir empfehlen ausschließlich die Verwendung von stahlummantelten
Ölkühlerschläuchen!

We recommend to replace the serial oil cooler
radiator 10 row with the radiator 13 row no. K17SPT

We also recommend to fit steel reinforced hoses!

16 Zusatzlüfter / Electric Fan

No.	Bezeichnung	Description	Anzahl/Qty.
K20SPT	Elektrolüfter	Electric fan	1
K20ASPT	Ventilatorhalter universal (4x erforderlich)	Fan fitting kit, universal (necessary 4x)	4
K21SPT	Thermostat zu K22MGA	Thermostat for K22MGA	1
K22MGA	Wasserrohr mit Anschlußgewinde	Water hose with thread	1
K22SPT	Wasserrohr mit Anschlußgewinde ab 71	Water hose with thread from 71	1
K23MGA	Kühlerschlauch mit Anschlussgewinde für ThermoSchalter	Water hose with thread	1
K200MGA	Elektrolüfter-Kit bestehend aus: K20SPT, 4x K20ASPT, K21SPT, K22MGA - passend für alle MGA/MGB Modelle	Electric fan kit contains: K20SPT, 4x K20ASPT, K21SPT, K22MGA - suitable for all MGA/MGB models	1

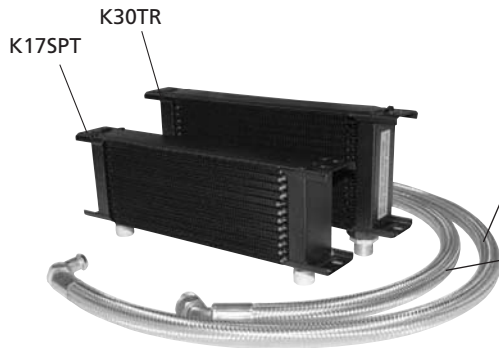

K28BMGB,
K29BMGB
K14MGA

K28AMGB,
K29AMGB,
K14MGA

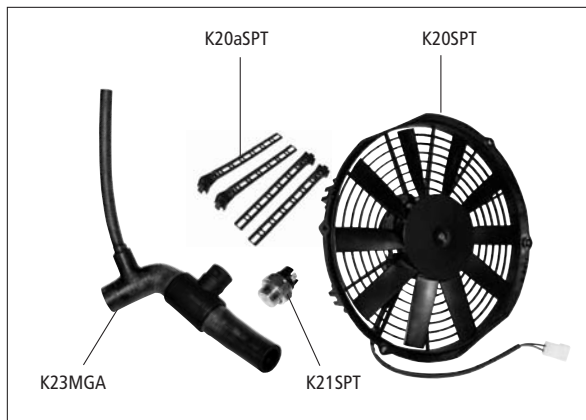
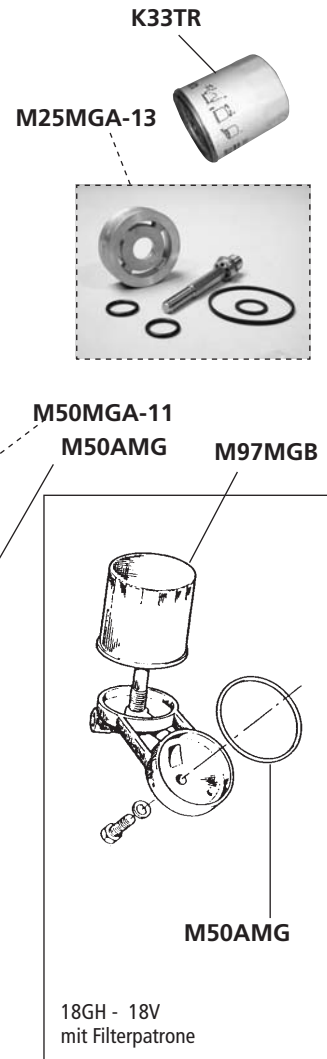
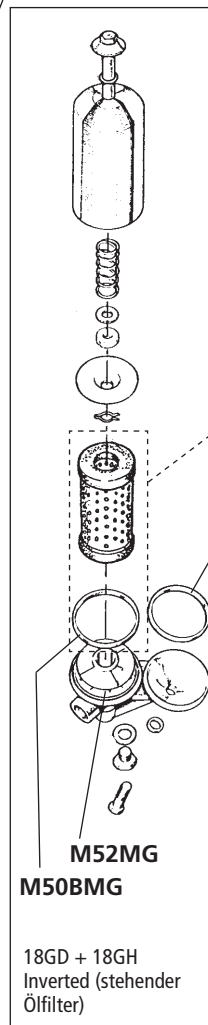
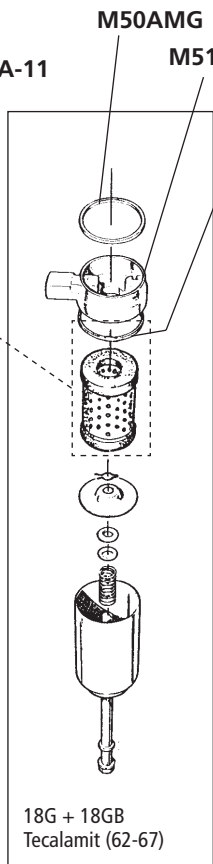
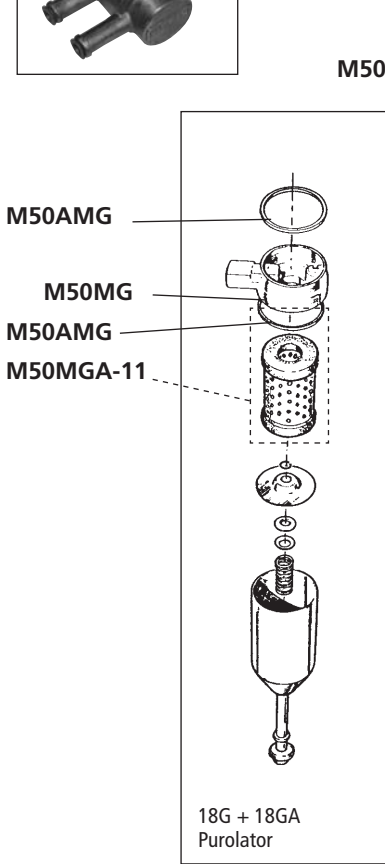
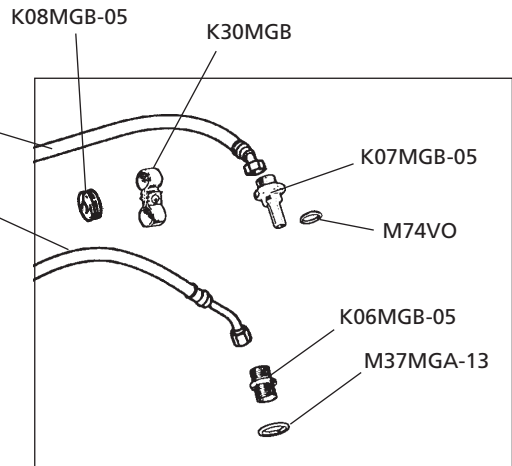

K200MGA
(für alle MGA/MGB Modelle passend /
suitable for all MGA/MGB models)

No.	Bezeichnung	Description	Anzahl/Qty.
M03MGB-03	Motoraufhängung vorne ab 74 Gummistoßst.modell	Engine mounting front from 74 Rubber bumper model	2
M03AMGB-03	Halter Motoraufhängung rechts	Bracket engine mounting rh	1
M03BMGB-03	Halter Motoraufhängung links	Bracket engine mounting lh	1
M04MGB-03	Getriebeaufhängungsgummi hinten	Rubber gearbox mounting rear	2
M06MGB-03	Gummi-Puffer	Buffer rubber	2
M05MGB-03	Buchse Schubstrebe	Bush steady rod	2
M07MGB-03	Gummi-Lager Getriebehals hinten - nur GT 65-67/3-Synchro	Rubber gearbox mounting rear - only GT 65-67/3-synchro	2
M08MGA-13	Motoraufhängung vorne rechts 62-74 Chromstoßst.modell	Engine mounting front rh 62-74 Chrome bumper model	1
M08MGB-03	Gummi-Buchse Aufhängung hinten	Rubber bush steady rod	2
M08MGA-HD	Hinterer Motorgummi RH, Chromstoßst.modell	rear engine mounting RH, chrome bumper model	1
M09MGB-03	Distanz-Hülse Getriebestabilisator	Spacing tube stay rod gearbox	1
SR9	Senkopschraube Halteblech links 5/16"x1"	Countersunk screw bracket engine mounting lh 5/16"x1"	2
M10MGA-13	Motoraufhängung vorne links 62-74 Chromstoßst.modell	Engine mounting front lh 62-74 Chrome bumper model	1
M10MGB-03	Haltestrebe Getriebe	Stay rod gearbox	1
M10MGA-HD	Hinterer Motorgummi LH, Chromstoßst.modell	rear engine mounting LH, chrome bumper model	1
M11MGB-03	Stift Getriebeaufhängung hinten	Pin rear gearbox mounting	1
M11MGA-13	Halteblech Motoraufhängung rechts	Bracket engine mounting rh	1
M12MGA-13	Halteblech Motoraufhängung links	Bracket engine mounting lh	1

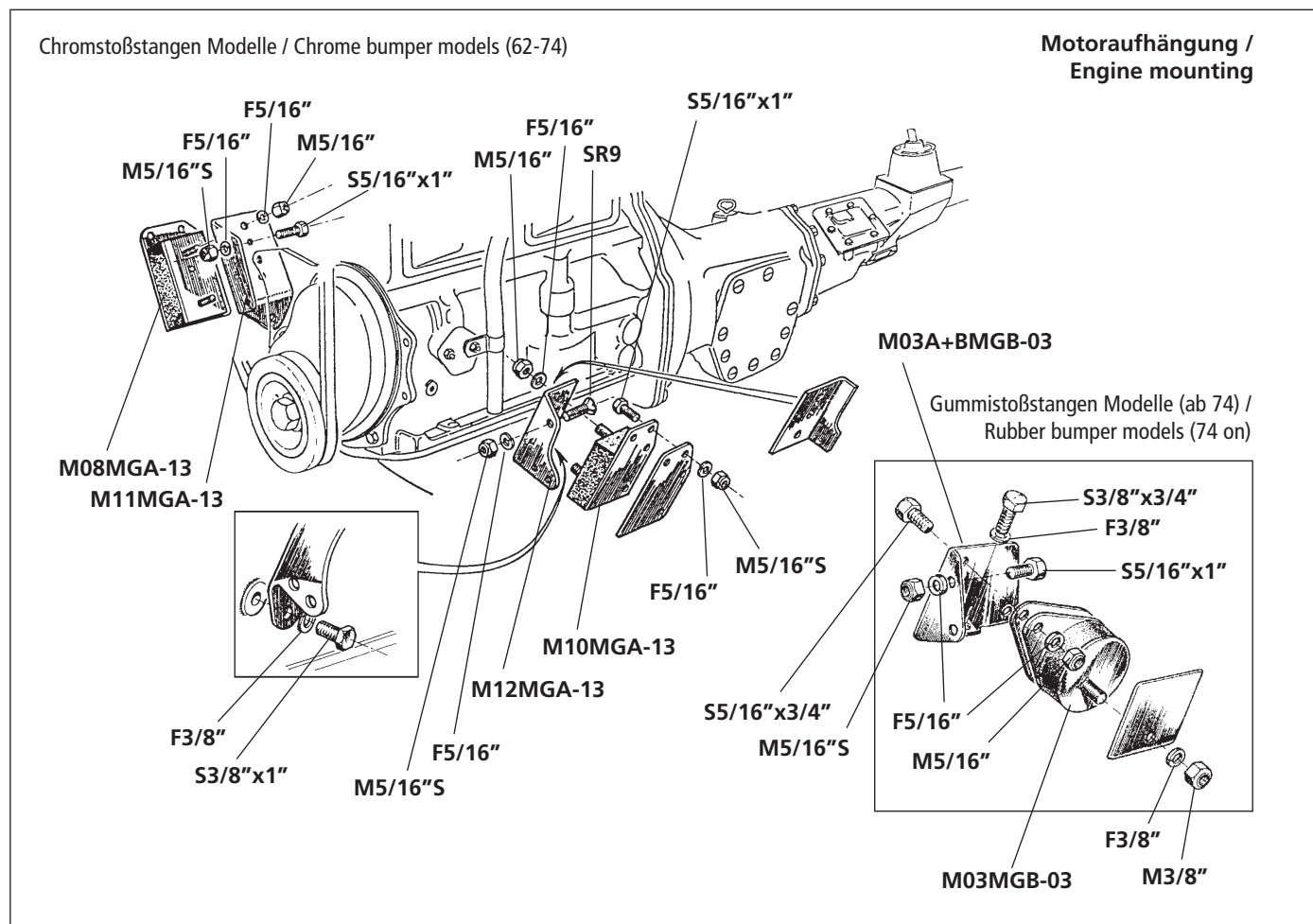

Getriebeaufhängung / Gearbox mounting

Type 1 (62-67) 3-Synchro Roadster

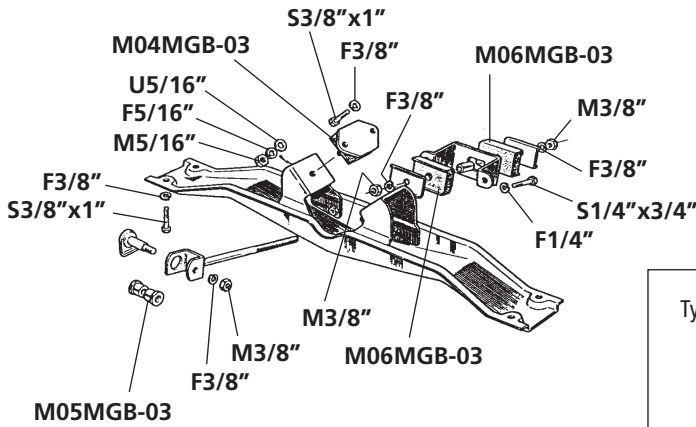

Type 2 (65-67) 3-Synchro GT

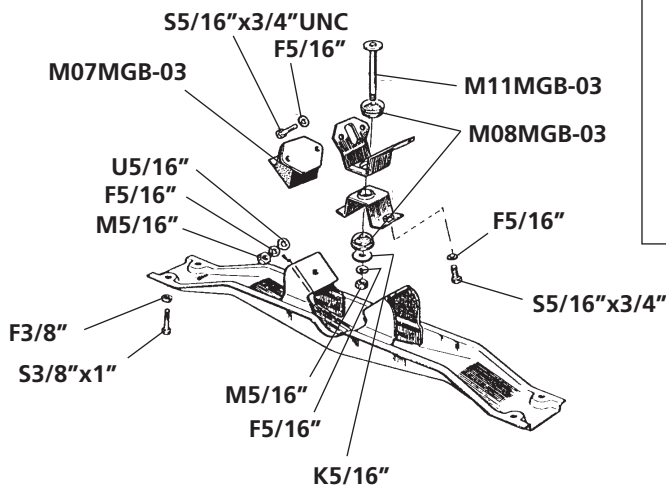

Type 3 (67-74) 4-Synchro Modelle

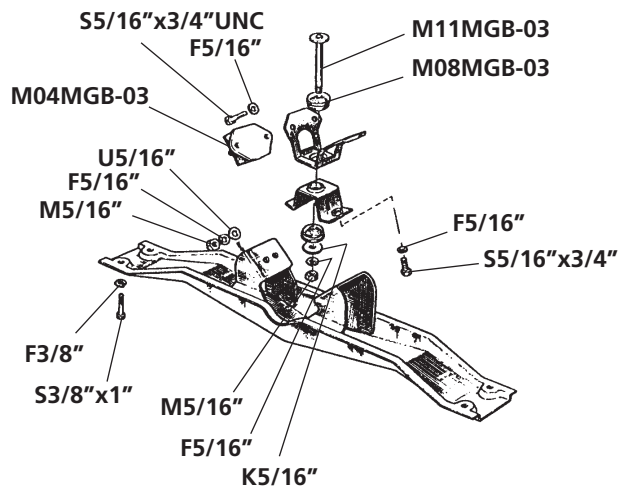

Type 4 (ab 74 / 74 on)

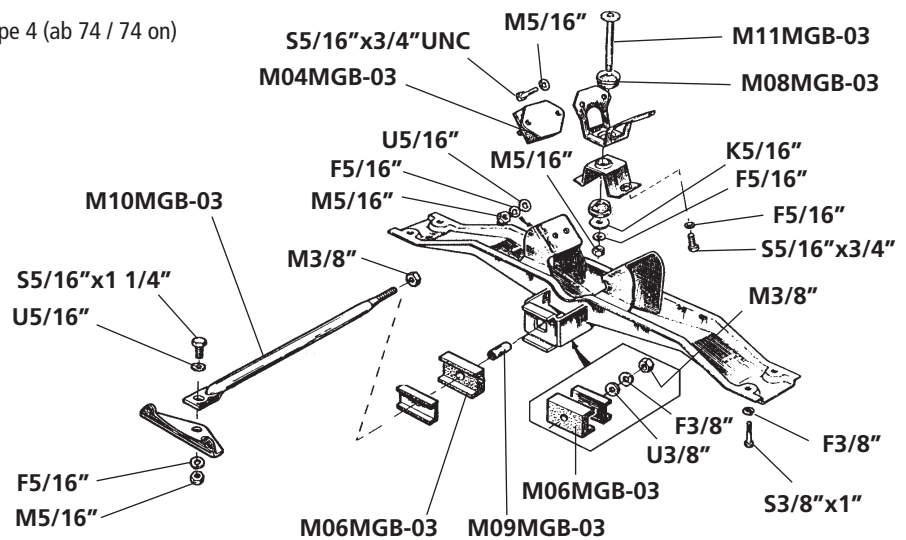

No.	Bezeichnung	Description	Anzahl/Qty.
Auspuffanlage Standard		Standard exhaust system	
A1MGB	Hosenrohr	Front pipe	1
A2MGB	Vorschalldämpfer	Front silencer	1
A3MGB	Verbindungsrohr (Chromstoßstangen Modell)	Link pipe (chrome bumper model)	1
A3AMGB	Verbindungsrohr (Gummistoßstangen Modell)	Link pipe (rubber bumper model)	1
A4MGB	Endschalldämpfer (Chromstoßstangen Modell)	Rear silencer (chrome bumper model)	1
A4AMGB	Endschalldämpfer (Gummistoßstangen Modell)	Rear silencer (rubber bumper model)	1
Sportauspuffanlage		Sport exhaust system	
A10MGB	Fächerkrümmer	Manifold	1
A10AMGB	Hosenrohr (bei Verwendung des Original Krümmers)	Front pipe (when original manifold is fitted)	1
A11MGB	Verbindungsrohr	Link pipe	1
A12MGB	Endschalldämpfer (Chromstoßstangen Modell)	Rear silencer (chrome bumper model)	1
A12AMGB	Endschalldämpfer (Gummistoßstangen Modell)	Rear silencer (rubber bumper model)	1
Befestigungsmaterial Chromstoßstangen-Modell (62-75)		Fittings Chrome bumper model (62-75)	
A07MGB-14	Auspuffkrümmer-Dichtung	Exhaust manifold gasket	2
A08MGB-14	Halter Auspuff an Getriebe 3-Synchro	Bracket exhaust gearbox 3-synchro	1
A08AMGB-14	Halter Auspuff an Getriebe 4-Synchro	Bracket exhaust gearbox 4-synchro	1
A10MGB-14	Auspuffschelle	Exhaust pipe clip	A/R
A16MGB-14	Auspuffaufhängung hinten bis GHN(D)4-167815	Exhaust mounting rear up to GHN(D)4-16781	1
A18MGB-14	Auspuffaufhängung-Halter bis GHN(D)4-167815	Exhaust mounting bracket up to GHN(D)4-167815	1
A19MGB-14	Haltebügel Auspuffaufhängung hinten	Bracket exhaust mounting rear	1
A20MGB-14	Klammer Auspuffaufhängung	Clip exhaust suttle	2
A21MGB-14	Auspuffaufhängung-Gummi hinten	Exhaust mounting rubber rear	2
A38MGA-14	Auspuff-Rohraufhängung mitte	Exhaust pipe mounting intermediate	1
A54MGA-14	Gehäuse Auspuffaufhängung mitte	Housing exhaust mounting intermediate	1
A56MGA-14	Buchse Auspuffaufhängung mitte	Bush exhaust mounting intermediate	2
A57MGA-14	Haltestreifen Auspuff an Getriebe	Exhaust mounting strap gearbox	1
Befestigungsmaterial Gummistoßstangen-Modell (ab 75)		Fittings Rubber bumper model (75 on)	
A07MGB-14	Auspuffkrümmer-Dichtung	Exhaust manifold gasket	2
A10MGB-14	Auspuffschelle	Exhaust pipe clip	A/R
A19MGB-14	Haltebügel Auspuffaufhängung hinten	Bracket exhaust mounting rear	1
A20MGB-14	Klammer Auspuffaufhängung	Clip exhaust suttle	2
A21MGB-14	Auspuffaufhängung-Gummi hinten	Exhaust mounting rubber rear	2
A25MGB-14	Halter Auspuff an Getriebe 4-Synchro	Bracket exhaust gearbox 4-synchro	1
A33MGB-14	Auspuffaufhängung Halter an Karosserie	Exhaust mounting bracket	1
A37MGB-14	Auspuff-Isolierscheibe hinten	Exhaust insulating washer rear	4
A38MGA-14	Auspuff-Rohraufhängung mitte	Exhaust pipe mounting intermediate	1
A38MGB-14	By-Pass-Rohr als Ersatz für Katalysator -o.Abb	Exhaust test pipe replace catalyst -w/o illust	1
A39MGB-14	Katalysator ab Bj. 77 -o. Abb.	Catalyst from 1977 -w/o illust	1
A40MGB-14	Dichtung Auspuffkrümmer/Katalysator -o. Abb.	Gasket exhaust manifold/catalyst -w/o illust	1
A54MGA-14	Gehäuse Auspuffaufhängung mitte	Housing exhaust mounting intermediate	1
A56MGA-14	Buchse Auspuffaufhängung mitte	Bush exhaust mounting intermediate	2
A57MGA-14	Haltestreifen Auspuff an Getriebe	Exhaust mounting strap gearbox	1
Universalschellen		Universal Brackets	
A514	Bügelschelle verzinkt Ø 48 mm	Bracket galvanised Ø 48 mm	A/R
A515	Bügelschelle verzinkt Ø 51 mm	Bracket galvanised Ø 51 mm	A/R
A516	Bügelschelle verzinkt Ø 54 mm	Bracket galvanised Ø 54 mm	A/R
SCH47	Edelstahlschelle Ø 48 mm	Bracket stainl. Ø 48 mm	A/R
SCH51	Edelstahlschelle Ø 51 mm	Bracket stainl. Ø 51 mm	A/R
SCH55	Edelstahlschelle Ø 54 mm	Bracket stainl. Ø 54 mm	A/R

Auspuffanlage Standard / Standard exhaust system

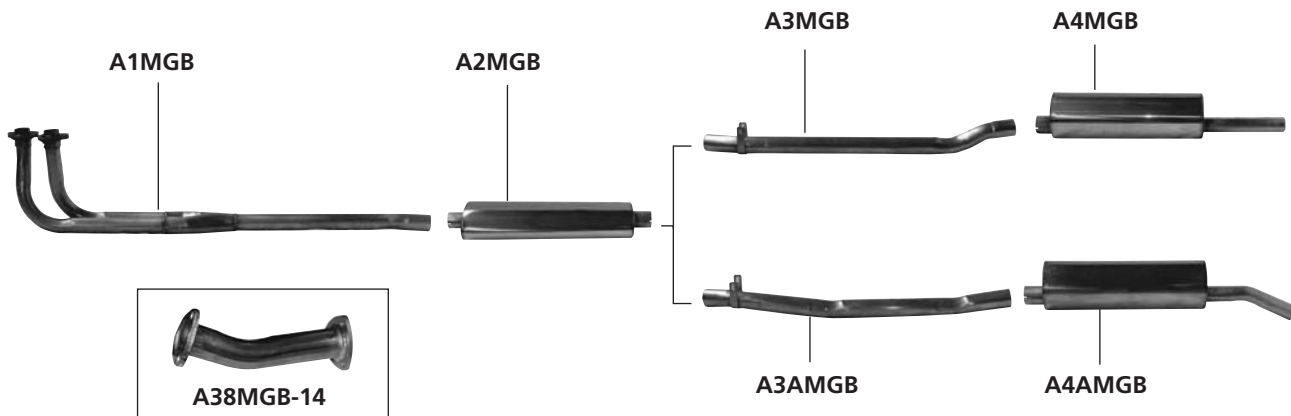

Sportauspuffanlage / Sport exhaust system

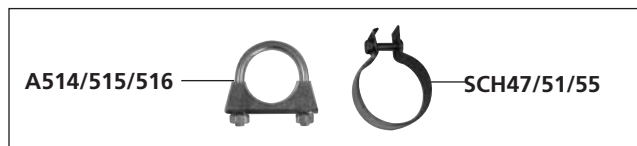
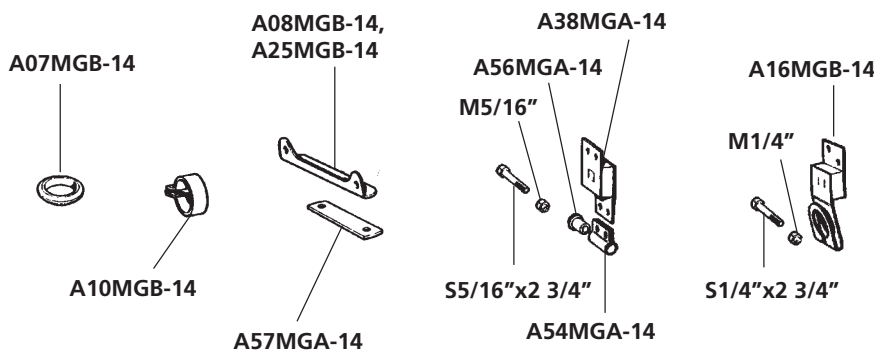
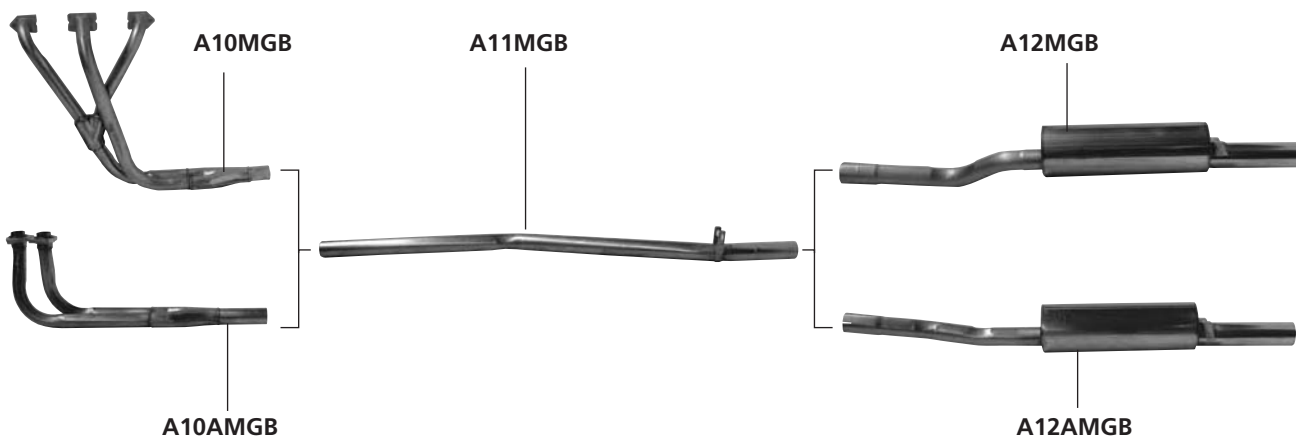

Halter Chromstoßstangen-Modell / Bracket Chrome bumper model

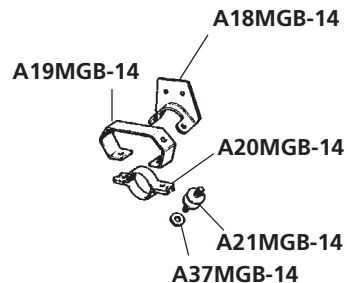

Halter Gummistoßstangen-Modell / Bracket Rubber bumper model

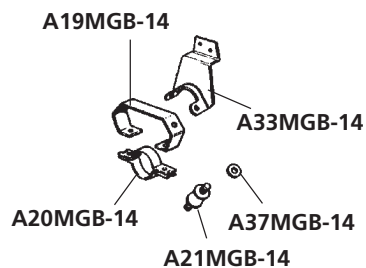

No.	Bezeichnung	Description	Anzahl/Qty.
ZK05MGA-08	Krümmer Stehbolzen kurz	Manifold stud short	2
ZK06MGA-08	Krümmer Stehbolzen lang	Manifold stud long	4
K8ASPT	Schlauch Entlüftungsventil 1/2"	Hose breather valve 1/2"	1
K9SPT	Schlauchschelle 12-22 mm	Hose clip 12-22 mm	A/R
V16MGB-04	Emissions-Kontrollventil	Emission control valve	1
M75SPT	Membrane Kurbelgehäuse-Entlüftung	Diaphragm breather valve	1
V18MGB-04	Entlüftungsschlauch/Y-Teil	Breather hose engine/y-piece	1
V19MGB-04	Schlauch Y-Teil/Vergaser	Hose y-piece to front carburettor	1
V20MGB-04	Schlauch Y-Teil/Vergaser hinten	Hose y-piece to rear carburettor	1
A21MGA-14	Scheibe Auspuff-Krümmer	Yoke exhaust manifold	4
V23BMGB-04	Adapter Ventil Druckausgleich	Adaptor breather valve	1
V23CMGB-04	Stehbolzen UNF/UNC 5/16 x 2 1/2"	Stud UNF/UNC 5/16 x 2 1/2"	A/R
A25MGA-14	Auspuff-Krümmer-Mutter 5/16 UNF	Exhaust manifold nut 5/16 UNF	6
A25MGB-04	Auspuff-Krümmer MGB 62-70	Exhaust manifold MGB 62-70	1
A25AMGB-04	Auspuff-Krümmer MGB ab 70	Exhaust manifold MGB 70 on	1
ZK38MGA-08	Ein-/Auslassdichtung	Gasket exhaust manifold	1
A29MGB-04	Stehbolzen UNF/UNC 5/16 x 1 5/8"	Stud UNF/UNC 5/16 x 1 5/8"	6
V30MGB-04	Dichtung Luftfilterelement	Gasket air filter element	2
V32MGB-04	Vergaser-Distanzstück	Carburettor distance piece	2
V34MGB-04	Luftfilter-Element MGB	Air filter element MGB	2
V35MGB-04	Gummi-Verbindung Luftfilter	Rubber connection air filters	1
V36MGB-04	Bolzen UNF 5/16 x 5"	Bolt UNF 5/16 x 5"	6
V36AMGB-04	Bolzen UNC 5/16 x 4 1/2"	Bolt UNC 5/16 x 4 1/2"	6
V37MGB-04	Halterung Luftfilter vorne	Bracket air filter front	1
V38MGB-04	Halterung Luftfilter hinten	Bracket air filter rear	1
V40MGB-04	Hitzeschild MGB bis 75, HS-Vergaser	Heatshield MGB up to 75 HS carburettor	1
V41MGB-04	Hitzeschild MGB ab 75, HIF4-Vergaser	Heatshield MGB from 75 HIF4 carburettor	1
V72HS4	Ansaugstutzen-Dichtung	Gasket inlet manifold	6
V73HS4	Dichtung Luftfilter	Gasket air filter	2
V75KNMGB	Filtereinheit für 2 Vergaser	Air filter unit for 2 carburettors	1
V75KNHS4	K&N Filter einzeln *)	Single piece K&N air filter *)	2
V75AHS4	Chromluftfilter für HS4-Vergaser *)	Chrome air filter for carburettor HS4 *)	2
V76AMGB	Y-Teil Gehäuseentlüftung	Y-piece breather	1
ZK85SPT	Mutter	Nut	6

*) Montage an Vergaser ohne originale Filterplatte

*) To be build on carburettor no original filter plate fitted

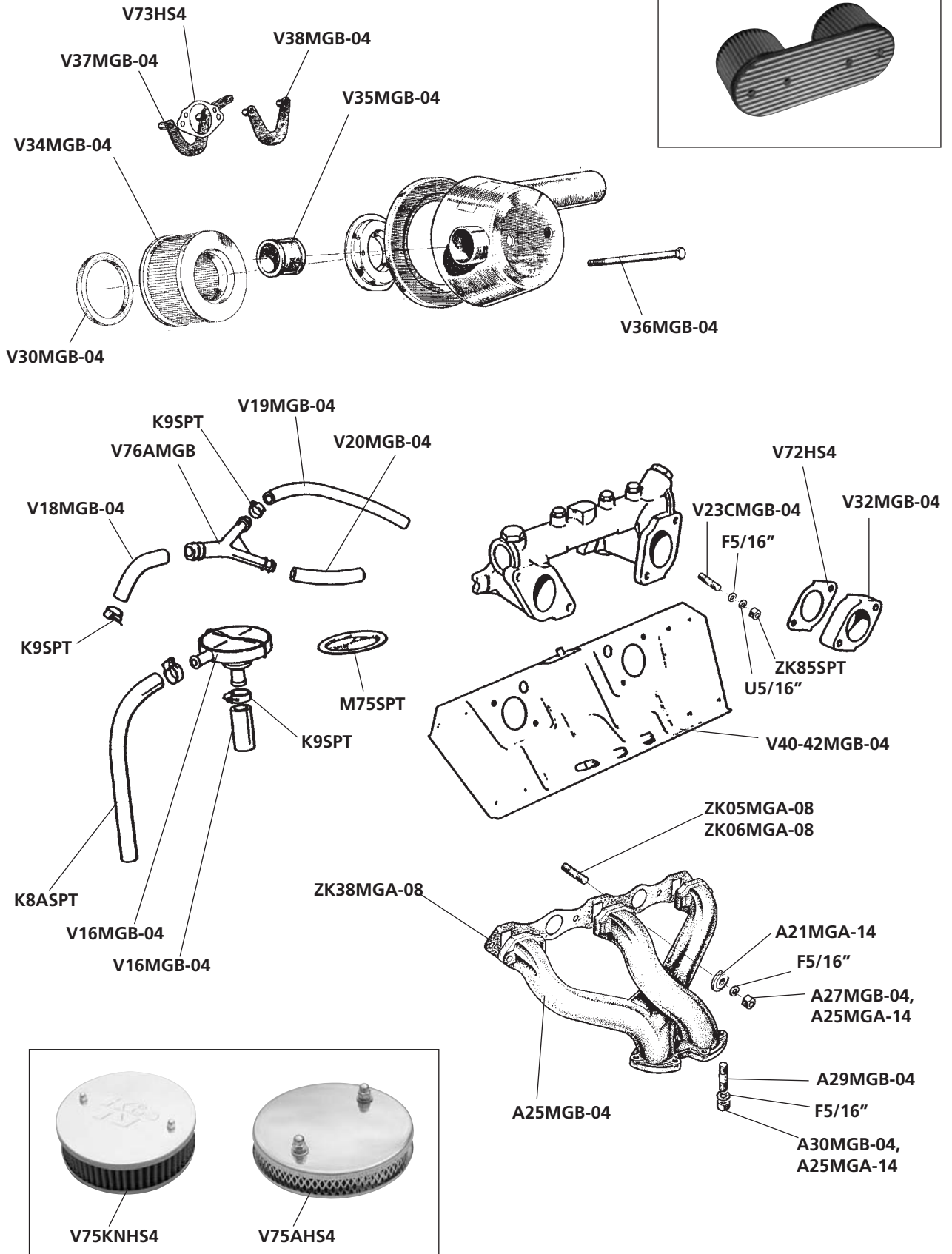

HS4 (1962-1973)

HS4 (1962-1973)

No.	Bezeichnung	Description	Anzahl/Qty.
V01MGBHS4	AT-Vergaser Satz HS4 MGB *)	Carburettor kit exchange HS4 MGB *)	1
V1HS	Schraube	Screw	6
V03MGB-04	Düsenstock HS4 MGB vorne (zum Kühler)	Jet HS4 MGB from 72 front (green)	1
V04MGB-04	Düsenstock HS4 MGB hinten (zur Spritzwand)	Jet HS4 MGB from 72 rear (pink)	1
V5TRHS6	Schraube Drosselklappe	Screw disc retaining, throttle	4
V5HS	Dichtung Schwimmerkammer	Gasket float chamber	2
V6HS	Schwimmernadelventil	Needle valve and seat kit	2
V9HS	Vergaser-Schwimmer	Carburettor float	2
V10TR	Madenschraube Düsennadel	Screw needle locking	2
V12HS4	Führung Vergaser Nadelhalterung für gefederte Nadeln	Guide carburettor needle (for needles with spring)	2
V13HS4	Feder Vergaser-Nadel	Carburettor needle spring	2
V16HS	Lager-Satz Düsenstock	Bearing kit jet	2
V22HS-MGB	Gummi-Distanzteil Vergaser/Schwimmer HS4 hinten	Rubber grommet carburettor HS4 rear	1
V22AHS-MGB	Gummi-Distanzteil vorne	Rubber grommet front	1
V25HS4	Vergaser-Nadel - bitte Nadelbezeichnung angeben	Carburettor needle - please refer type/dimension	2
V29HS	Vergaserdämpfer	Carburettor damper	2
V30TRH6	Vergaser-Kolben-Feder rot	Carburettor piston spring red	2
V38ATR	Buchse Drosselwelle 7,938 mm	Bush carburettor spindle .313"	4
V40HS4	Drosselklappe	Disc, throttle	2
V41HS4	Drosselklappenwelle	Throttle spindle	2
V73HS4	Luftfilterdichtung	Gasket air filter	2
V78SPT	Benzinschlauch Ø 8 mm / pro Meter	Fuel hose Ø 8 mm, per meter	A/R
V79SPT	T-Stück für V78SPT	T-piece to no. V78SPT	A/R
V80HS4	Vergaser-Papierdichtsatz HS4 (für 1 Vergaser)	Carburettor gasket pack HS4 (for 1 carburettor)	2
V81HS-MGB	Vergaser-Reparatursatz Kit HS4 (für 2 Vergaser) **)	Carburettor service-kit HS4 (for 2 carburettors) **)	2
WZ16MGA-53	Einstellschlüssel Vergaser-Gemisch	Adjusting tool mirror	A/R
WZ75	Vergaser-Synchro-Tester	Carburettor synchronizer	A/R
SU-VÖ	SU-Vergaseröl, 150 ml	Oil, SU carb. 150 ml	A/R

**Hinweis
Note:**

*) Durch die Vielzahl der verbauten Vergaser ist nur die Überholung Ihres vorhandenen eigenen Vergasers möglich. (Bearbeitungszeit ca. 4-6 Wochen)

*) Please note: Due to multiple variations of carburettors fitted on MGB models we can only offer to rebuild your existing carburettor. (Delivery time ca. 4-6 weeks)

***) Vergaserreparatursatz (2 Vergaser) = 2x Düsenstock, 2x Schwimmernadelventil, 2x Dichtsatz

***) Carburettor service kit (2 carburettors) = 2x jet, 2x needle valve and seat kit, 2x gasket pack

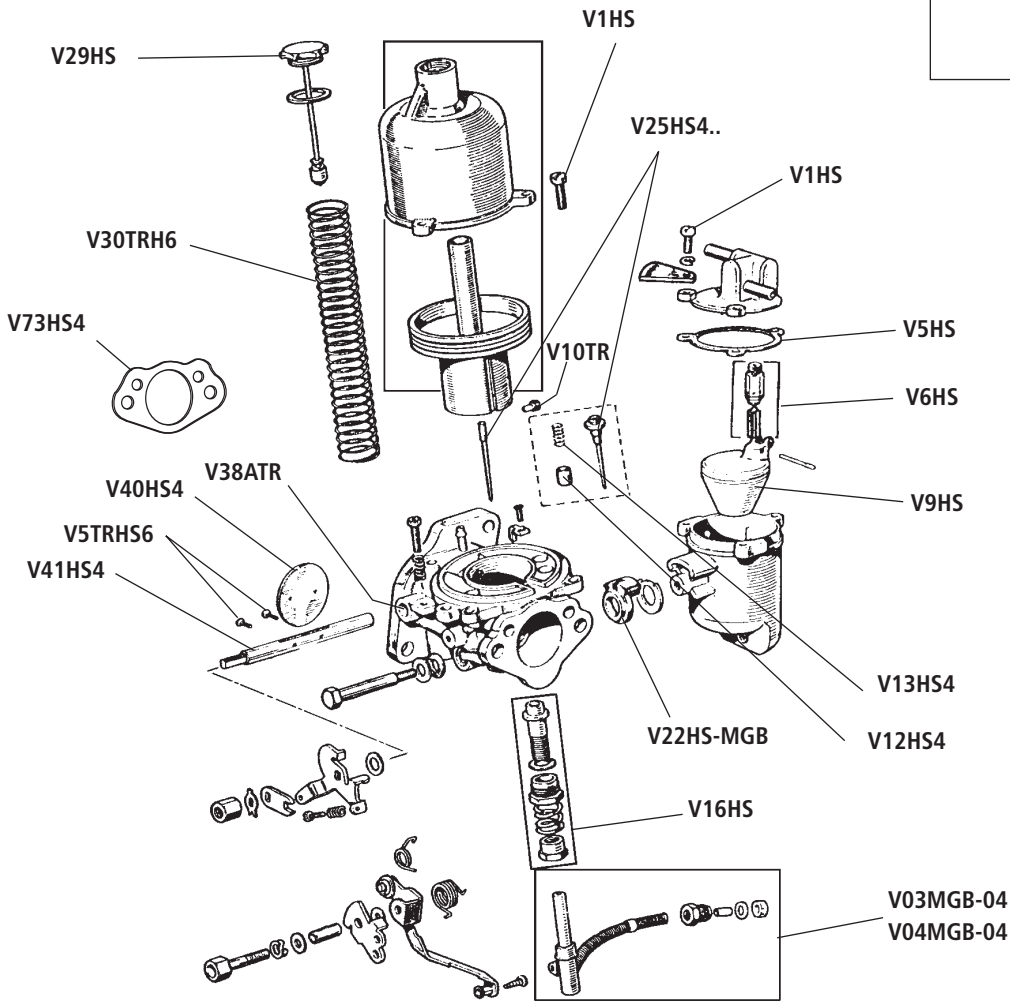
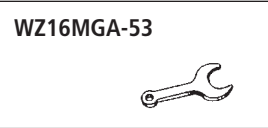

V80HS4

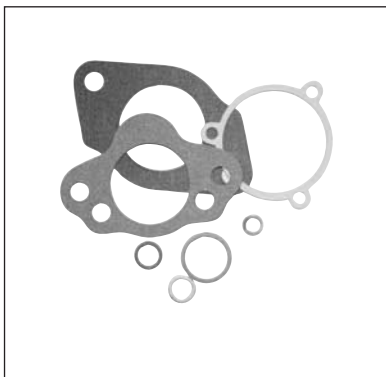

V81HS4-MGB



WZ75

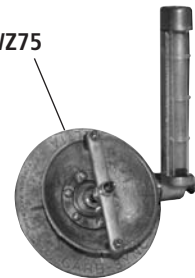

HIF4 (ab 1974)

HIF4 (from 1974)

No.	Bezeichnung	Description	Anzahl/Qty.
V01MGB-HIF4	AT-Vergaser Satz HIF4 MGB *)	Carburettor kit exchange HIF4 *)	1
V1HS	Schraube Vergaserglocke	Screw	6
V1HIF4	Schraube Schwimmekammer	Screw to float chamber	8
V5HIF4	Dichtung Schwimmerkammer	Gasket float chamber	2
V5HS6	Schraube Drosselklappe	Screw disc retaining, throttle	4
V05MGB-04	Düsenstock HIF4 vorne (zu Kühler)	Jet HIF4 front	1
V05AMGB-04	Düsenstock HIF4 hinten	Jet HIF4 rear	1
V6HS	Schwimmernadelventil	Needle valve and seat kit	2
V10TR	Madenschraube Düsennadel	Screw needle locking	2
V10MGA-16	Fiberscheibe	Washer (fibre)	2
V12HS4	Führung Vergaser Nadelhalterung	Guide carburettor needle	2
V13HS4	Feder Vergaser-Nadel	Carburettor needle spring	2
V16HIF4	Einstellteil Düsenstock	Jet bearing kit	2
V19HIF4V	Vergaser-Schwimmer HIF4 vorne (zu Kühler)	Carburettor float HIF4 front	1
V19HIF4H	Vergaser-Schwimmer HIF4 hinten	Carburettor float HIF4 rear	1
V25HS4	Vergaser-Nadel - bitte Nadelbezeichnung angeben	Carburettor needle - please refer needle type/dimension	2
V29HS	Vergaserdämpfer	Carburettor damper	2
V38ATR	Buchse Drosselwelle 7,938 mm	Bush carburettor spindle .313"	4
V30TRH6	Vergaser-Kolben-Feder rot	Carburettor piston spring red	2
V40HS4	Drosselklappe	Disc, throttle	2
V41HIF4	Drosselklappenwelle HIF4	Throttle spindle HIF4	2
V80HIF4	Vergaserdichtsatz	Carburettor gasket pack	2
V81HIF4-MGB	Vergaser Rep.-Satz HIF4 (für 2 Vergaser)	Carburettor service kit HIF4 (for 2 carburettors)	2
WZ16MGA-53	Einstellschlüssel Vergaser-Gemisch	Adjusting tool mirror	A/R
WZ75	Vergaser-Synchro-Tester	Carburettor synchronizer	A/R
SU-VÖ	SU-Vergaseröl, 150 ml	Oil, SU carb. 150 ml	A/R

**Hinweis
Note:**

*) Durch die Vielzahl der verbauten Vergaser ist nur die Überholung Ihres vorhandenen eigenen Vergasers möglich. (Bearbeitungszeit ca. 4-6 Wochen)

*) Please note: Due to multiple variations of carburettors fitted on MGB models we can only offer to rebuild your existing carburettor. (Delivery time ca. 4-6 weeks)

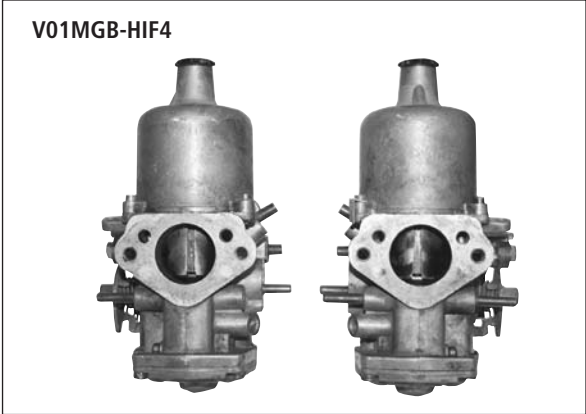
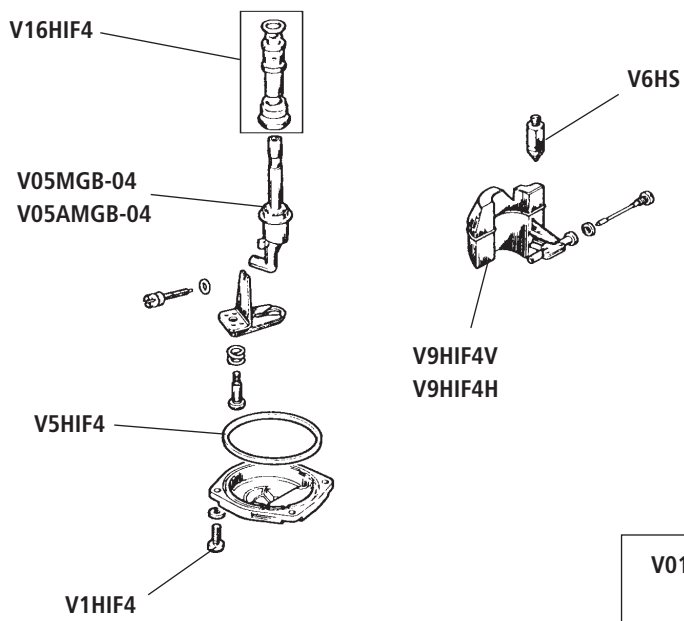
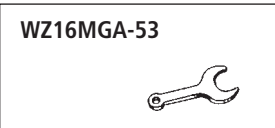
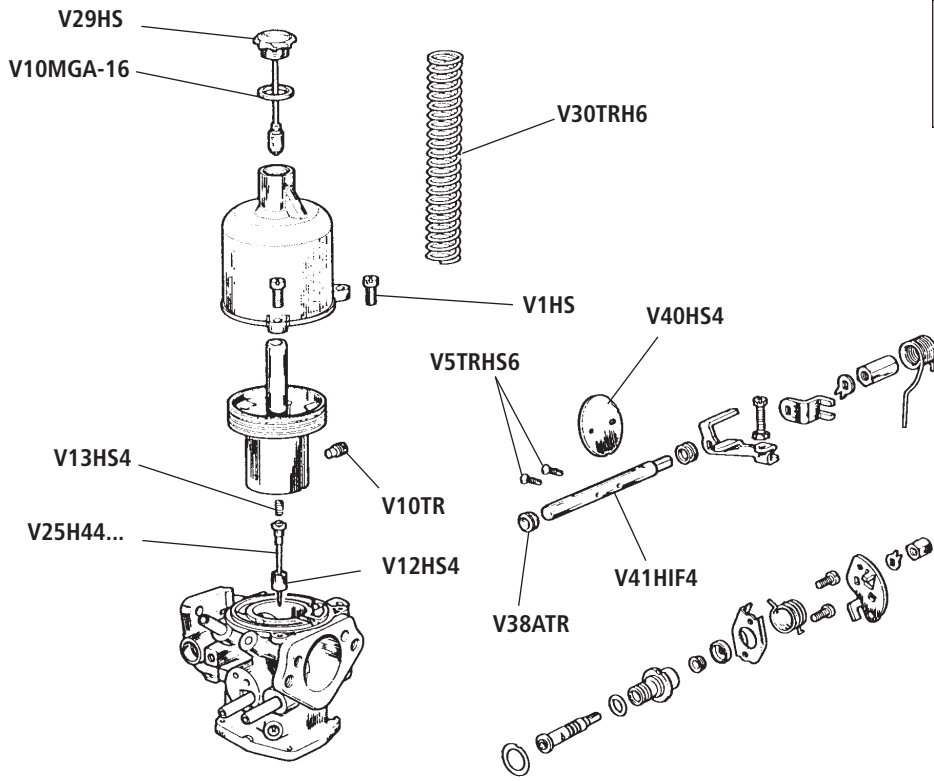

175CD5T USA

175CD5T US

No.	Bezeichnung	Description	Anzahl/Qty.
V0MGB-175CD	AT-Vergaser (1 Vergaser)	Exchange carburettor (1 carburettor)	1
V1TR175CD	Vergaserdämpfer	Carburettor damper	1
V3TR175CD	Schraube	Screw	4
V4TR175CD	Feder	Spring	4
V8TR175CD	Membrane 175CDSE (Zenith)	Diaphragm 175CDSE (Zenith)	1
V10TR	Madenschraube Düsenadel	Screw needle locking	1
V26TR175CD	Schwimmernadelventil	Needle valve and seat kit	1
V29TR175CD2	Düse	Jet	1
V34MGB-04	Luftfilter-Element MGB US -o. Abb.	Air filter element MGB US -w/o illust	1
V35TR175CD2	Vergaser-Schwimmer 175CD2SE (Zenith)	Carburettor float 175CD2SE (Zenith)	1
V38ATR	Büchse Drosselklappenwelle	Bush carburettor spindle	2
V39TR175CD	Drosselklappe	Disc, throttle	1
E5SPT	Schraube Drosselklappe	Screw disc retaining, throttle	2
V39AMGB-04	Dichtung Luftfilterkasten -o. Abb	Gasket air filter box -w/o illust	1
V42MGB-04	Hitzeschild MGB US ab 1977 -o. Abb	Heatshield MGB US 1977 on -w/o illust	1
V60MGB-04	Vergaser-Nadel B45H Stromberg ab 75	Carburettor needle B45H Stromberg from 75	1
V83TR175CD2	Dichtung	Gasket	1
V90TR175CD2	Vergaser-Dichtsatz	Carburettor gasket pack	1
V91TR175CD2	Vergaserreparatursatz (1 Vergaser) = Dichtsatz, Nadelventil	Carburettor service kit (1 carb.) = gasket pack, needle valve	1
V92TR175CD2	Luftfilterdichtung	Gasket air filter	1
V110TR175CD2	Einstellschlüssel für Düsenadel	Carburettor adjusting tool	A/R

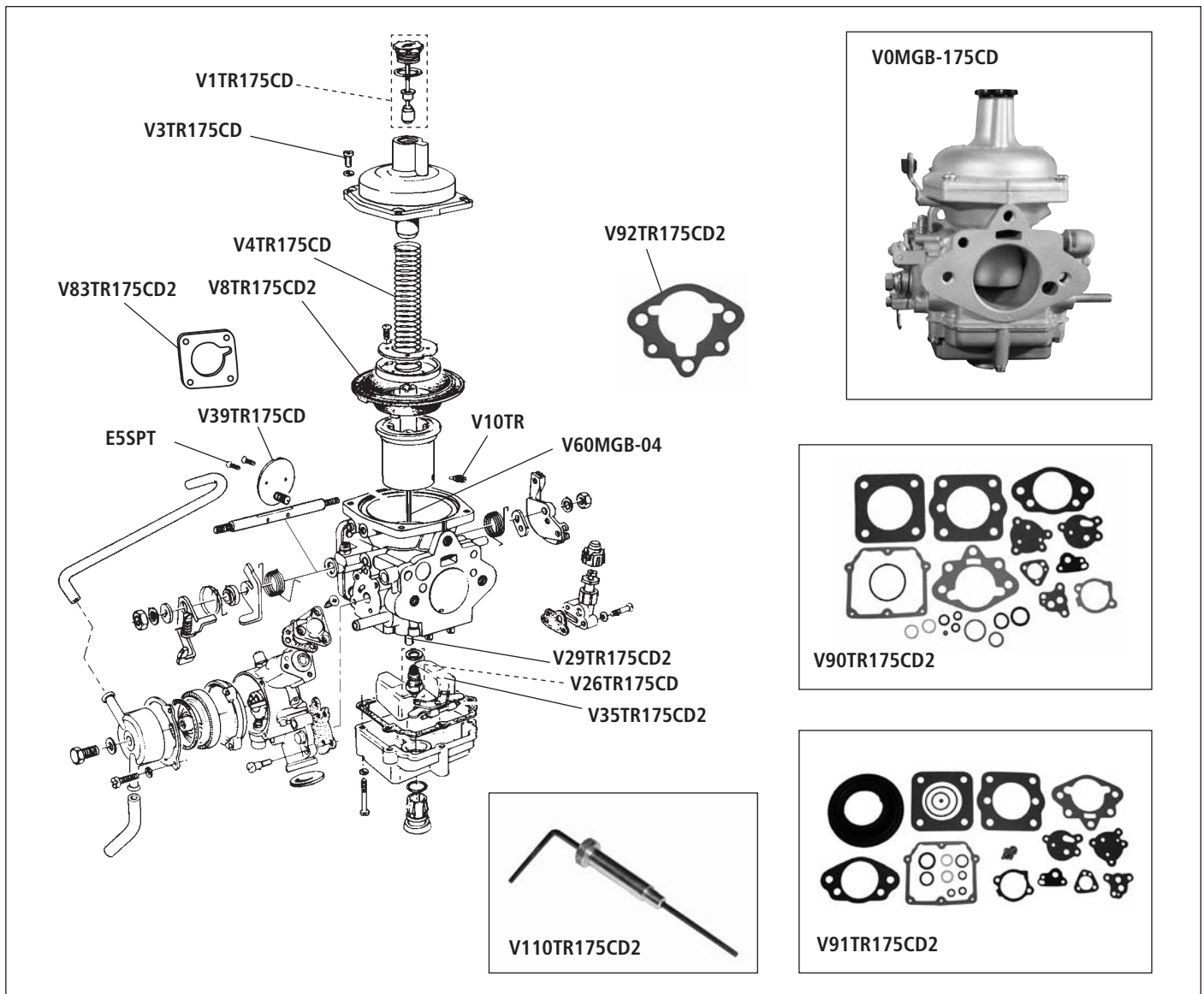

Weber DCOE 40, DCOE 45

No.	Bezeichnung	Description	Anzahl/Qty.
V3TRW	Weber DCOE40 mit Düsenbestückung	Weber DCOE40 with Needles, Jets	1
V4TRW	Weber DCOE45 mit Düsenbestückung	Weber DCOE45 with Needles, Jets	1
V5TRWMGB40	Umrüstsatz MGB auf Weber DCOE40 - beinhaltet 1 Vergaser DCOE40 und 1x Ansaugstutzen	Conversion Kit MGB to Weber DCOE40 contains 1 carburettor DCOE40 and 1x inlet manifold	1
V5TRWMGB45	Umrüstsatz MGB auf Weber DCOE45 - beinhaltet 1 Vergaser DCOE45 und 1x Ansaugstutzen	Conversion Kit MGB to Weber DCOE45 contains 1 carburettor DCOE45 and 1x inlet manifold	1
V7TRW	K+N Luftfilter Bauhöhe 55 mm	Air Filter K&N, height 55 mm	1
V8TRW-...	Luftkorrekturdüse (bitte Größe angeben)	Air correction jet (please refer size)	2
V9ATRW	Luftfilter-Dichtung	Gasket air filter	1
V10TRW	Chromluftfilter für Weber DCOE40/DOCE45	Air Filter , chrome, Weber DCOE40/DCOE45	1
V10TRW-...	Mischrohr (bitte Größe angeben)	Emulgation tube (please refer size)	2
V11TRW-...	Leerlaufdüse (bitte Größe angeben)	Idle speed jet (please refer size)	2
V12TRW-...	Hauptdüse (bitte Größe angeben)	Main jet (please refer size)	2
V15TRW	Schwimmer	Float	1
V20TRW	Rückholfeder Drosselklappenwelle	Return spring throttle shaft	1
V25TRW-...	Lufttrichter	Choke	2
V72TRW-...	Pumpendüse (bitte Größe angeben)	Pump jet (please refer size)	2
V90TRW	Vergaserdichtsatz für Weber DCOE	Carburettor gasket set Weber DCOE	1
V91TRW	Vergaserreparatursatz Weber DCOE incl. Schwimbernadelventil	Rebuilt kit Weber DCOE including float needle jet	1
V100MGA	Ansaugstutzen für 1x Weber DCOE (MGA/MGB)	Inlet manifold, 1x Weber DCOE (MGA/MGB)	1
V110SPT	Gaszug Anbausatz Einfach-Zug	Carburettor fitting kit single-throttle	1
V111SPT	Gaszug Anbausatz Doppel-Zug	Carburettor fitting kit twin-throttle	1
V115TRW	O- Ring mit Metalleinlage zwischen Weber- Vergaser und Ansaugstutzen	O- ring with metal insert between Weber carburettor and inlet manifold	2

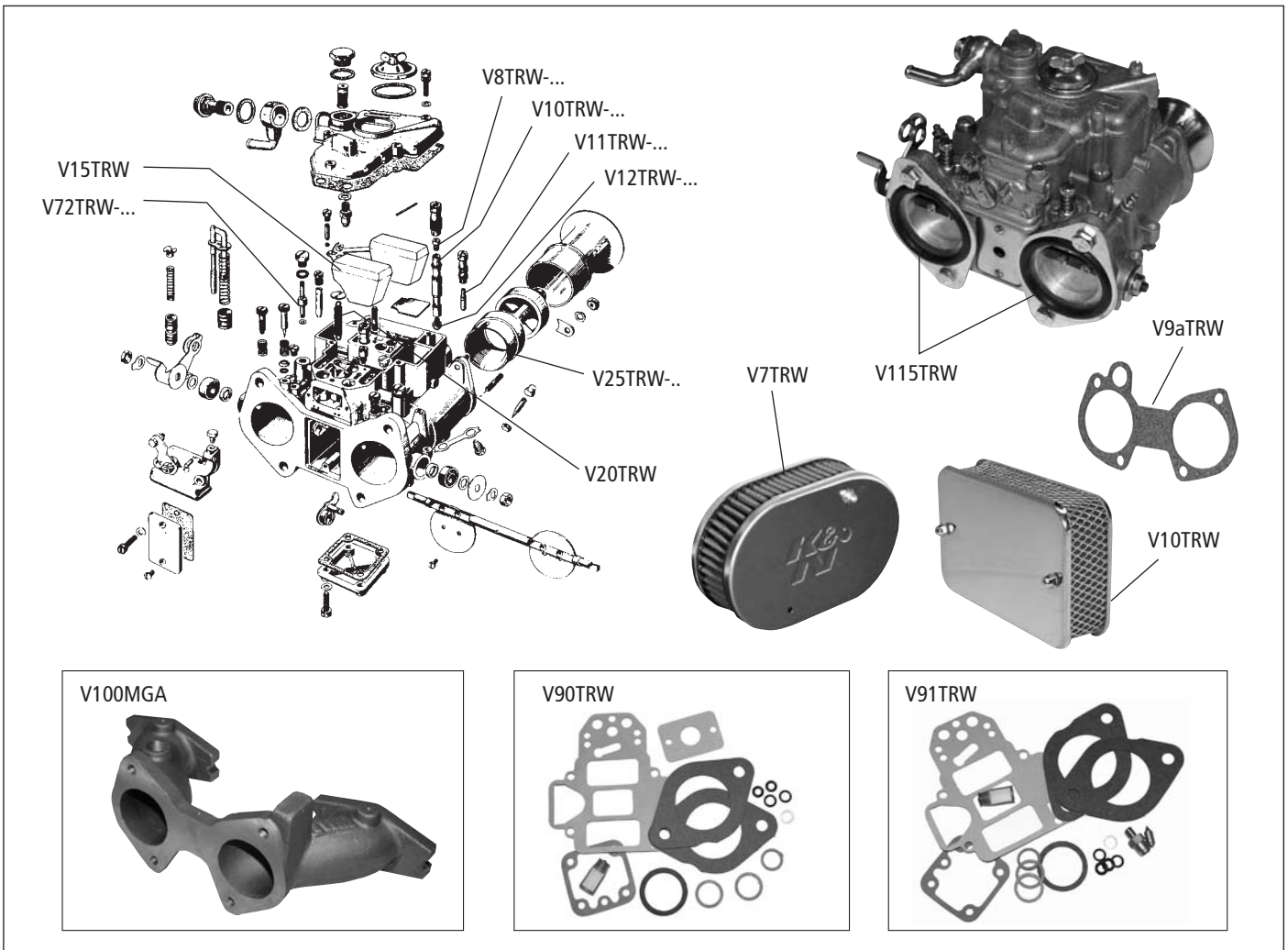

No.	Bezeichnung	Description	Anzahl/Qty.
W15	Chokezugnippel	Trunnion pin choke cable	1
V21MGB-03	Chokezug MGB bis 69	Choke cable MGB up 69	1
V22MGB-03	Chokezug MGB ab 69 bis 9/76	Choke cable MGB from 69 up to 9/76	1
V23MGB-03	Chokezug MGB ab 9/76	Choke cable MGB from 9/76	1
V24MGB-03	Gaszug MGB 62-67 HS4	Throttle cable MGB 62-67, HS4	1
V25MGB-03	Gaszug MGB 68-74 LHD (RD bis 360300, GT bis 361000)	Throttle cable MGB 68-74 LHD (RD to 360300 / GT to 361000)	1
V25AMGB-03	Gaszug MGB 74 LHD (RD ab 360301 / GT ab 361001)	Throttle cable MGB 74 LHD 74 (RD 360301 on / GT 361001 on)	1
V26MGB-03	Gaszug MGB ab 74 LHD Stromberg (bis 428510)	Throttle cable MGB 74 on LHD, Stromberg (to 428510)	1
V26AMGB-03	Gaszug MGB ab 74 Stromberg (ab 428511)	Throttle cable MGB 74 on, Stromberg (428511 on)	1
V27MGB/RHD	Gaszug MGB RHD 2 x HIF-Vergaser	Throttle cable MGB RHD 2 x HIF-carburettor	1
R28MGB-03	Gummi Gaspedal MGA/MGB 62-67	Pedal rubber (throttle) MGA/MGB 62-67	1
V29MGA-16	Vergaser-Hebel bis 18V.0518	Throttle lever up to 18V.0518	1
V32MGB-03	Vergaser-Gashebel MGB	Carburettor throttle lever MGB	1
V33MGA-16	Führungssockel Gaszug an Karosserie	Guide throttle cable	1
V37MGA-16	Gaszug -Endstück	Throttle link pin	1
V71HS	Vergaser-Rückholfeder	Carburettor spring throttle return	2
RT5/8"	Kabeltülle 5/8" (16 mm)	Cable spout 5/8" (16 mm)	A/R
RT3/8"	Kabeltülle 3/4" (19 mm)	Cable spout 3/4" (19 mm)	A/R

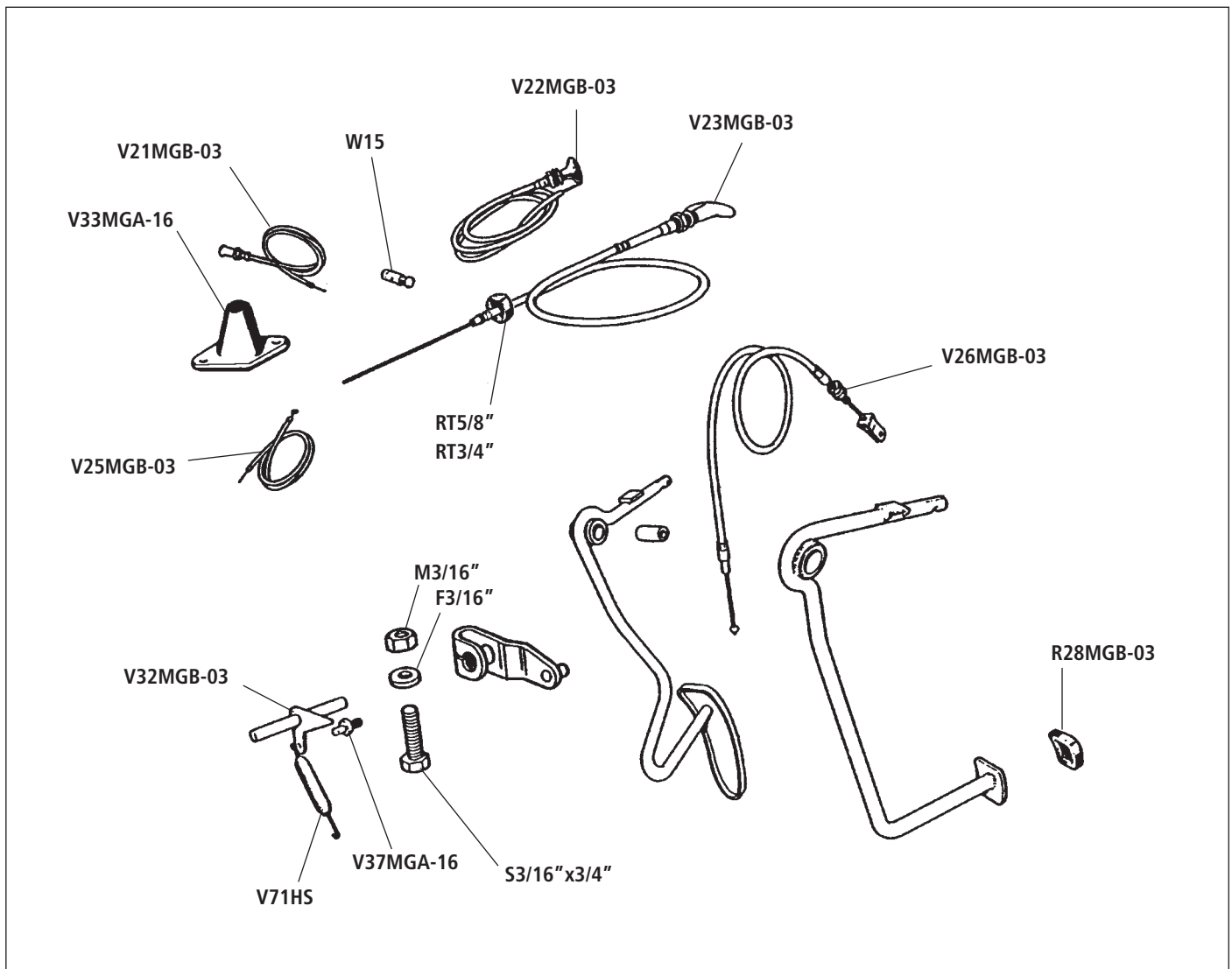

Classic Tuning für Straße, Rallye und Rennsport

Neben unserem umfangreichen Fahrzeugteile-Programm für den "normalen" Straßeneinsatz bieten wir auch Rennsport- und Tuningteile an, bis hin zu leistungsgesteigerten Motoren für Wettbewerbszwecke!

Fragen Sie einfach nach - wir beraten Sie gerne!

Unser Tipp: News und Termine für Motorsport-Interessierte auf unseren Webseiten: www.bastuck.com

Classic Tuning for Road, Rally & Racing

Apart from our standard parts for the "everyday"-use we offer lots of competition parts for road, rally or racing. We can supply a wide range of high performance engine parts but also competition engines ready for your racing weekend.

Please feel free to contact us - we can help you!

Our tip: News and race terms on our websites: www.bastuck.com



MG Rennsportzubehör / Racing Accessories

No.	Bezeichnung
Überrollbügel und -käfige, ab Lager lieferbar!	
T100MGB	Überrollbügel mit DMSB/FIA Zertifikat
T100aMGB	Überrollkäfig mit DMSB/FIA Zertifikat

No.	Description
Built to order rollcages and arcs - available from stock!	
T100MGB	Roll arc DMSB/FIA certificated
T100aMGB	Roll cage DMSB/FIA certificated

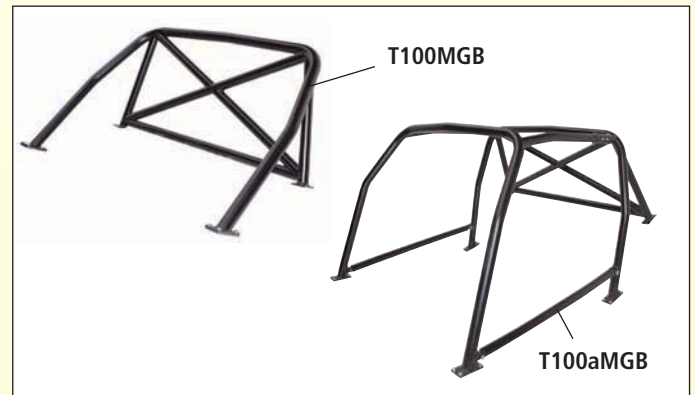

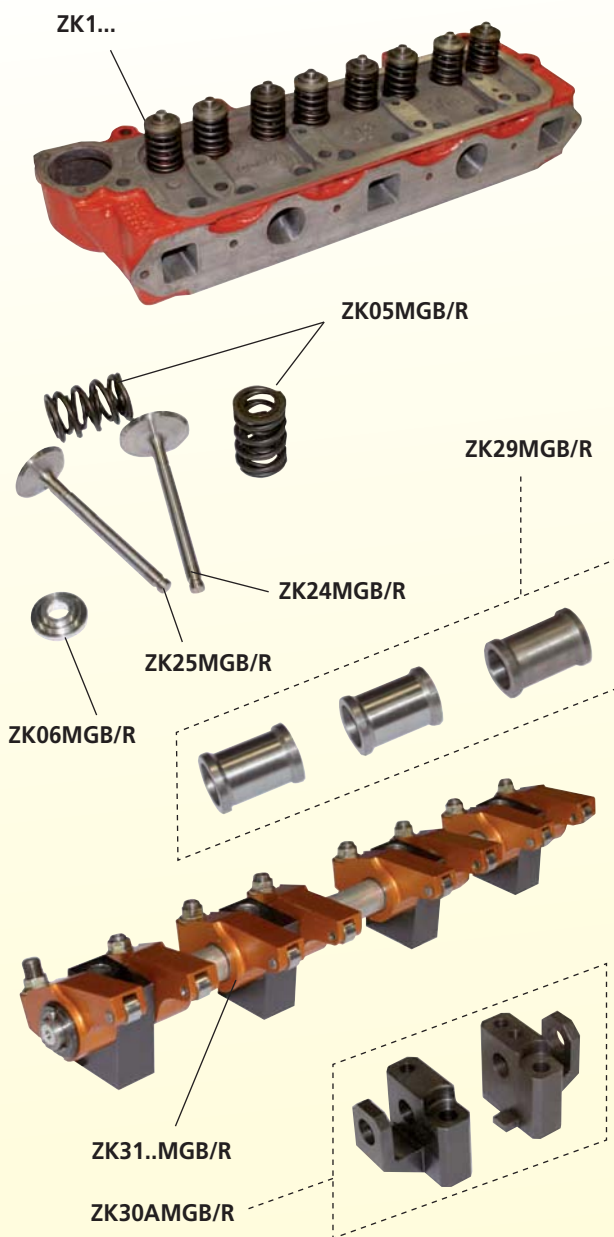

Rennsportzubehör

No.	Bezeichnung
T57...	Aluminium-Pedalaufgabe Satz (verschiedene Farben)
T98...	Textilklebeband (verschiedene Farben)
T120	Handfeuerlöscher OMP Eco Life, AFFF Gewicht 4,9 kg - Inhalt 2,64 kg
T150	Motorhaubenhalteset
T150A	Motorhaubenhalteset Aluminium
T151	Federhalter mit Haken für Kofferraumdeckel
T152	Hauptstromschalter 6-polig
T160B	Facet Benzinpumpe "Blue Top"
T160R	Facet Benzinpumpe "Red Top"
T160S	Facet Benzinpumpe "Silver Top"
T160-1/4	Anschluß 1/4NPT für T160B und T160R
T160-1/8	Anschluß 1/8NPT für T160S
T161	"Filter King" Druckregler incl. Benzinfilter
T845	Hitzeschutzband 50 mm, Rolle ca. 15 m
T847	Hitzeschutzband 25 mm, Rolle ca. 15 m
T4520/58	Fliebertankdeckel abschliessbar, Ø 58 mm, 6 Befestigungslöcher, für 2"-Anschluß
T4520/76	Fliebertankdeckel abschliessbar, Ø 76 mm, 8 Befestigungslöcher, für 2"-Anschluß
T4522	Schraubenset V2A für Tankdeckel T4520/58 und T4520/76 (8 Schrauben)

Zylinderkopf

ZK1MGB/R	AT-Zylinderkopf mit Kipphebelgalerie Ölbohrung in Reihe *)
ZK1AMGB/R	AT-Zylinderkopf mit Kipphebelgalerie Ölbohrung versetzt *)
ZK1MGB/FR	AT-Full Race Zylinderkopf wie ZK1MGB/R, aber für Rennfahrzeuge optimiert
ZK1AMGB/FR	AT-Full Race Zylinderkopf wie ZK1AMGB/R, aber für Rennfahrzeuge optimiert
ZK05MGB/R	Satz doppelte Ventildistanzfedern für Nockenwelle über 7,5 mm Nockenhub
ZK06MGB/R	Passender Ventilteller für ZK05MGB/R-Ventilfedern
ZK07MGA-08	Aluminium Ventideckel
ZK27MGA-09	Satz Bronze Ventileführungen, strömungsgünstig und mit besseren Notlaufeigenschaften
ZK24MGB/R	Strömungsgünstiges Einlaßventil Ø 43 mm (1.70")
ZK25MGB/R	Strömungsgünstiges Auslaßventil Ø 35 mm (1.45")
ZK29MGB/R	Satz Kipphebelstanzhülsen (ersetzt Original Federn)
ZK30MGB/R	Paar verstärkte, äußere Kipphebelböcke (für Zyl.-köpfe mit "in line" befindlicher Ölbohrung) Schema A
ZK30AMGB/R	Paar verstärkte, äußere Kipphebelböcke (für Zyl.-köpfe mit "versetzter" Ölbohrung) Schema B
ZK31MGB/R	Rollengelagerte Kipphebelwelle (Schema A)
ZK31AMGB/R	Rollengelagerte Kipphebelwelle (Schema B)
ZK50MGB/R	Satz hochfeste Zylinderkopf-Stehbolzen + Muttern
ZK65SPTR	Zylinderkopfmutter hochfest
ZK66SPTR	Unterlegscheibe hochfest für ZK65SPTR

Spezial-Dichtungen:

M26MGB/1950	Zylinderkopfdichtung für 1950 ccm-Motoren -o. Abb.
ZK38MGA/R	Einlaß/Auslaßdichtung für Zylinderköpfe mit -o. Abb. vergrößerten Kanälen

*) mit größeren Ventilen, überarbeitetem Brennraum, überarbeiteten Einlass/ Auslasskanälen, neuen Ventileführungen und verstärkten Ventildistanzfedern

Ölbohrung / Oil feed sheme

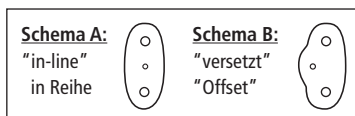

*) equipped with: bigger sized valves, revised ports and chambers, new valve guides and double valve springs

Racing Accessories

Description	Anzahl/Qty.
Aluminium pedal plates, various colours	A/R
Textile tape, various colours	A/R
Fire extinguisher OMP Eco Life, AFFF	1
Weight: 4,9 kg - Content: 2,64 kg	
Bonnet holders, set	1
Aluminium bonnet holders, set	1
Luggage boot holders, spring and hook	1
Main current switch, 6-pole	1
Fuel pump "Blue Top"	1
Fuel pump "Red Top"	1
Fuel pump "Silver Top"	1
Connection 1/4NPT for T160B and T160R	2
Connection 1/8NPT for T160S	2
Fuel pressure regulator "Filter King" with fuel filter	1
Heat shield tape 50 mm, Reel ca. 15 m	A/R
Heat shield tape 25 mm, Reel ca. 15 m	A/R
Aviation tank cap, lockable, Ø 58 mm, 6 mounting holes, 2" connector	1
Aviation tank cap, lockable, Ø 76 mm, 8 mounting holes, 2" connector	1
Screw set, inox, for tank caps T4520/58 and T4520/76 (8 screws)	1

Cylinder Head

Exchange cylinder head rocker gallery with In-Line oil feed *)	1
Exchange cylinder head rocker gallery with Offset oil feed *)	1
Exchange cylinder head Full Race - like described in ZK1MGB/R, dedicated for racing	1
Exchange cylinder head Full Race - like described in ZK1AMGB/R, dedicated for racing	1
Fast Road/Sport valve springs set, camshaft with cam lift 7,5 mm and more	1
Collar for valve spring no. ZK05MGB/R	8
Aluminium rocker arm cover	1
Bronze valve guides set	
Intake valve, air jet optimized, Ø 43 mm (1.70")	1
Exhaust valve, air jet optimized, Ø 35 mm (1.45")	4
Spacer set (replaces original spacer)	4
Uprated outer pedestal (cylinder head with "In-Line" oil feed) SHEME A	1
Uprated outer pedestal (cylinder head with "Offset" oil feed) SHEME B	1
Roller rocket set, "In-Line" oil feed (Scheme A)	1
Roller rocket set, "Offset" oil feed (Scheme B)	1
Uprated engine stud and nut kit	1
Uprated cylinder head nut	11
Uprated washer to no. ZK65SPTR	11

Special Gaskets:

Gasket cylinder head for 1950 cc	1
Gasket Inlet/Outlet for air flow revised cylinder heads with increased ports	1

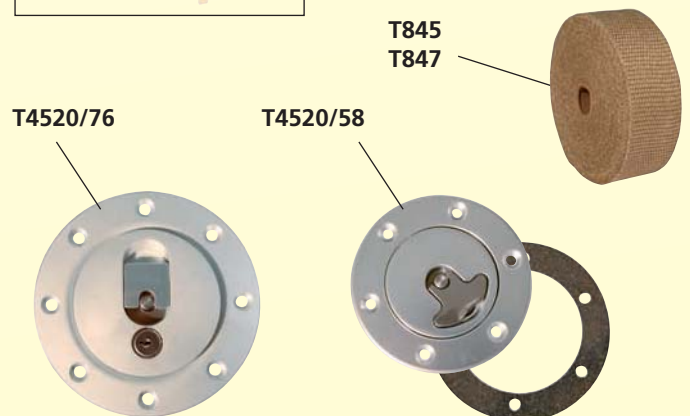
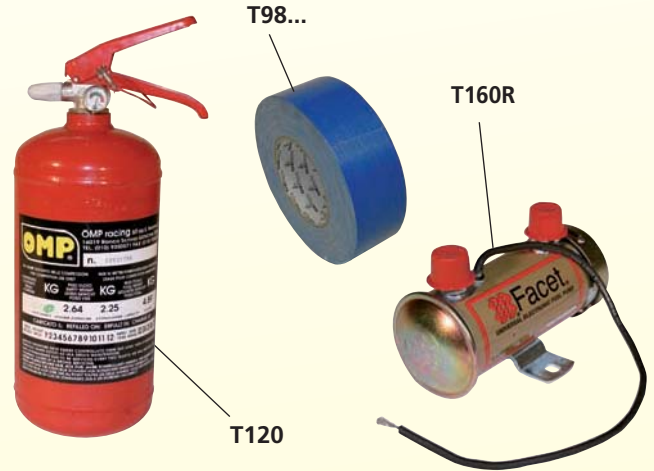
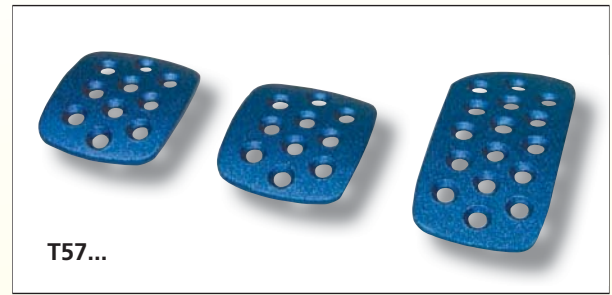
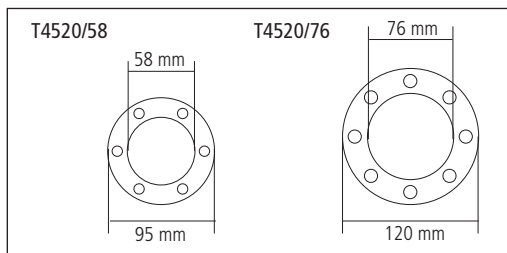

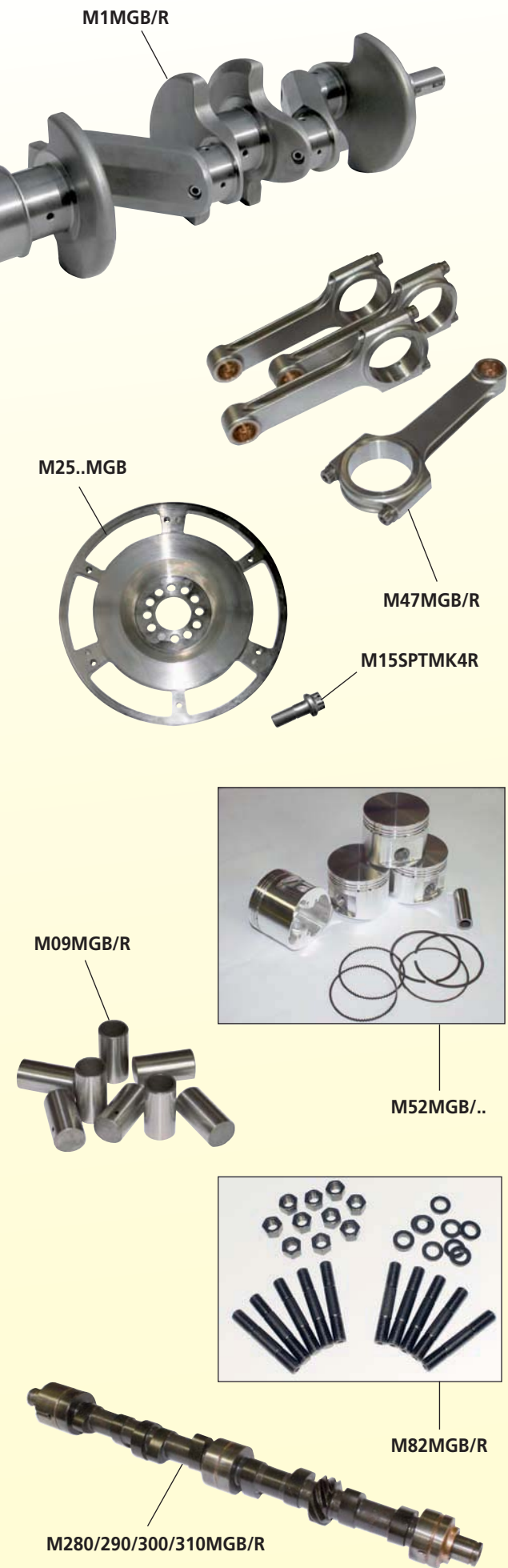

Motorblock

No.	Bezeichnung
M1MGB/R	Stahlkurbelwelle 5x Hauptlager
M25aMGB	Leichte Stahlschwungscheibe für Motoren mit 3x Hauptlagern (1962-64)
M25bMGB	Leichte Stahlschwungscheibe für Motoren mit 5x Hauptlagern, 3-Synchro-Getriebe (1964-67)
M25cMGB	Leichte Stahlschwungscheibe für Motoren mit 5x Hauptlagern, 4-Synchro-Getriebe (1967-80)
M47MGB/R	Motorsport-Pleuel, sehr leicht und unverwüßlich
M52MGB/STDR	Satz leichte, geschmiedete Kolben (1800 ccm)
M52MGB/1950R	Satz leichte, geschmiedete Kolben (1950 ccm)
M52MGB/1950	Satz Kolben (1950 ccm)

Nockenwellen

M280MGB/R	280° Sportnockenwelle 37/67 73/27 Steuerzeiten, 7.15 mm Nockenhub. Beste Nockenwelle für die Straße
M290MGB/R	290° Sportnockenwelle 42/68 78/32 Steuerzeiten, 7.84 mm Nockenhub. Geeignet für gut getunte Straßen- und Rallyemotoren
M300MGB/R	300° Sportnockenwelle 47/73 83/37 Steuerzeiten, 8.22 mm Nockenhub. Nockenwelle geeignet für Rundstrecke
M310MGB/R	310° Sportnockenwelle 52/68 88/42 Steuerzeiten, 8.6 mm Nockenhub. Die ultimative Rundstrecken-Nockenwelle

M09MGB/R	Erleichterter Stößelbecher
M10MGB/R	Leichte Rohrstoßelstange
M15MGA/R	Überarbeiteter Verteiler-Ölpumpenantrieb mit Spezial Bronze-Zahnrad
M15AMGA/R	Bronze Zahnrad separat für M15MGA/R
M15SPTMK4R	Befestigungsschraube Schwungscheibe, hochfest
M46MGA/R	Einstellbares Kettenrad Nockenwelle für doppelte Steuerkette
M82MGB/R	Stehbolzensatz Hauptlager, hochfest für 5-fach gelagerte Kurbelwelle
M103	Gradscheibe für Nockenwellen-Einstellung
M100MGB	Aluminium Ölwanne für 5x gelagerte Motoren
M110MGBA	Hintere Motorenplatte Alu für 5x gelagerte Motoren
M110AMGBA	Hintere Motorenplatte Alu für 3x gelagerte Motoren

Tilton Sport-Kupplungen

C2SPTRACE	Tilton Kupplungsautomat 7 1/4"
C2ASPTRACE	Anpressring für Tilton Kupplungsautomat einzeln
C2ASPTRACE205	Federnsatz für Tilton Kupplungsautomat einzeln
C3Tilton1"x23	Kupplungsscheibe Ø 7 1/4" mit 1" x 23 Zähne Aufnahme für Kupplungsautomat C2SPTRACE
C3MGBRACE	Sport Kupplungsscheibe (ungefedert) mit Carbon-Sintermetallbelag für Serien Kupplungsautomaten

Engine bloc

Description	Anzahl/Qty.
Steel crankshaft 5x bearing	1
Lightweight steel flywheel, 3x bearing engines (1962-64)	1
Lightweight steel flywheel, 5x bearing engines, 3-synchro gearbox (1964-67)	1
Lightweight steel flywheel, 5x bearing engines, 4-synchro gearbox (1967-80)	1
Connecting rod competition	4
Piston set, lightweight and forged (1800 cc)	4
Piston set, lightweight and forged (1950 cc)	4
Piston set (1950 cc)	4

Camshaft

280° Sports camshaft, timings: 37/67 73/27, tappet travel 7.15 mm. Best camshaft for road use	1
290° Sports camshaft, timings: 42/68 78/32, tappet travel 7.84 mm. For good optimized road and rallye engines	1
300° Sports camshaft, timings: 47/73 83/37, tappet travel 8.22 mm. Camshaft for round courses	1
310° Sports camshaft, timings: 52/68 88/42, tappet travel 8.6 mm. Ultimate camshaft for round courses	1
Lightened cam follower	8
Lightweight push rod	8
Reconditioned oil pump drive with special bronze gear	1
Bronze gear, separate for oil pump drive no. M15MGA/R	1
Flywheel screw, reinforced	6
Adjustable camshaft gear, for duplex timing chain	1
Uprated stud main cap, set - 5 x bearing engine	1
Cam timing degree disc	1
Alloy oil sump, 5x bearing engine	1
Alloy backplate, 5x bearing engine	1
Alloy backplate, 3x bearing engine	1

Tilton Sport Clutches

Tilton clutch cover 7 1/4"	1
Release bearing for Tilton clutch cover	1
Spring set for Tilton clutch cover	1
Clutch plate Ø 7 1/4" with 1" x 23 spline for fitting clutch cover C2SPTRACE	1
Sport clutch plate sintered for serial clutch cover	1

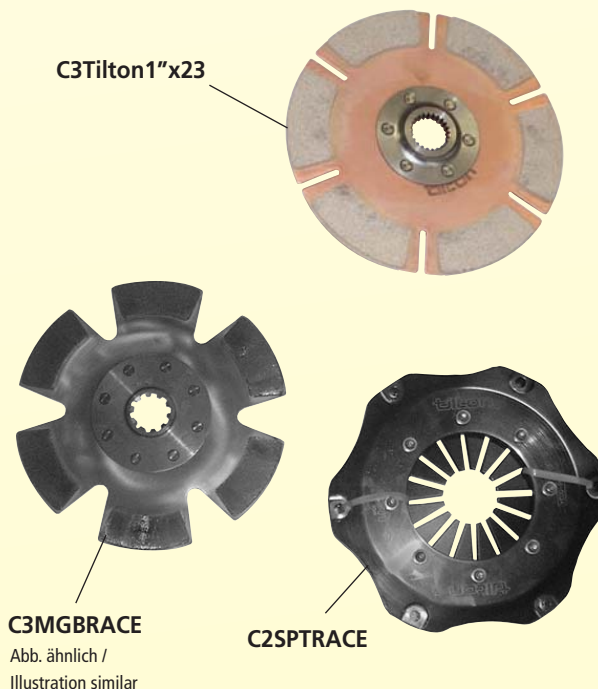
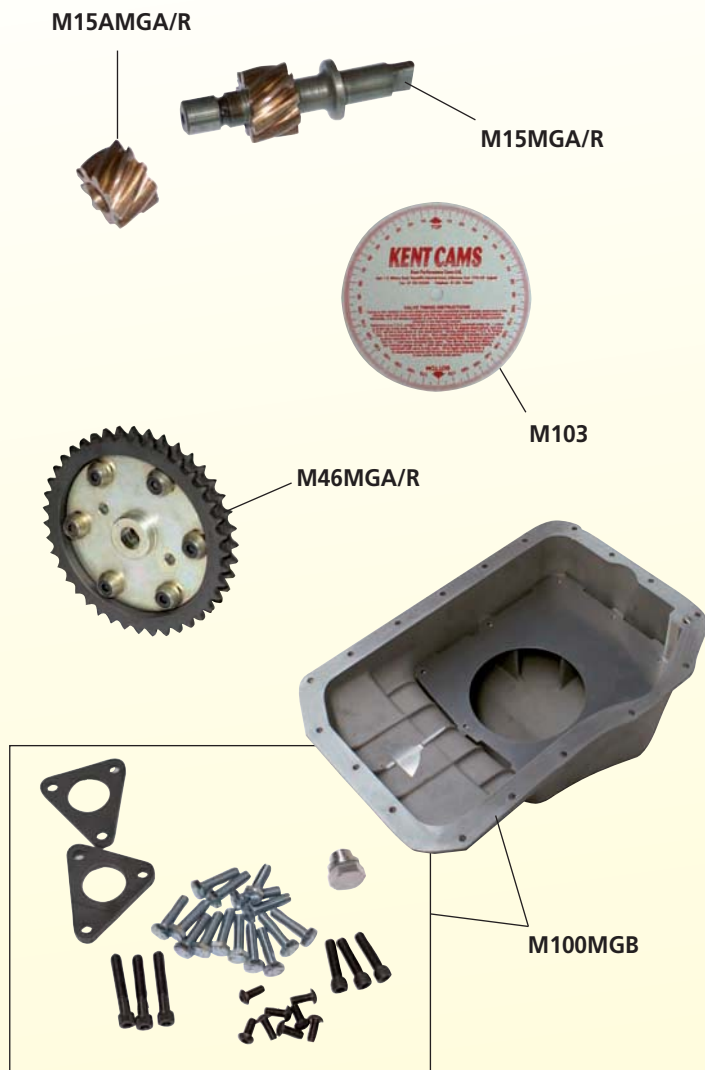

No.	Bezeichnung	Description	Anzahl/Qty.
V101MGB	Benzintank Roadster bis 62-65	Fuel tank Roadster up to 62-65	1
V102MGB	Benzintank Roadster + GT ab 65	Fuel tank Roadster + GT from 65	1
E150AMGB	Tankgeber Jäger Instrument bis GHN3 47462, 62-65	Tank unit for Jaeger gauge up to GHN3 47462, 62-65	1
E150BMGB	Tankgeber Smith Instrument ab GHN3 47463, 62-65	Tank unit for Smith gauge from GHN3 47463, 62-65	1
E150CMGB	Tankgeber bis GHN/D5 41500, ab 65	Tank unit up to GHN/D5 41500, from 65	1
E150DMGB	Tankgeber ab GHN/D5 41501, ab 65	Tank unit from GHN/D5 41501, from 65	1
E150BSPT	Halterung Tankgeber	Locking ring, tank unit	1
E150ATR3	Dichtung	Gasket	1
E150ASPT	Dichtung	Gasket	1
V05MGA-17	Membrane Benzinpumpe	Fuel pump diaphragm	1
V06MGA-17	Mutter	Nut elbow	2
K7	Schlauchschelle 8-12 mm für Benzinschlauch	Clip wire type 8-12 mm	A/R
SR14	Linsenkopfschraube 3/16" zu E150A+E150BMGB	Countersunk screw 3/16" tank unit/E150A+E150BMGB	A/R
K10B/SS	Schlauchschelle 50-70 mm	Clip wire type 50-70 mm	2
V20	Universal Benzinflter	Universal petrol filter	1
M27AMGA-12	Ablaßschraube bis 65	Drain plug up to 65	1
V37MGA-17	Verschraubung	Elbow, fuel pump	2
V50MGB	Tankdeckel	Filler cap	1
V50AMGB	Tankdeckel abschließbar	Filler cap lockable	1
V51AMGB	Dichtgummi Tankstutzen/Karosserie bis GHN/D5 392765	Seal filler to body up to GHN/D5 392765	1
V51BMGB	Dichtgummi Tankstutzen/Karosserie ab GHN/D5 392766 bis GHD 5451052	Seal filler to body from GHN/D5 392766 up to GHD 5451052	1
V51CMGB	Dichtgummi Tankstutzen/Karosserie ab GHN5 454203/GHD 5451053	Seal filler to body from GHN5 454203/GHD 5451053	1
V52AMGB	Tankstutzen bis GHN/D5 386600	Tankstutzen up to GHN/D5 386600	1
V52BMGB	Tankstutzen ab GHN/D5 386601	Tankstutzen from GHN/D5 386601	1
V53AMGB	Schlauch Tank/Tankstutzen bis GHN/D5 386600	Filler hose up to GHN/D5 386600	1
V53BMGB	Schlauch Tank/Tankstutzen von GHN/D5 386601 bis GHD 5451052	Filler hose from GHN/D5 386601 up to GHD 5451052	1
V53CMGB	Schlauch Tank/Tankstutzen ab GHN5 454203/GHD 451053	Filler hose from GHN5 454203/GHD 451053	1
V54AMGB	Dichtung Tankstutzen zu Tank bis 65	Seal tank neck up to 65	1
V54BMGB	Dichtung Tankstutzen zu Tank ab 65	Seal tank neck from 65	1
V55AMGB	Dichtung Ablassschraube bis 65	Washer drain plug up to 65	1
V56MGB	Verschußschraube	Drain plug	1
V61MGB	Tank Befestigungssatz	Mounting kit fuel tank	1
M61MGB	Dichtung Pumpengehäuse	Gasket pump base	1
M63MGB	Kontakte Satz Benzinpumpe	Point set, contacts	1
M64MGB	Haltegummi Benzinpumpe	Rubber, support	1
M65MGB	Halter Benzinpumpe	Bracket, fuel pump	1
M66MGB/F	Benzinpumpe früh	Fuel pump early	1
M66MGB	Benzinpumpe	Fuel pump	1
M66AMGB	Benzinpumpe Repro, +/- Erdung (Roadster ab GHN3 44439, alle GT ab 1964	Repro fuel pump +/- earth (Roadster from GHN3 44439, all GT from 1964)	1
M66BMGB/F	Benzinpumpe Repro, +/- Erdung (Roadster bis GHN3 44438 - 1962-64)	Repro fuel pump +/- earth (Roadster up to GHN3 44438 - 1962-64)	1
V32MGA-17	Anschluss Auslass für M66MGB/F	Union outlet for M66MGB/F	1
M70AMGB	Dichtung für Anschluss Auslass	Seal outlet union	1
M71MGB	Anschluss Einlass für M66MGB/F	Union inlet for M66MGB/F	1
M71AMGB	Dichtung für Anschluss Einlass	Seal inlet union	1
M72MGB	Schlauch zu Leitung bis 64	Hose pump to feed pipe, up to 64	1
M75MGB	Banjo Anschluß	Union banjo	2
M75AMGB	Dichtung	Sealing washer	4
M76MGB	Schraube Banjo Anschluß	Banjo bolt	2
M77MGB	Schlauch zur Leitung ab 64	Hose pump to feed pipe from 64	1
V77SPT	Benzinschlauch Ø 6 mm, je Meter	Fuel hose Ø 6 mm, per meter	A/R
V78SPT	Benzinschlauch Ø 8 mm, je Meter	Fuel hose Ø 8 mm, per meter	A/R
V78B	Dichtolive	Olive	2
V79SPT	T-Stück für 8 mm Benzinschlauch	T-piece for fuel hose/8 mm	1
V80MGB	Benzinleitung Benzinpumpe zu Spritzwand	Fuel pipe (pump to body)	1
V81MGB	Benzinleitung Spritzwand zum Filter	Fuel pipe (body to filter)	1

Roadster bis/up to GHN3 44438 (1962-64)

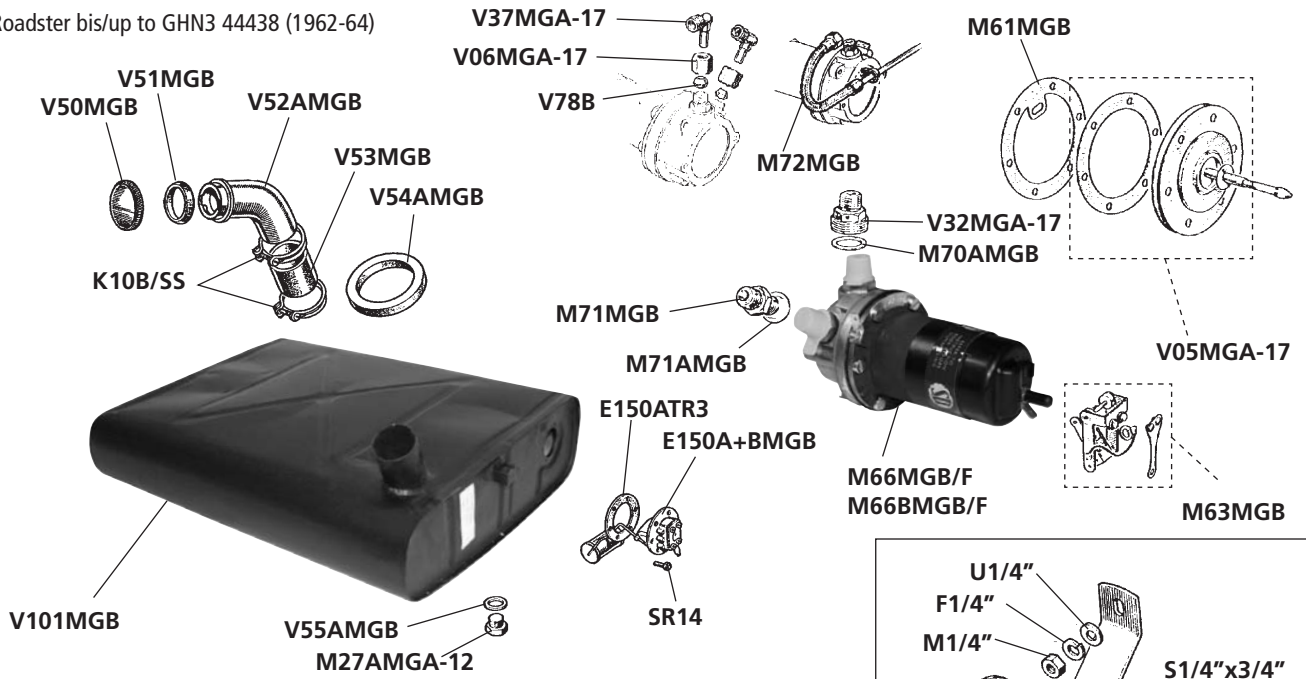

Roadster ab/from GHN3 44439 + alle GT (ab/from 1964)

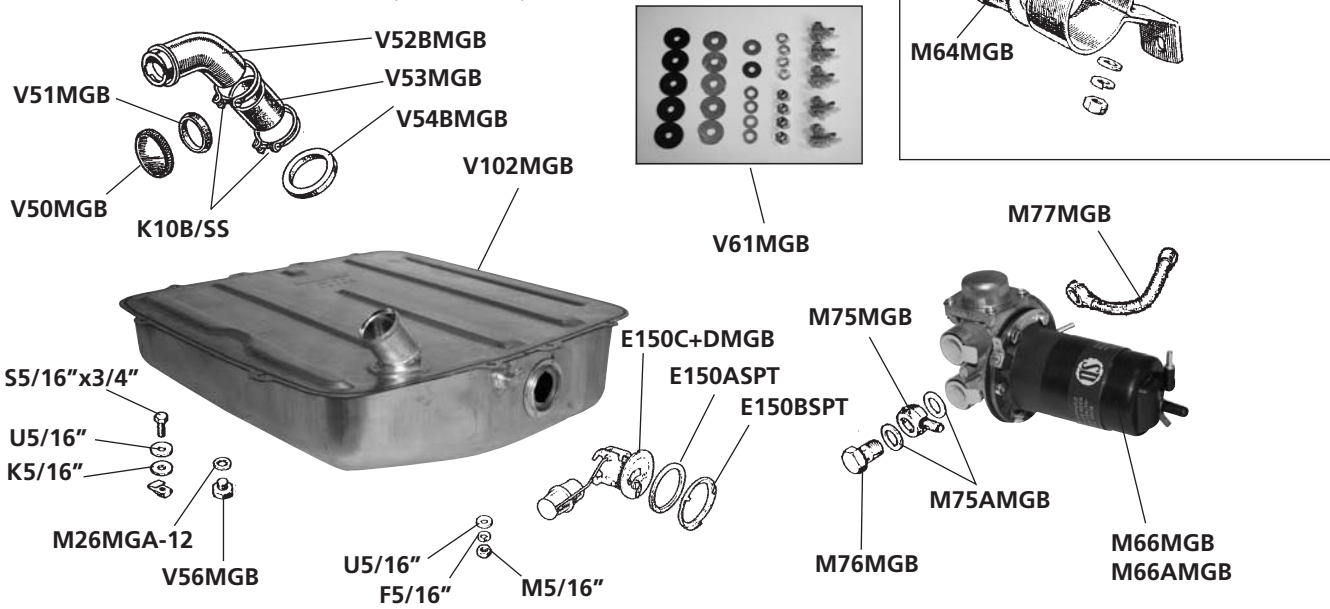

alle Modelle / all models

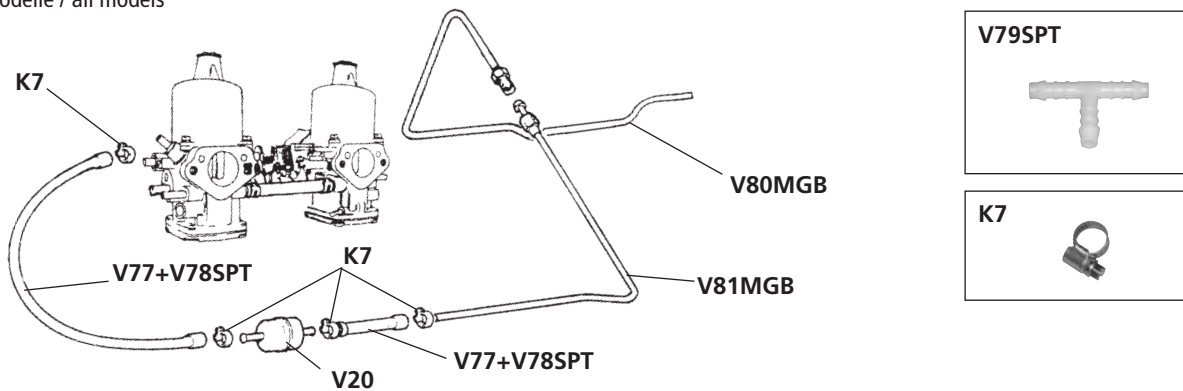

No.	Bezeichnung	Description	Anzahl/Qty.
K01MGB-12	Kühler MGB 62-67 (Deckel hinten)	Radiator MGB 62-67 (rear filler cap)	1
K01MGB/ALU	Aluminium Hochleistungskühler 62-67 (Deckel hinten)	High performance radiator assembly, alloy 62-67 (rear filler cap)	1
K02MGB-12	Kühler MGB 68-76 (Deckel in Mitte)	Radiator MGB 68-76 (cap in center)	1
K02MGB/ALU	Aluminium Hochleistungskühler 67-76 (Deckel mitte)	High performance radiator assembly, alloy 67-76 (cap in center)	1
K03MGB-12	Kühler MGB ab 76 für Fzge mit serienm. Elektrolüfter	Radiator MGB from 76 cars with serial. electric fan	1
K3VOB18	Kühler-Deckel 7 PSI 1" tief 62-67	Radiator cap 7 psi 1" deep 62-67	1
K4SPT	Wasser-Thermostat 74 °C	Water thermostat 74 °C	1
K4ASPT	Wasser-Thermostat 82 °C	Water thermostat 82 °C	1
K05AMGB-12	Kühler-Deckel 10 PSI 3/4" tief 67-76	Radiator cap 10 psi 3/4" deep 67-76	1
K05BMGB-12	Kühler-Deckel 13 PSI 3/4" tief 67-76	Radiator cap 13 psi 3/4" deep 67-76	1
K05MGB/L	Halterung Kühler, links	Stay, radiator LH	1
K05MGB/R	Halterung Kühler, rechts	Stay, radiator RH	1
K06MGB-12	Kühler-Verkleidung	Radiator surround	1
K08MGA-15	Kühler-Schlauch unten	Radiator hose bottom	1
K08MGA-15	Kühler-Schlauch oben	Radiator hose top	1
K08MGB-12	Gummidichtung Kühlerblech zu Kühler 67-76	Rubber seal diaphragm to radiator 67-76	1
K9SPT	Schlauch-Schelle 12-22 mm	Hose clip 12-22 mm	A/R
K9BSPT	Schlauch-Schelle 23-35 mm	Hose clip 23-25 mm	A/R
K09MGA-15	Verbindungsrohr Kühler-Schlauch 62-71	Water elbow radiator hoses 61-71	1
K10SPT	Schlauch-Schelle 30-45 mm	Hose clip 30-45 mm	A/R
K10MGA-15	Anschlußteil Heizschlauch	Union heater hose	1
K10MGB-12	Kühler-Schlauch unten 71-76	Radiator hose bottom 71-76	1
R11MGB-29	Gummi-Dichtung Kühlerblech zur Motorhaube	Rubber seal radiator to bonnet	1
K12MGB-12	Lüfterflügel Metall für Wasserpumpe	Propeller fan metal for water pump	1
K13MGA-15	Wasserschlauch zu Kniestück 62-71	Hose pump to elbow 62-71	1
K13MGB-12	Distanz-Hülse Ventilator	Spacing tube fan	4
K13AMGB-12	Gummi-Buchse Ventilator	Rubber bush fan	4
K13BMGB-12	Sicherungsblech Metalllüfter	Lock washer fan	2
K14MGB-12	Lüfterflügel Kunststoff für Wasserpumpe 18V ab GHN5 345 391	Propeller fan plastic for water pump 18V from GHN5 345 391	1
K15MGB-12	Keilriemen MGB US mit elektr. Kühlerventilator (Gummistoßstangen-Modell)	Fan belt MGB US with electric fan for rubber bumper model	1
K16MGB-12	Wasserpumpe 18G/18GA 62-64	Water pump 18G/18GA 62-64	1
K16AMGB-12	Wasserpumpe MGB 18GB bis 18GG 64-71	Water pump MGB 18GB to 18GG 64-71	1
K16BMGB-12	Wasserpumpe 18V ab 1971	Water pump 18V from 1971	1
K16CMGB-12	Dichtung Wasserpumpe für K16MGB-12	Gasket water pump/crankcase for K16MGB-12	1
K16DMGB-12	Dichtung Wasserpumpe für K16AMGB-12 + K16BMGB-12	Gasket water pump for K16AMGB-12 + K16BMGB-12	1
K18MGA-15	Keilriemen für Chromstoßstangen-Modell	Fan belt for chrome bumper model	1
K18MGA-914	Keilriemen für Hochleistungslichtmaschine E310COMP (s. auch Seite 84-85)	Fan belt for high performance AC alternator no. E310COMP (please refer page 84-85)	1
K18MGB-12	Thermoschalter 76-79	Thermostat switch 76-79	1
K18AMGB-12	Dichtring Thermo-Schalter für K18MGB-12	Sealing bush thermostat switch for K18MGB-12	1
K19MGB-12	Thermo-Schalter ab 79	Switch fan from 79	1
K19AMGB-12	Gummi-Dichtung für Thermo-Schalter K19MGB-12	Rubber seal fan for switch K19MGB-12	1
K19CMGB-12	Klammer Ventilator-Schalter	Clip fan switch	1
K20MGB-12	Lüftermotor	Fan motor	1
K21MGB-12	Lüfterflügel	Radiator fan	1
K22MGA-15	Dichtung Thermostatgehäuse	Thermostat gasket	1
K23MGB-12	Haltebügel Gebläsemotor oben	Bracket fan motor, upper	1
K24MGB-12	Haltebügel Gebläsemotor unten	Bracket fan motor, lower	1
K25MGB-12	Schutzgitter Ventilator	Fan guard	1
K26MGB-12	Kühlerschlauch oben ab 76	Radiator hose top from 76	1
K27MGB-12	Kühlerschlauch unten ab 76	Radiator hose bottom from 76	1
K28MGB-12	Überlaufschlauch per Meter	Expansion hose 1 meter	1
K30MGA-15	Überlaufschlauch Kühler	Overflow hose radiator	1
K30MGB-12	Kühler-Deckel für Ausgleichsbehälter 15 PSI 3/4" tief	Radiator cap 15 psi 3/4" deep for expansion tank	1
K31MGB-12	Klammer Ausgleichbehälter	Clip expansion tank	1
K40TR4	Wasserablaßhahn	Water drain plug	1
K57MGB-12	Schlauchadapter zu Heizungsrohr	Hose adaptor to heater pipe	1
M108aAH	Hochleistungslüfterflügel Kunststoff, 5 Blätter - als Ersatz für K12MGB-12	high performance radiator assembly - to replace no. K12MGB-12	1

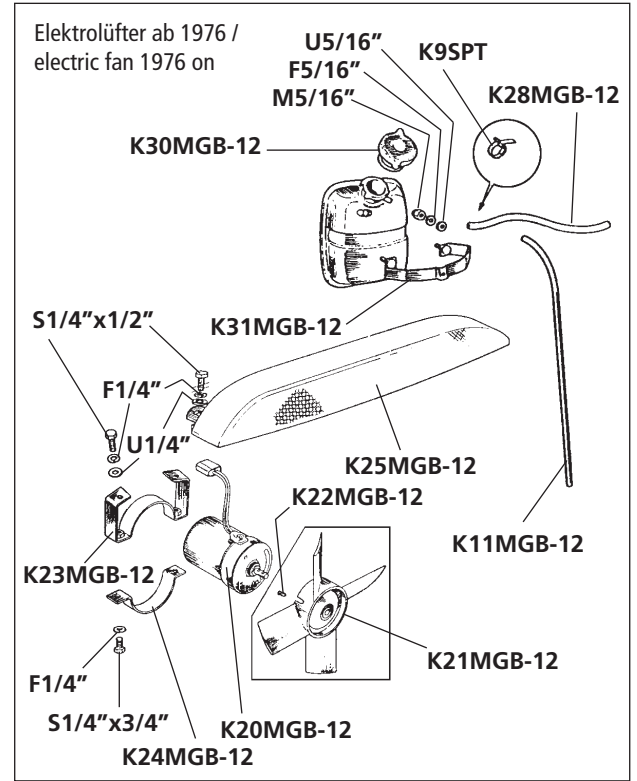
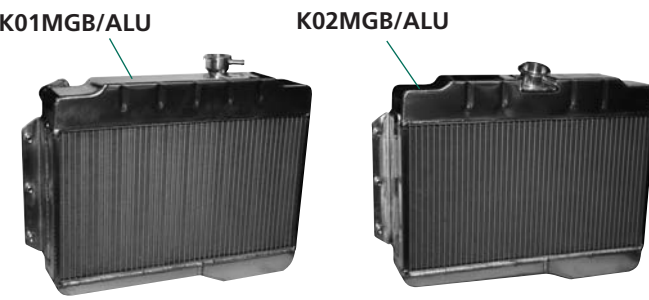
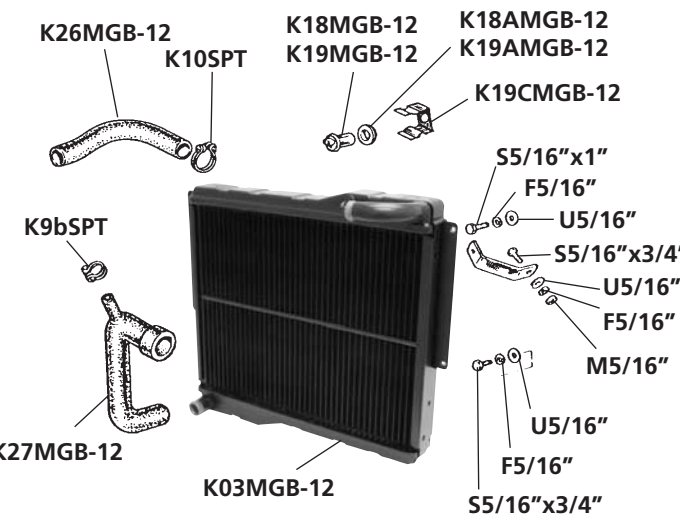
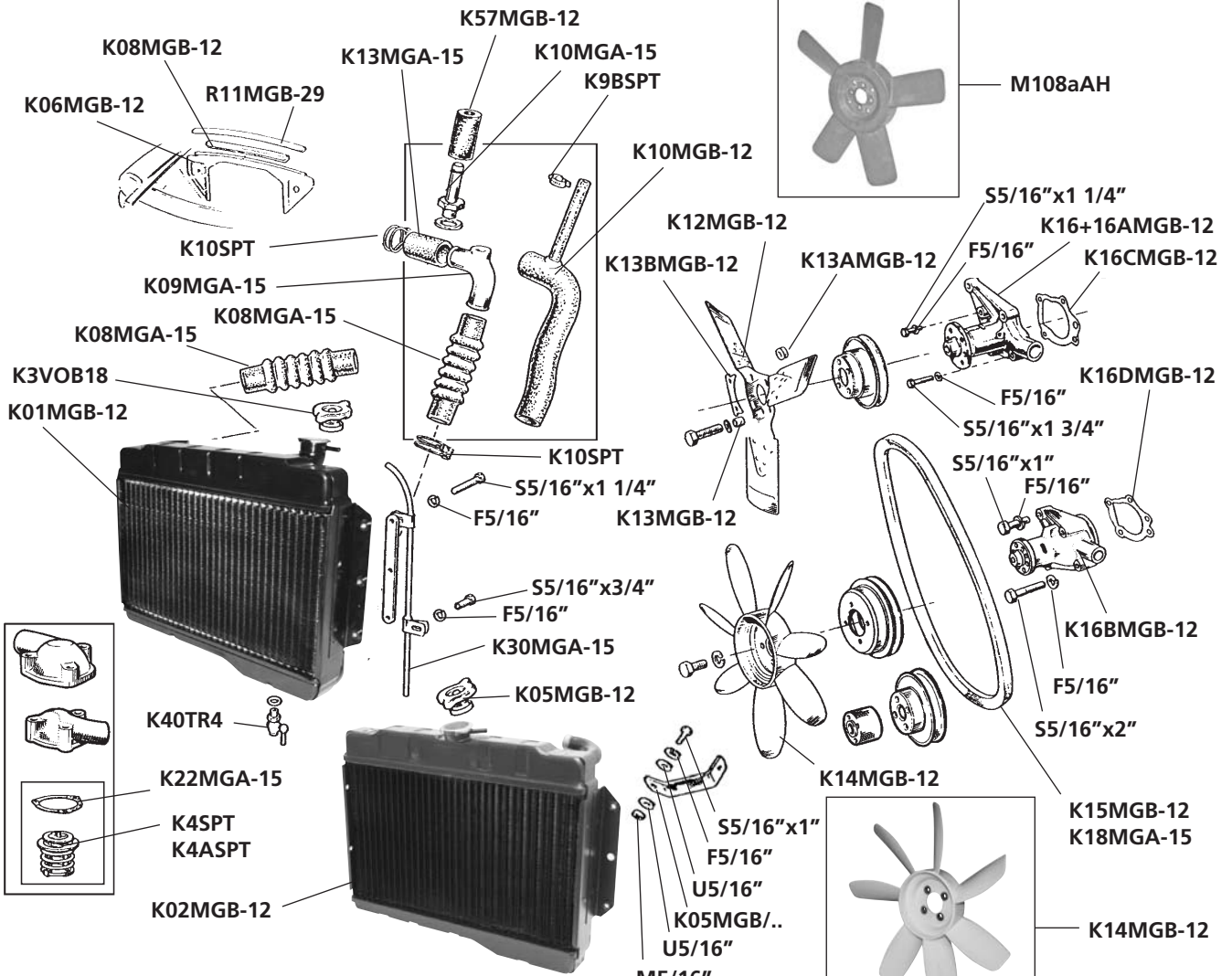

No.	Bezeichnung	Description	Anzahl/Qty.
K02MGB-13	Thermostat-Gehäuse 18GD ab 67 bis 9/76	Thermostat housing 18GD from 67 up to 9/76	1
K03MGB-13	Thermostat-Gehäuse ab 76	Thermostat housing from 76	1
K03MGA-32	Heizgebläse-Motor (o. Lüfterrad K08MGA-32)	Heater motor (w/o Rotor fan heater metal K08MGA-32)	1
K4SPT	Wasser-Thermostat 74 °C	Water thermostat 74 C.	1
K4ASPT	Wasser-Thermostat 82 °C	Water thermostat 74 C.	1
K04MGA-32	Wärmetauscher Heizung	Matrix heater	1
K04AMGA-32	Abdichtung Wärmetauscher zu Heizungsgehäuse	Foam pad heater radiator	1
K05MGA-32	Gummi-Dichtung Heizung	Rubber seal heater	2
K05MGB-13	Wasser-Einfüllkappe Kunststoff	Water filler cap plastic	1
K05AMGB-13	Wasser-Einfüllkappe Messing	Water filler cap brass	1
K06MGB-13	Scheibe Plastik	Washer plastic	1
K08MGA-32	Lüfter Heizungsgebläse	Rotor fan heater metal	1
K08MGB-13	Komplette Heizung	Heater assembly	1
K8ASPT	Schlauch 1/2", je Meter	Hose 1/2", per meter	A/R
K9SPT	Schlauchschelle 12-22 mm	Retaining clip 12-22 mm	A/R
K11MGB-13	Drehregler Heizung bis 9/76	Reostat switch heater up to 9/76	1
K11AMGB-13	Drehregler Heizung ab 9/76	Reostat switch heater from 9/76	1
K12MGB-13	Drehregler Luftzufuhr bis 9/76	Knob air rotary up to 9/76	1
K12AMGB-13	Drehregler Luftzufuhr ab 9/76	Knob air rotary from 9/76	1
K13AMGB	Knopf Heizung bis 74	Knob heater up to 74	1
K13BMGB	Knopf Heizung 74-76	Knob heater 74-76	1
K13CMGB	Drehknopf Heizung + Luftzufuhr ab 76	Knob heater + air rotary from 76 on	1
K14AMGB	Knopf Luftregler bis 70	Knob air up to 70	1
K15MGA-32	Endstück Heizungszug	Trunnion heater control cable	1
K14BMGB	Knopf Luftregler 70-74	Knob air 70-74	1
K14CMGB	Knopf Luftregler bis 74-76	Knob air 74-76	1
W15	Nippel Heizungszug	Trunnion heat control cable	1
K20MGB-13	Heizungszug	Heater control cable	1
K21MGA-15	Thermostat-Gehäuse bis 18GD 1967	Thermostat housing up to 18GD 1967	1
K22MGA-15	Dichtung Wasserthermostat	Gasket water thermostat	1
K24MGA-32	Heizungsventil	Heater control valve	1
K25MGA-32	Dichtung Heizungsventil	Gasket heater valve	1
K26MGB-13	Lüftungsschlauch	Demister hose	2
K27MGB-13	Dichtung	Seal	1
K28MGB-13	Schlauch zur Frischluftdüse in Armaturenbrett	Face level vent tube	2
K29MGB-13	Frischlufdüse Armaturenbrett rechts	Facia vent rh	1
K29AMGB-13	Frischlufdüse Armaturenbrett links	Facia vent lh	1
K30MGB-13	Heizungsrohr über Ventildeckel	Heater pipe above rocker cover	2
K33MGB-13	Winkelschlauch Frischluftzufuhr	Elbow demister	2
K36MGB-13	Gitter Lufteinlass Heizung	Mesh heater intake	1
K38MGB-13	Gummi-Dichtung Heizungslüfter	Rubber seal intake heater	1
K39MGB-13	Verbindungsschlauch	Connector tube	2
K40MGB-13	Gummi-Dichtung Heizungsdeckel	Rubber seal cover heater box	1
K41MGB	Dichtung Wärmetauscher ab 1970	Seal, radiator from 1970	1
K48MGA-32	Wasserrücklaufrohr	Water return pipe	1

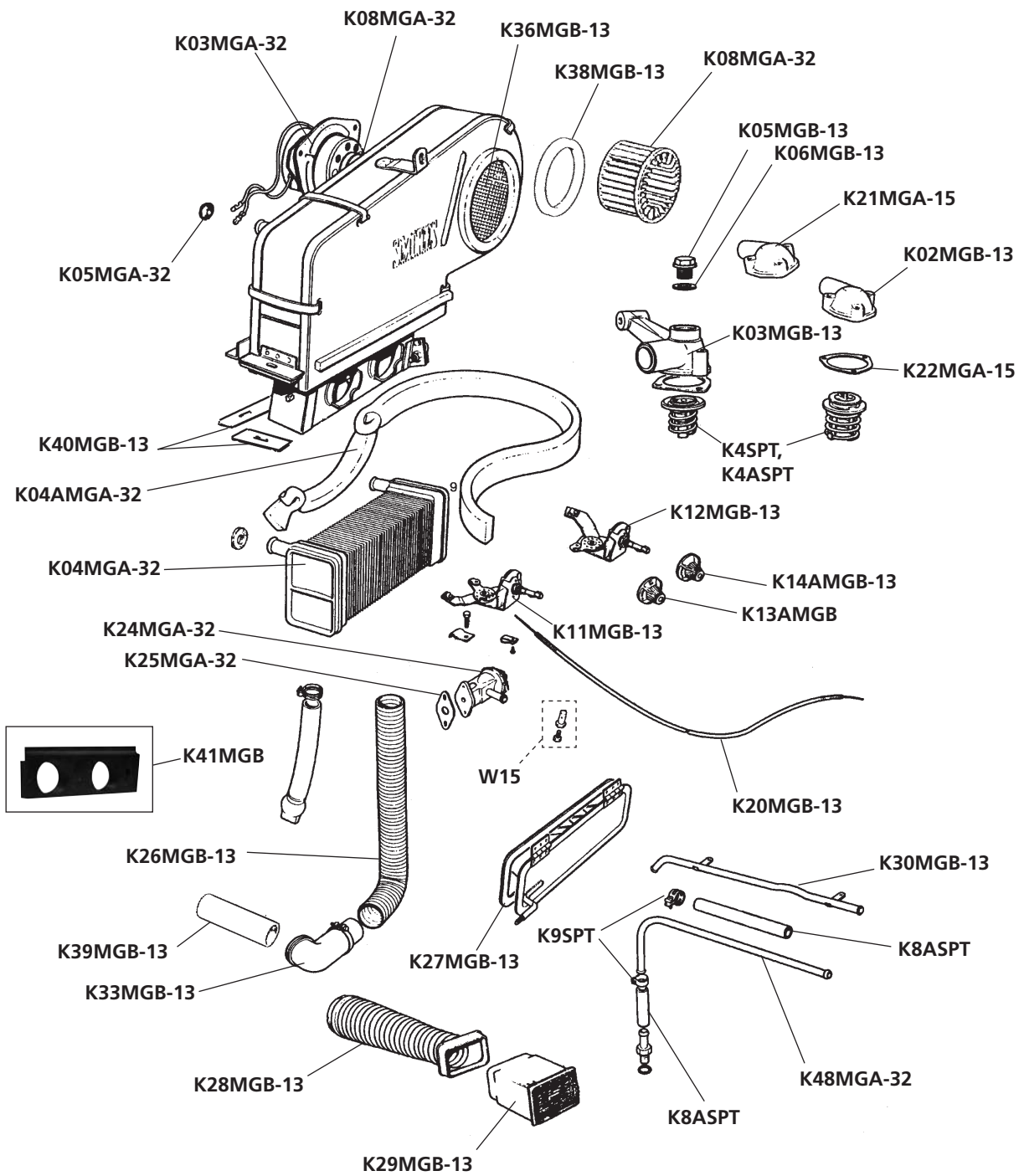

No.	Bezeichnung	Description	Anzahl/Qty.
C1MGB	Kupplungs-Satz (bestehend aus Kupplungsautomat, -scheibe und Ausrücklager)	Clutch kit (contents clutch cover, -plate and -bearing)	1
C2MGB	Kupplungs-Automat	Clutch cover	1
C3MGB	Kupplungsscheibe	Clutch plate	1
C4MGB	Kupplung-Drucklager	Clutch bearing	1
C11MGA-18	Buchse Kupplungs-Ausrückhebel	Bush clutch lever	1
C12MGB	Kupplungsleitung	Clutch pipe	1
C12MGC	Kupplungsleitung MGC-Modelle	Clutch pipe MGC models	1
C13MGA-18	Bolzen Kupplungs-Ausrückhebel	Nut nyloc UNF 3/8 x 31/64"	1
C15MGA-18	Mutter Nylon UNF 3/8 x 31/64"	Bolt clutch lever	1
C16MGA-18	Kupplungsnehmerzylinder	Clutch slave cylinder	1
C16MGC	Kupplungsnehmerzylinder MGC-Modelle	Clutch slave cylinder MGC models	1
C17MGA-18	Rep.-Satz Kupplungsnehmerzylinder	Repair kit clutch slave	1
B18MGA-22	Kontermutter	Lock nut	1
C18MGA-18	Ausrückstange Kupplungszyylinder	Push rod clutch cylinder	1
B21MGA-22	Dichtring Banjoverschluß	Banjo sealing	1
C21MGA-18	Entlüftungsnippel	Bleed screw	1
B22MGA-22	Hohlschraube	Banjo bolt	1
C25MGB-05	Halteclip Ausrücklager	Retainer clutch release bearing	2
C26MGB-05	Kupplungs-Hebel 3-Fach Synchro	Clutch lever 3-synchro	1
C27MGB-05	Kupplungs-Hebel 4-Fach Synchro, Austausch	Clutch lever 4-synchro, exchange	1
C29MGB-20	Kupplungsgeberzylinder bis 67	Clutch master cylinder up to 67	1
C29AMGB-20	Rep.-Satz zu Kupplungs-Zylinder C29+C30MGB-20	Repair kit clutch cylinder no. C29+C30MGB-20	1
C30MGB-20	Kupplungsgeberzylinder ab 67	Clutch master cylinder from 67	1
C31MGB-20	Hohlschraube Verbindung	Banjo bolt union	1
B34MGA-22	Klammer Bremsleitung Kunststoff	Clip brake pipe plastic	A/R
C35MGA-18	Kupplungszentrierwerkzeug bis 64	Tool clutch alignment up to 64	1
C35MGB-18	Kupplungszentrierwerkzeug ab 65 (5-Lager Motor)	Tool clutch alignment from 65	1
C36MGA-18	Manschette Kupplungshebel bis 74	Gaiter clutch fork up to 74	1
C36MGB-18	Manschette Kupplungshebel ab 75 (Gummistoßst. Modell)	Gaiter clutch fork from 75 (Rubber bumper model)	1
C36MGB-20	Lagerstift	Clevis pin	1
B56MG	Kupplungsschlauch	Clutch hose	1
B56MGAQ	Kupplungsschlauch stahlummantelt (alternativ)	Clutch hose steel reinforced (alternativ)	1
B56MGC	Kupplungsschlauch MGC-Modelle	Clutch hose MGC models	1
B58C	Kupferdichtung für Kupplungsschlauch	Copper washer for clutch hose	1
BR05	Bremsflüssigkeit 0,5 l	Brake fluid 0,5 l	A/R
BRBR	Hochleistungsbremsflüssigkeit "Blue Race" von ATE, pro Liter	High performance brake fluid ATE "Blue Race", per liter	A/R

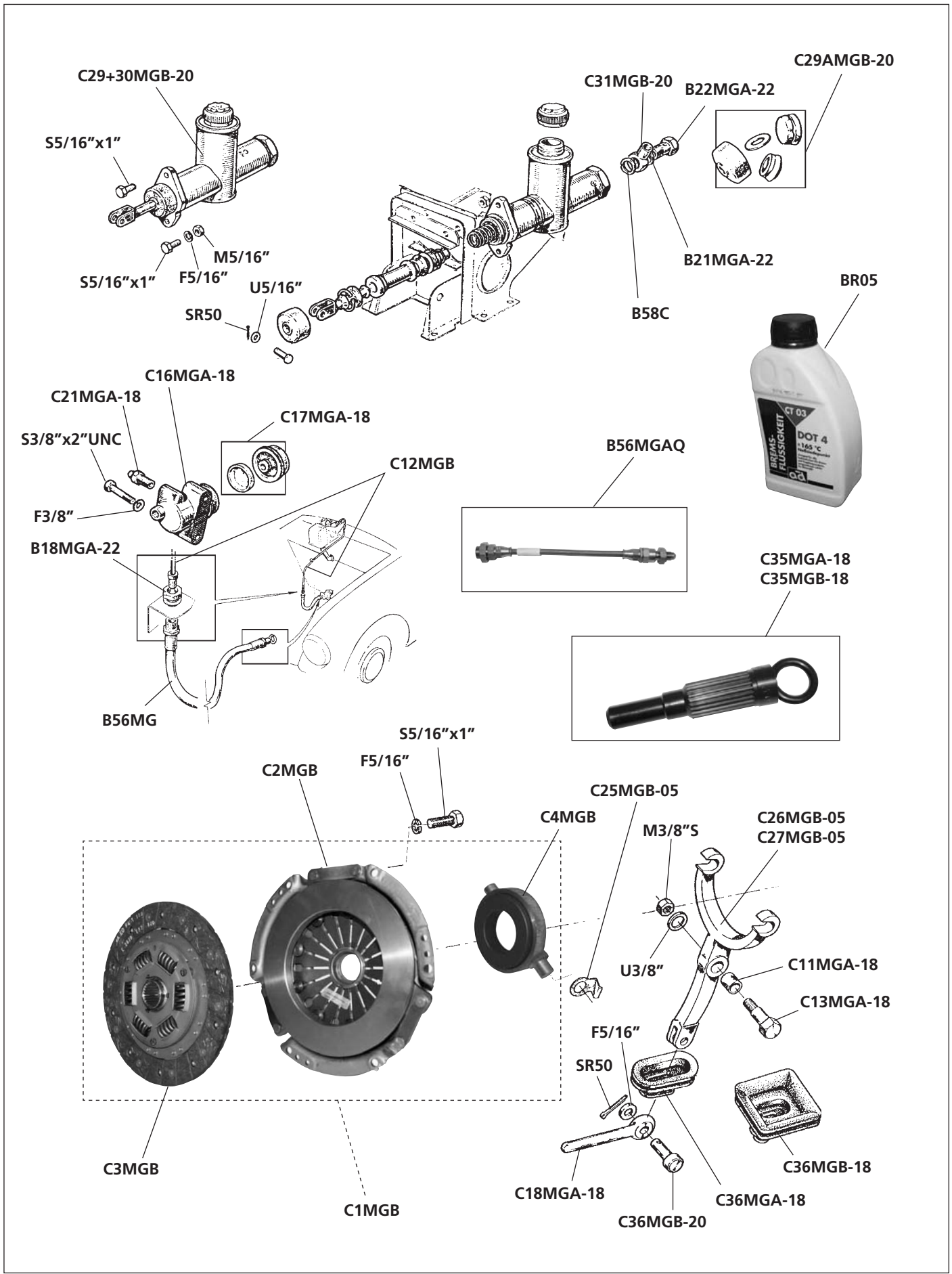

3-Synchro ohne Overdrive

3-Synchro no overdrive

No.	Bezeichnung	Description	Anzahl/Qty.
G01MGB	AT-Getriebe ohne Overdrive 3-Synchro	Exchange gearbox 3-synchro, no overdrive	1
G02MGA-19	Simmerring Getriebe vorne	Front oil seal gearbox	1
G02MGB-08	Schalthebel 3-Synchro ohne Overdrive	Change speed lever 3-synchro w/o overdrive	1
G04MGA-19	Ölablassschraube Getriebe	Plug gearbox filler/drain	1
D04MGA-26	Entlüftung Achse +Getriebe	Breather axle +gearbox	1
G05MGA-19	Gangrad 1.Gang 3-Syncro Aussenteil	Gear 1st speed 3-Syncro outer part	1
G06MGA-19	Synchroring 2.Gang Messing	Baulk ring 2nd gear brass	1
G07MGA-19	Synchroring 2.Gang Stahl	Baulk ring 2nd gear steel	1
G08MGA-19	Synchroring 3. + 4. Gang Messing	Baulk ring 3rd + 4th gear brass	2
G08MGB-08	Tachoantrieb 3-Synchro	Speedo pinion 3-synchro	1
G09MGB-08	Dichtring Tachoantrieb	Seal pinion	1
G09AMGB-08	Dichtung Tachoantrieb	Gasket speedo pinion	1
G09MGA-19	Buchse 3.Gang	Bush 3rd speed gear	1
G09MGB-08	Dichtung Tachoantrieb	Seal speedo pinion	1
G11MGA-19	Synchroteil 3. +4.Gang 3-Synchro	Synchronizer 3rd +4th (3-synchro)	1
G12MGA-19	Buchse 2.Gang	Bush 2nd gear	1
G13MGA-19	Gangrad 2.Gang	Gear 2nd speed	1
G13MGB-08	Sicherungsring	Sicherungsring	1
G13SPT	Lager Getriebehals 3-Synchro	Bearing gearbox extension 3-synchro	1
G14MGA-19	Lagernadel	Needle roller	18
G15MGA-19	Lager Getriebe-Eingangswelle	Bearing gearbox input shaft 3-synchro	1
G16MGA-19	Federscheibe	Spring washer	1
G17MGA-19	Sicherung-Scheibe	Lock washer	1
G18MGA-19	Mutter, Welle 1.Gang	Nut - 1st motion shaft	1
G19MGA-19	Vorgelegewelle bis 18GB. 74719 (16.5 mm)	Layshaft up to 18GB. 74719 (16.5 mm)	1
G20MGA-19	Vorgelege bis 18GB 74719 (16.4 mm)	Laygear up to 18GB 74719 (16.4 mm)	1
G21MGA-19	Nadellager Vorgelegewelle	Needle bearing countershaft (16.5mm)	1
G22MGA-19	Sprengring Vorgelegewelle	Circlip countershaft	1
G23MGA-19	Anlaufscheibe Getriebelager vorne bis 18GB (62-64)	Thrust washer gearbox bearing front up to 18GB (62-64)	1
G24AMGA-19	Anlaufscheibe Vorgelege hinten bis 18GB (62-64)	Thrust washer countershaft rear up to 18GB (62-64)	1
G29AMGB-08	Ausgleichscheibe .004"	Shim adjusting .004"	A/R
G29MGA-19	Simmerring Getriebe 3-Synchro hinten	Oil seal gearbox 3-synchro rear	1
G29MGB-08	Ausgleichscheibe .002"	Shim adjusting .002"	A/R
G31MGA-19	Sicherungsclip Schalthebel	Circlip gear lever	1
G32AMGB-08	Getriebe-Eingangswelle bis 18GB. (62-64)	Gearbox constant pinion shaft up to 18GB. (62-64)	1
G32MGA-19	Federdeckel Schalthebel	Spring cover gear lever	1
G32MGB-08	Getriebe-Eingangswelle ab 18GB. (65-67)	Gearbox constant pinion shaft from 18GB. (65-67)	1
G33MGA-19	Feder Schalthebel	Spring change speed lever	1
S34MGA-19	Schaltknopf	Gear lever knob	1
G38AMGB-08	Vorgelege ab 18GB 74720 (17 mm)	Laygear MGB from 18GB 74720 (17mm)	1
G40AMGB-19	Anlaufscheibe Getriebelager vorne ab 18GB (65-67)	Thrust washer gearbox bearing front from 18GB (65-67)	1
G41MGA-19	Rückwärtsgangrad	Reverse gear	1
G41MGB-08	Distanz-Hülse Vorgelege bis 18GB 74719	Spacing tube countershaft up to 18GB74719	1
G44MGB-08	Distanz-Hülse Vorgelege ab 18GB.74720	Spacing tube countershaft from 18GB.74720	1
G45MGA-19	Buchse Schaltknüppel	Bush gear lever	1
G46MGB-08	Lager Vorgelegewelle (17 mm) ab 18GB (65-67)	Bearing layshaft (17 mm) from 18GB (65-67)	1
G47MGB-08	Dichtung Deckel oben	Gasket top cover	1
G49MGB-08	Hauptwelle Getriebe 3. Gang	Mainshaft gearbox 3-Speed	1
G50MGB-08	Dichtung Getriebedeckel vorne	Gasket gearbox cover front	1
G51MGB-08	Dichtung Getriebedeckel seitlich	Gasket gearbox cover side	1
G51MGA-19	Welle Rückwärtsgang	Shaft reverse gear	1
G52MGB-08	Dichtung Schaltdeckel	Gasket remote	1
G53MGA-19	Ausgleichscheibe 0.157"	Shim adjusting 0.157"	A/R
G53AMGA-19	Ausgleichscheibe 0.159"	Shim adjusting 0.159"	A/R
G53BMGA-19	Ausgleichscheibe 0.161"	Shim adjusting 0.161"	A/R
G53MGB-08	Dichtung Getriebehals	Gasket	1
G54MGA-19	Anlaufscheibe	Thrust washer	1
G55MGA-19	Anlaufscheibe hinten	Thrust washer rear	1
G57MGA-19	Kugellager Hauptwelle 3-Synchro - bitte Größe angeben	Roller bearing mainshaft 3-synchro - please refer dimension	2
G58MGB-...	Anlaufscheibe Vorgelege hinten ab 18GB (65-67) - bitte Größe angeben	Thrust washer layshaft rear from 18GB (65-67) - please refer size	1
E107SPT	Schalter auf Getriebedeckel (Rückfahrshalter)	Switch on gearbox cover	1
GE	Hypoid Getriebe/Differentialöl SAE80W90, pro Liter	Hypoid Gearbox/Differential oil SAE80W90, per liter	A/R

3-Synchro ohne / no Overdrive

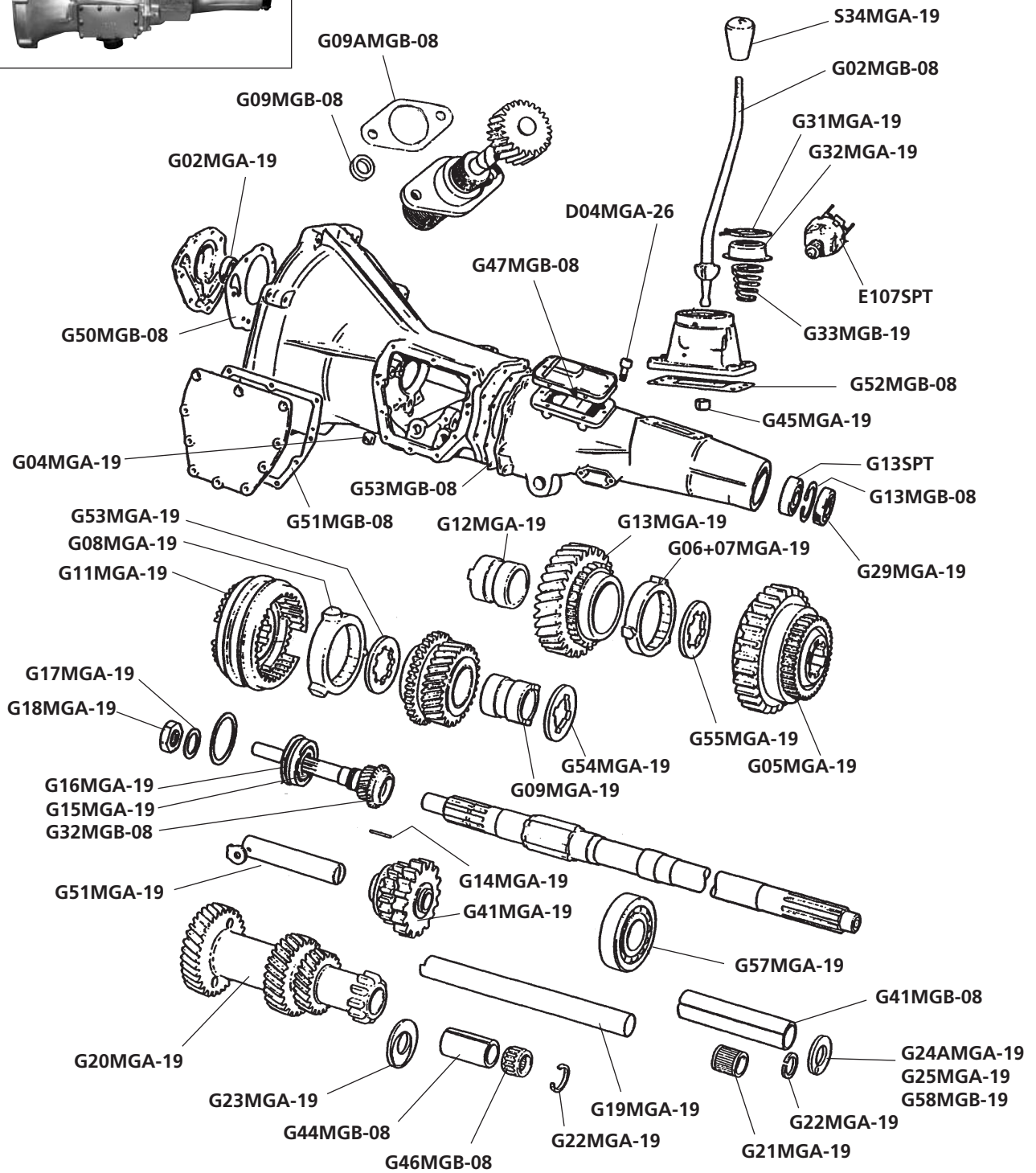
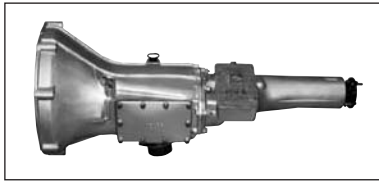

Hinweis 
Note:

Beachten Sie bitte die Hinweise zu den Austauschgetrieben auf Seite 169!

Please refer to our notes "Exchange Parts" on page 169!



3-Synchro mit Overdrive

3-Synchro with overdrive

No.	Bezeichnung	Description	Anzahl/Qty.
G02MGB	AT-Getriebe für Overdrive 3-Synchro	Exchange gearbox 3-synchro, for overdrive	1
G02MGA-19	Simmerring Getriebe	Oil seal gearbox	1
G02MGB-09	Schalthebel 3-Synchro Overdrive	Change speed lever 3-synchro overdrive	1
G04MGA-19	Ölablassschraube Getriebe	Plug gearbox filler/drain	1
D04MGA-26	Entlüftung Achse +Getriebe	Breather axle +gearbox	1/1
G05MGB-09	Feder Schalthebel	Spring change speed lever	1
W8	Umlenkgetriebe Tachowelle	Speedo angle drive	1
G08MGB-09	Fiberscheibe	Washer (fibre)	1
G11AMGB-09	Umrandung Schutzkappe	Gaiter surrounding	1
G11MGB-09	Schalthebelmanschette 3-Synchro	Gear lever gaiter 3-synchro	1
G18MGB-09	Filter Overdrive 3-Synchro	Filter overdrive 3-synchro	1
G26MGB-09	Dichtung Magnetschalter/Overdrive	Gasket	1
G28MGB-08	Dichtung Schaltdeckel	Gasket remote	1
G29MGB-09	Lager Tachoritzel 3-Synchro +Overdrive	Bearing speedo pinion 3-synchro +overdrive	1
G31MGA-19	Sicherungsclip Schalthebel	Circlip gear lever	1
G32MGA-19	Federdeckel Schalthebel	Spring cover gear lever	1
S34MGA-19	Schaltknopf	Gear lever knob	1
G45MGA-19	Buchse Schaltknüppel	Bush gear lever	1
G50MGB-08	Dichtung Getriebedeckel vorne	Gasket gearbox cover front	1
G51MGB-08	Dichtung Getriebedeckel seitlich	Gasket gearbox cover side	1
G53MGB-08	Dichtung Overdrive-Adapterplatte/Getriebe	Gasket overdrive adaptor plate/casing	1
G100SPT	Flanschdichtung Overdrive	Gasket overdrive	1
G101SPT	Dichtung Magnetschalter-Platte	Gasket solenoid plate	1
G102SPT	Dichtung Filter Overdrive	Gasket overdrive filter	1
G103SPT	Simmerring Overdrive hinten	Oil seal overdrive rear	1
G106ASPT	Magnetschalter A-Overdrive	Solenoid A-overdrive	1
E107SPT	Schalter Overdrive/Rückfahrcheinwerfer auf Getriebedeckel	Switch overdrive/reverse light on gearbox cover	1/1
G110SPT	Tachuantriebsritzel	Speedometer pinion	1
GE	Hypoid Getriebe/Differentialöl SAE80W90, pro Liter	Hypoid gearbox/differential oil SAE80W90, per liter	A/R

Hinweis
Note:

Beachten Sie bitte die Hinweise zu den Austauschgetrieben auf Seite 169!

Please refer to our notes "Exchange Parts" on page 169!

3-Synchro mit / with Overdrive

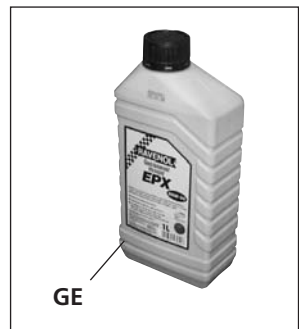
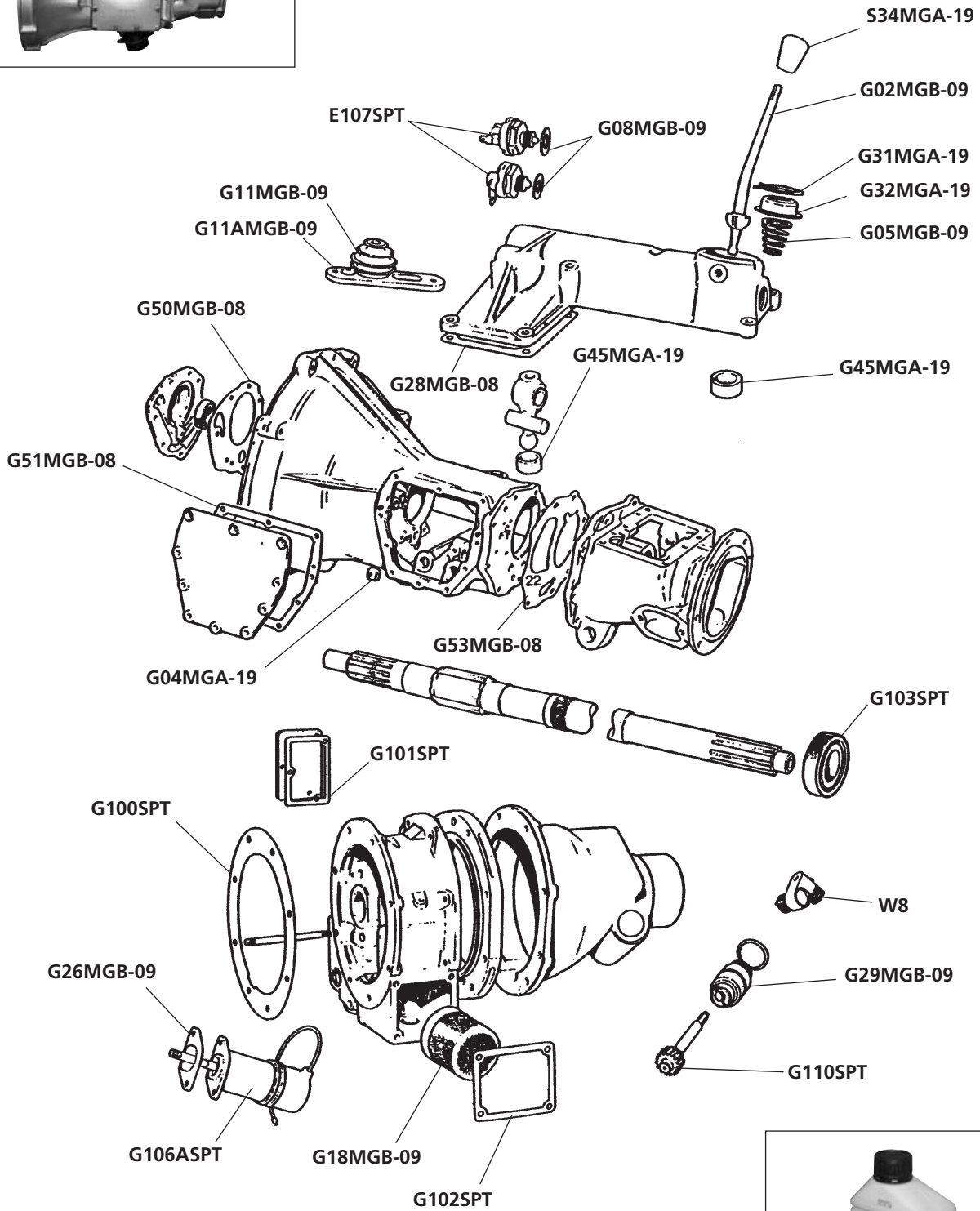
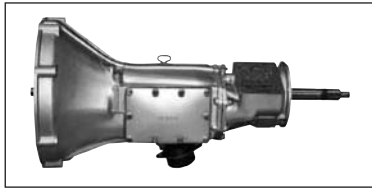

4-Synchro ohne Overdrive

4-Synchro no overdrive

No.	Bezeichnung	Description	Anzahl/Qty.
G04AMGB-10	AT-Getriebe 4-Synchro ohne Overdrive	Exchange gearbox 4-synchro, no overdrive	1
G02MGA-19	Simmerring Getriebe vorne	Front oil seal gearbox	1
S02MGB-10	Schaltnauf rund (67-72)	Gear lever knob round (67-72)	1
G03MGB-10	Schalthebel (67-76)	Change speed lever (67-76)	1
D04MGA-26	Entlüftung Achse +Getriebe	Breather axle +gearbox	1
G04MGA-19	Ölablaß/Einfüllschraube	Drain plug	1
G06MGB-10	Schalthebelmanschette Gummi	Gear lever gaiter	1
G07BMGB-10	Haltering Schalthebelmanschette chrom	Retainer ring gear lever grommet chrome	1
G07CMGB-10	Schraube Schalthebelring lang chrom	Screw gear lever grommet long	4
G08MGB-09	Fiberscheibe	Washer (fibre)	A/R
G08MGB-10	Buchse Schaltgestänge	Bush selector	1
W8	Winkelantrieb	Speedo angle drive	1
G09MGB-08	Dichtring Tachoantrieb	Seal speedo pinion	1
G09AMGB-08	Dichtung Tachoantrieb	Gasket speedo pinion	1
G13MGB-10	Mutter (Linksgewinde)	Nut, left hand thread	1
G14MGB-10	Sicherung-Scheibe	Lock washer	1
G15AMGB-10	Ausgleichscheibe (0.005")	Shim adjusting (0.005")	A/R
G15MGB-10	Ausgleichscheibe (0.002")	Shim adjusting (0.002")	A/R
G17MGB-10	Lager Getriebe-Eingangswelle	Bearing constant pinion shaft	1
G19MGB-10	Nadellager	Needle bearing	1
G20MGB-09	Umlenkgetriebe Tachowelle	Speedo angle drive	1
G25MGB-10	Sicherung-Scheibe	Lock washer	1
G27MGB-10	Lager Hauptwelle vorne	Bearing 3rd motion shaft front	1
G29BMGB-10	Tachuantriebsrad 9 Zähne (Gummistoßstangen-Modell)	Speedo gear 9 teeth	1
HA32MGA-25	Bolzen Kardanwelle MGB früh	Bolt propshaft MGB early	4
HA33MGA-25	Selbstsichernde Mutter UNF 5/16 x 5/16" zu HA32MGA-25	Nut UNF 5/16 x 5/16" to no HA32MGA-25	4
G33MGB-10	Simmering Getriebe hinten	Oil seal drive flange	1
G34MGB-10	Sicherung-Scheibe	Lock washer	1
G35MGB-10	Mutter Flansch am Getriebe	Nut flange to gearbox	1
G36MGB-10	Synchroring (Metall)	Baulk ring (metal)	2
G39MGB-10	Gangrad 3.Gang	Gear 3th speed	1
G41MGB-10	Klemmring	Interlocking washer	1
G42MGB-10	Gangrad 2.Gang mit Buchse	Gear 2nd speed with bush	1
G44MGB-10	Ausgleichscheibe	Shim adjusting	1
i44MGB	Schalthebelmanschette 4-Synchro Vinyl schwarz	Gear lever gaiter 4-synchro vinyl black	1
i44MGBL	Schalthebelmanschette 4-Synchro Leder schwarz	Gear lever gaiter 4-synchro leather black	1
G45MGA-19	Buchse Schaltknüppel	Bush gear lever	1
G45MGA-19	Buchse Schalthebel unten	Bush gear lever lower	1
G45MGB-10	Synchroring (Metall)	Baulk ring (metal)	2
G46MGB-10	Synchroteil 1. +2.Gang	Synchro 1st & 2nd	1
G47AMGB-10	Gangrad 1.Gang mit Buchse	Gear 1st speed with bush	1
G49MGB-10	Rückwärtsgangrad auf Hauptwelle	Reverse gear	1
G50MGB-10	Rückwärtsgangrad	Reverse gear	1
G54MGB-10	Federscheibe	Spring washer	2
G55MGB-10	Vorgelege	Laygear	1
G56MGB-10	Vorgelegewelle 4-Synchro	Layshaft 4-Synchro	1
G57MGB-10	Distanz-Hülse	Spacing tube	1
G58MGB-10	Nadellager Vorgelegewelle 4-Synchro	Needle bearing 4-Synchro	2
G59MGB-10	Anlaufscheibe hinten ab 74 (0.133-5") (Gummistoßstange)	Thrust washer rear 74 on (0.133-5") (Rubber bumper)	1
G61MGB-10	Dichtung Getriebedeckel vorne	Gasket gearbox cover front	1
G62MGB-10	Dichtung Getriebedeckel seitlich	Gasket gearbox cover side	1
G63MGB-10	Dichtung	Seal	1
G64MGB-10	Dichtung Schaltdeckel	Gasket gearbox cover	1
G65MGB-10	Schraube	Screw	3
E107SPT	Schalter auf Getriebedeckel (Rückfahrshalter)	Switch on gearbox cover	1
GE	Hypoid Getriebe/Differentialöl SAE80W90, pro Liter	Hypoid gearbox/differential oil SAE80W90, per liter	A/R

Hinweis
Note:

Beachten Sie bitte die Hinweise zu den Austauschgetrieben auf Seite 169!

Please refer to our notes "Exchange Parts" on page 169!

4-Synchro ohne / no Overdrive

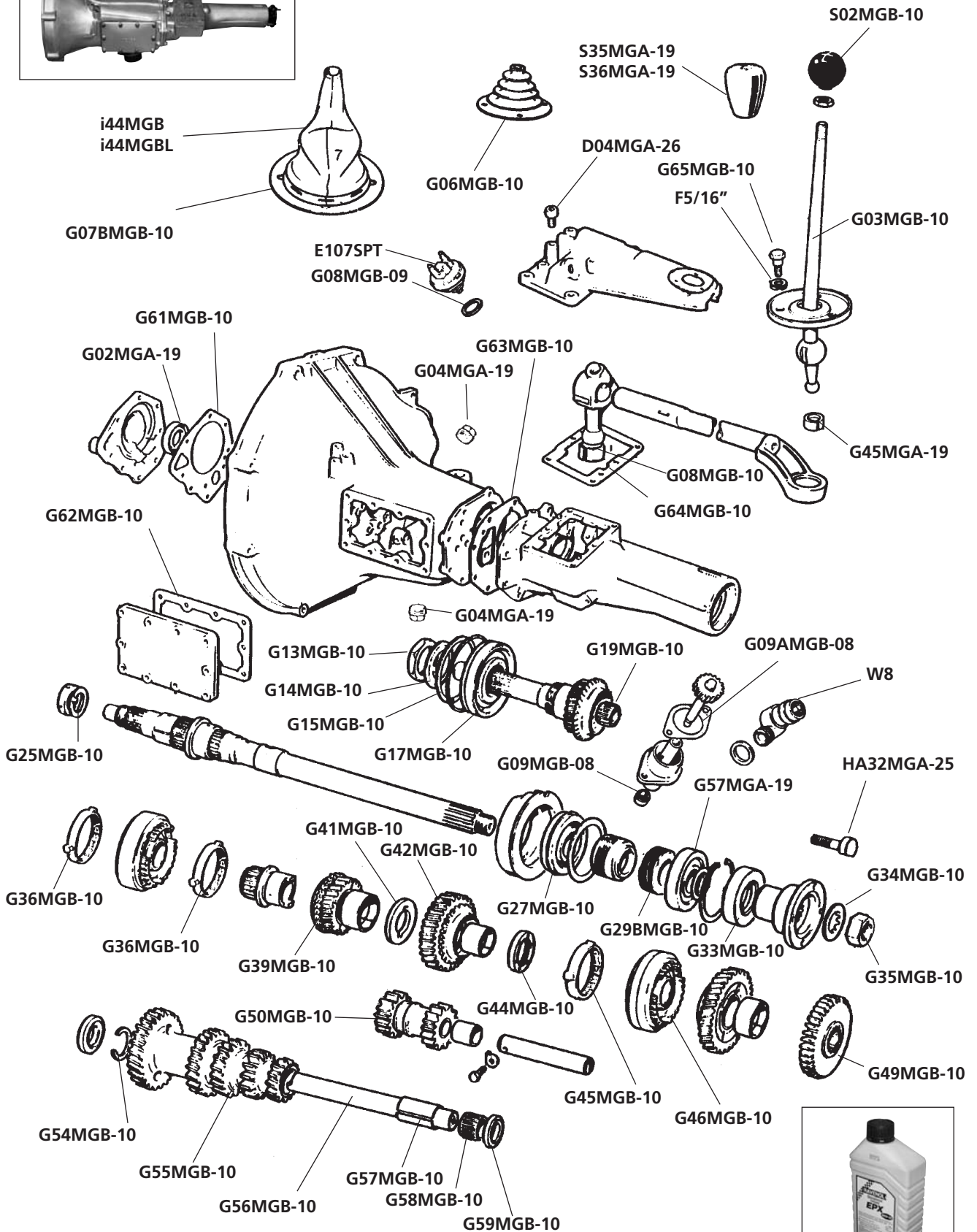
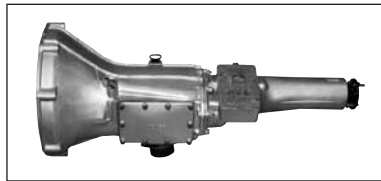

4-Synchro mit Overdrive

4-Synchro with overdrive

No.	Bezeichnung	Description	Anzahl/Qty.
G04MGB-10/CR	AT-Getriebe 4-Synchro für Overdrive bis 1974, mit Ölpeilstab	Exchange gearbox 4-synchro, for overdrive to 1974	1
G04MGB-10/RB	AT-Getriebe 4-Synchro für Overdrive ab 1975, mit Ölstands-kontrollschraube	Exchange gearbox 4-synchro, for overdrive from 1975	1
G02MGA-19	Simmerring Getriebe vorne	Front oil seal gearbox	1
S02MGB-10	Schaltnauf rund	Gear lever knob round	1
G03MGB-10	Schalthebel	Change speed lever	1
D04MGA-26	Entlüftung Achse +Getriebe	Breather axle +gearbox	1
G06MGB-10	Schalthebelmanschette Gummi	Gear lever gaiter	1
G07BMGB-10	Haltering Schalthebelmanschette chrom	Retainer ring gear lever grommet chrome	1
G07CMGB-10	Schraube Schalthebelring lang chrom	Screw gear lever grommet long chrome	4
G08MGB-09	Fiberscheibe	Washer (fibre)	1
G08MGB-10	Buchse Schaltgestänge	Bush selector	1
G11MGB-11	Schalthebel	Change speed lever	1
G24MGB-11	Getriebe-Hauptwelle	Third motion shaft	1
G26MGB-11	Mutter Schaltknopf UNC 3/8"	Gear knob lock nut UNC 3/8"	1
G27MGB-11	Lager Hauptwelle 4-Synchro Overdrive	Bearing 3rd motion shaft 4-synchro overdrive	1
G33MGB-10	Simmerring Getriebe hinten	Oil seal drive flange	1
S35MGA-19	Schaltnauf Holz	Gear lever knob, wooden	1
S36MGA-19	Schaltnauf Leder	Gear lever knob, leather	1
i44MGB	Schalthebelmanschette 4-Synchro Vinyl schwarz	Gear lever gaiter 4-synchro vinyl black	1
i44MGBL	Schalthebelmanschette 4-Synchro Leder schwarz	Gear lever gaiter 4-synchro leather black	1
G45MGA-19	Buchse Schaltknüppel	Bush gear lever	1
G65MGB-10	Schraube	Screw	3
E107SPT	Schalter auf Getriebedeckel	Switch on gearbox cover	1
GE	Hypoid Getriebe/Differentialöl SAE80W90, pro Liter	Hypoid gearbox/differential oil SAE80W90, per liter	A/R

50 Schaltgestänge / Gear Change Selector Rods 4-Synchro

No.	Bezeichnung/ Description	Anzahl/Qty.
G08MGB-10	Buchse Schaltgestänge / Bush selector	1
G28MGB-11	Wahlhebel 1. + 2. Gang / Selector 1st + 2nd gear	1
G29MGB-11	Wahlhebel 3. + 4. Gang / Selector 3rd + 4th gear	1
G30MGB-11	Schaltwelle Rückwärtsgang / Selector rod reverse	1
G31MGB-11	Schaltgabel 1. + 2. Gang / Fork 1st + 2nd gear	1
G32MGB-11	Schaltgabel 3. + 4. Gang / Fork 3rd + 4th gear	1
G33MGB-11	Feder Hebel Rückwärtsgang / Spring reverse selector	1
G35MGB-11	Wahlhebel / Selector lever	1
G45MGA-19	Buchse Schaltknüppel / Bush gear lever	1
G49MGA-19	Feder / Spring	1

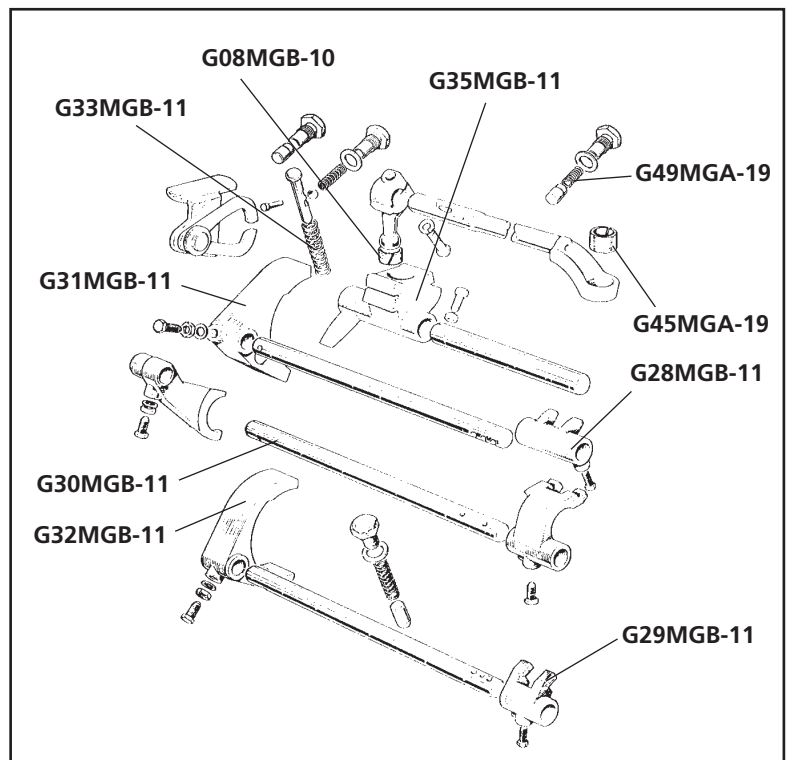

4-Synchro mit / with Overdrive

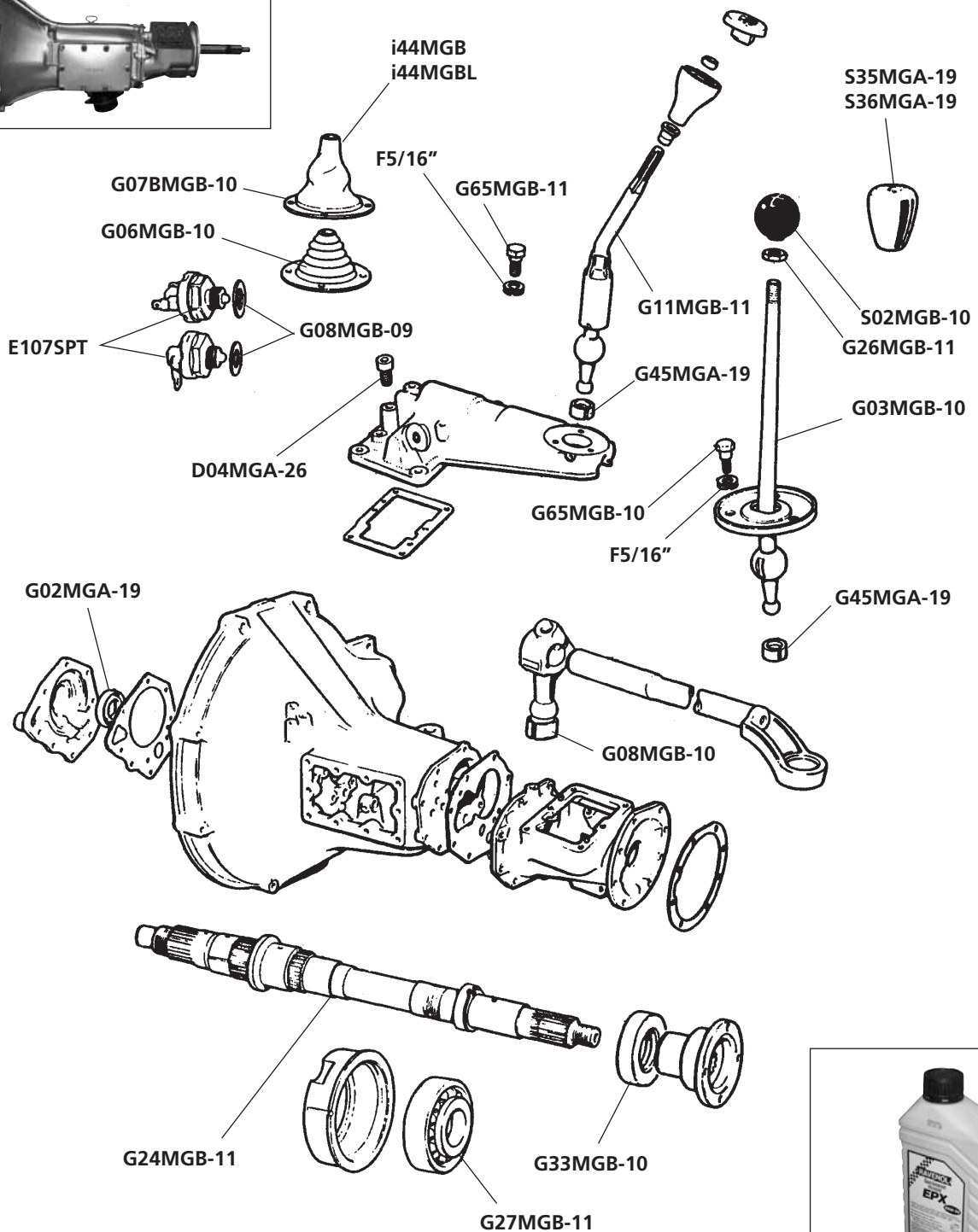
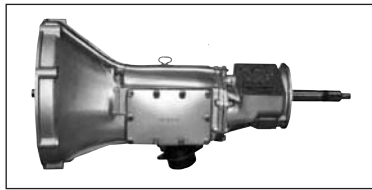

Hinweis 
Note:

Beachten Sie bitte die Hinweise zu den Austauschgetrieben auf Seite 169!

Please refer to our notes "Exchange Parts" on page 169!



OD-Schalter, Relais, Unterdrucksteuerung

Overdrive Controls, Electrics

No.	Bezeichnung	Description	Anzahl/Qty.
E40MGB	OD-Relais	Relais Overdrive	1
E129MGB	OD-Schalter in Armaturenbrett abgewinkelt	Switch, overdrive straight	1
E143MGB	OD-Schalter in Armaturenbrett gerade	Switch, overdrive angled	1
E145ASPT	OD-Schalter in Schaltknopf ab 1976	Switch, overdrive gear knob from 1976	1
E145BMGB	OD-Schalterabdeckung auf Schaltknopf ab 1976	Plate overdrive switch from 1976	1
E145CMGB	Schaltknopf OD-Schalter	Gear knob overdrive	1
E145DMGB	Mutter Chrom	Nut chrome	1
E145EMGB	Sicherungsmutter Schaltknopf OD	Knob lock nut	1
G225MGB	Anschlußstutzen Unterdruckschlauch	Adaptor manifold	1
G226MGB	Unterdruckschlauch	Hose, vaccum	1
G227MGB	Unterdruckschalter Overdrive	Switch, overdrive vaccum	1

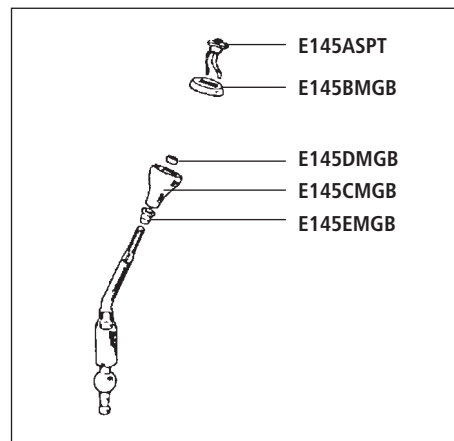
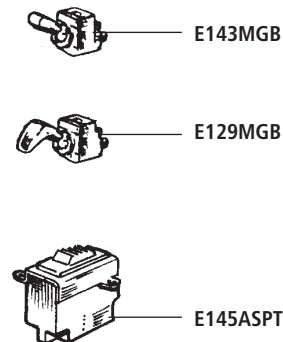
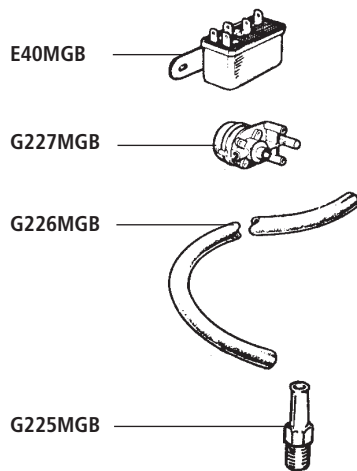

OD-Schalter, Relais, Unterdrucksteuerung

Overdrive Controls, Electrics

No.	Bezeichnung	Description	Anzahl/Qty.
G01MGB-06	AT-Overdrive 3-Synchro D-Typ	Overdrive 3-synchro D-type, exchange	1
W8	Winkelantrieb Tachowelle	Speedo drive to speedo cable	1
G29MGB-09	Lager Tachoritzel	Bearing, speedometer	1
D38SPTMK4	Lager, Overdrive Ausgang	Bearing outlet	1
D48TR6	Lager, Overdrive Mitte	Central Bearing	1
SR52	Splint 3.2 mm	Split pin 3.2 mm	1
G100SPT	Overdrive - Flanschdichtung	Gasket - flange, (front)	1
G101SPT	Overdrive - Dichtung für Magnetschalter	Gasket - side, for magnetic switch	1
G101VO	Dichtring für Tachoantrieb	Gasket - Speedometer	1
G102SPT	Overdrive - Dichtung seitlich (Ölfilter)	Gasket, side, for oil filter	1
G103SPT	Simmering	Radial oil seal	1
G105SPT	Lager Overdrive vorne	Front bearing	1
G106ASPT	Magnetschalter Overdrive	Magnetic switch - Overdrive	1
G107SPT	O-Ring Druckkolben	O- Gasket piston	1
G108SPT	O-Ring	O- Gasket	1
G109SPT	AT-Kupplung	Clutch, exchange	1
G110SPT	Tachoantriebsritzel 16 Zähne	Speedo pinion (with 16 teeth)	1
G111SPT	Feder auf Hauptwelle	Spring	1
GE	Hypoid Getriebe-/ Differentialöl SAE80W90, pro Liter	Hypoid Gearbox-/ Differential oil SAE80W90, per liter	A/R

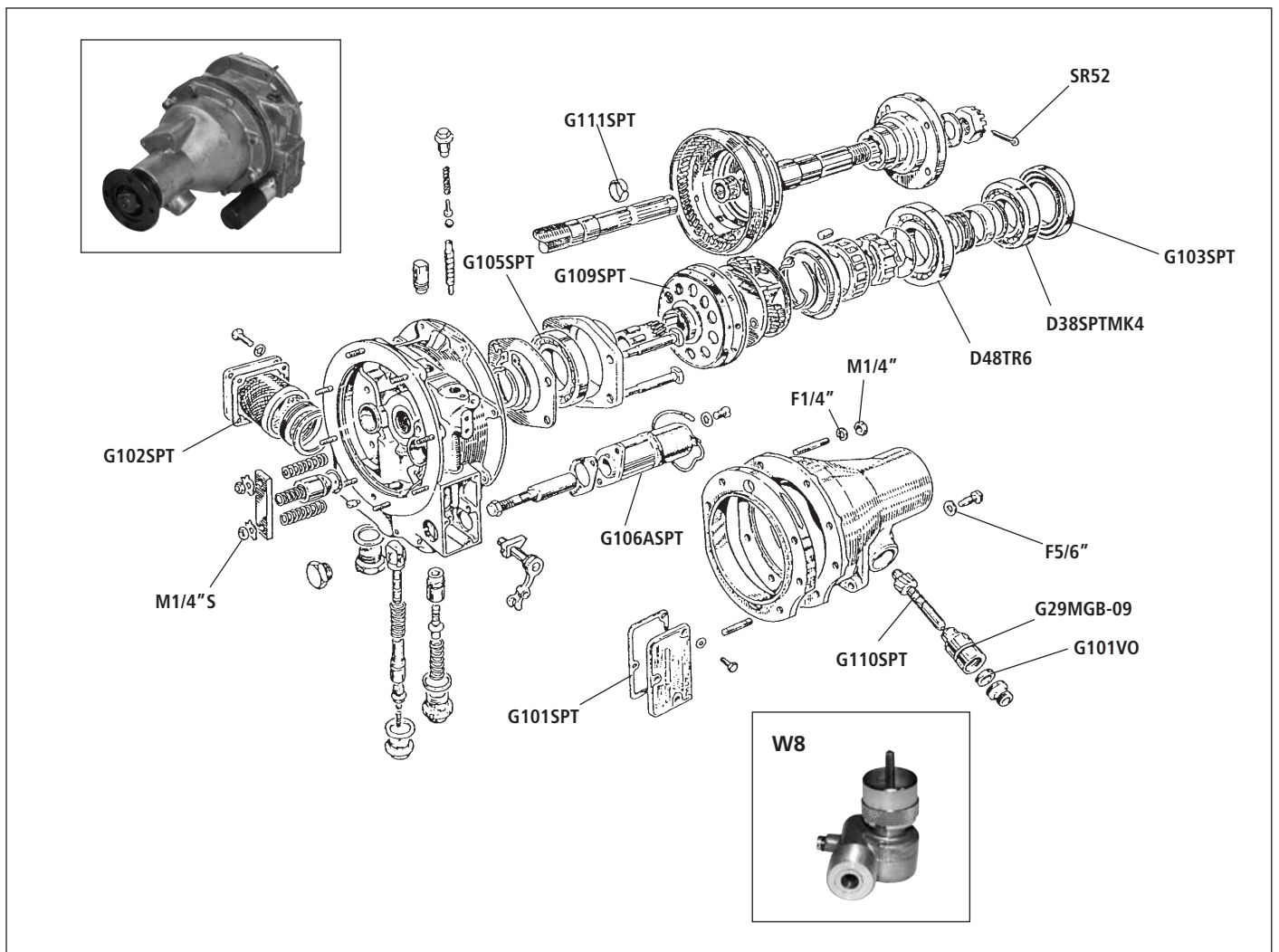

Hinweis  **Note:**



Beachten Sie bitte die Hinweise zu den Austausch-Overdrive auf Seite 169!

Please refer to our notes "Exchange Parts" on page 169!

No.	Bezeichnung	Description	Anzahl/Qty.
G05MGB	AT-Overdrive 4-Synchro bis 75 (Chromstoßstangenmodell)	Exch. overdrive 4-synchro up to 75 (Chrome bumper model)	1
G05AMGB	AT-Overdrive 4-Synchro ab 75 (Gummistoßstangenmodell)	Exch. overdrive 4-synchro from 75 (Rubber bumper model)	1
G8TR	Lager Overdrive hinten	Bearing overdrive rear	1
G66TR	Simmerring hinten	Oil seal extension	1
G100SPT	Dichtung	Gasket overdrive	1
G101TR	Lager Kupplungsdruckring	Bearing clutch thrust ring	1
G108TR	O-Ring	O-ring	2
G200MGB	Filter/Dichtung	Filter +gasket overdrive	1
G202MGB	Dichtung Magnetschalter	Gasket solenoid	1
G203SPT	Lager Overdrive-Kupplung	Bearing overdrive clutch	1
G205SPT	O-Ring Kolben	O-ring overdrive piston	1
G205MGB	O-Ring Magnetschalter klein	O-ring overdrive solenoid small	1
G208MGB	AT-Overdrive-Kupplung	Exch. overdrive clutch	1
G209MGB	Magnetschalter Overdrive LH-Typ	Solenoid overdrive LH type	1
G210MGB	Nocke Overdrive Pumpenantrieb früh (Keil Sicherung)	Cam, oil pump (key-way type pump cam early spec.)	1
G210AMGB	Nocke Overdrive Pumpenantrieb spät (Kugel Sicherung)	Cam, oil pump (with ball located pump cam late spec.)	1
G211MGB	Keil für G210MGB	Woodruff key to no. G210MGB	1
G211AMGB	Kugel für G210AMGB	Ball, locating to no. G210AMGB	1
G212MGB	Sicherungsring	Circlip	1
G215MGB	Tachoritzel 21 Zähne bis '75	Speedo pinion (21 teeth) up to '75	1
G215AMGB	Tachoritzel 20 Zähne ab '75	Speedo pinion (20 teeth) from '75 on	1
G216MGB	Führungsbuchse Tachoritzel	Bearing cage speedometer drive	1
GE	Hypoid Getriebe-/ Differentialöl SAE80W90, pro Liter	Hypoid Gearbox-/ Differential oil SAE80W90, per liter	A/R

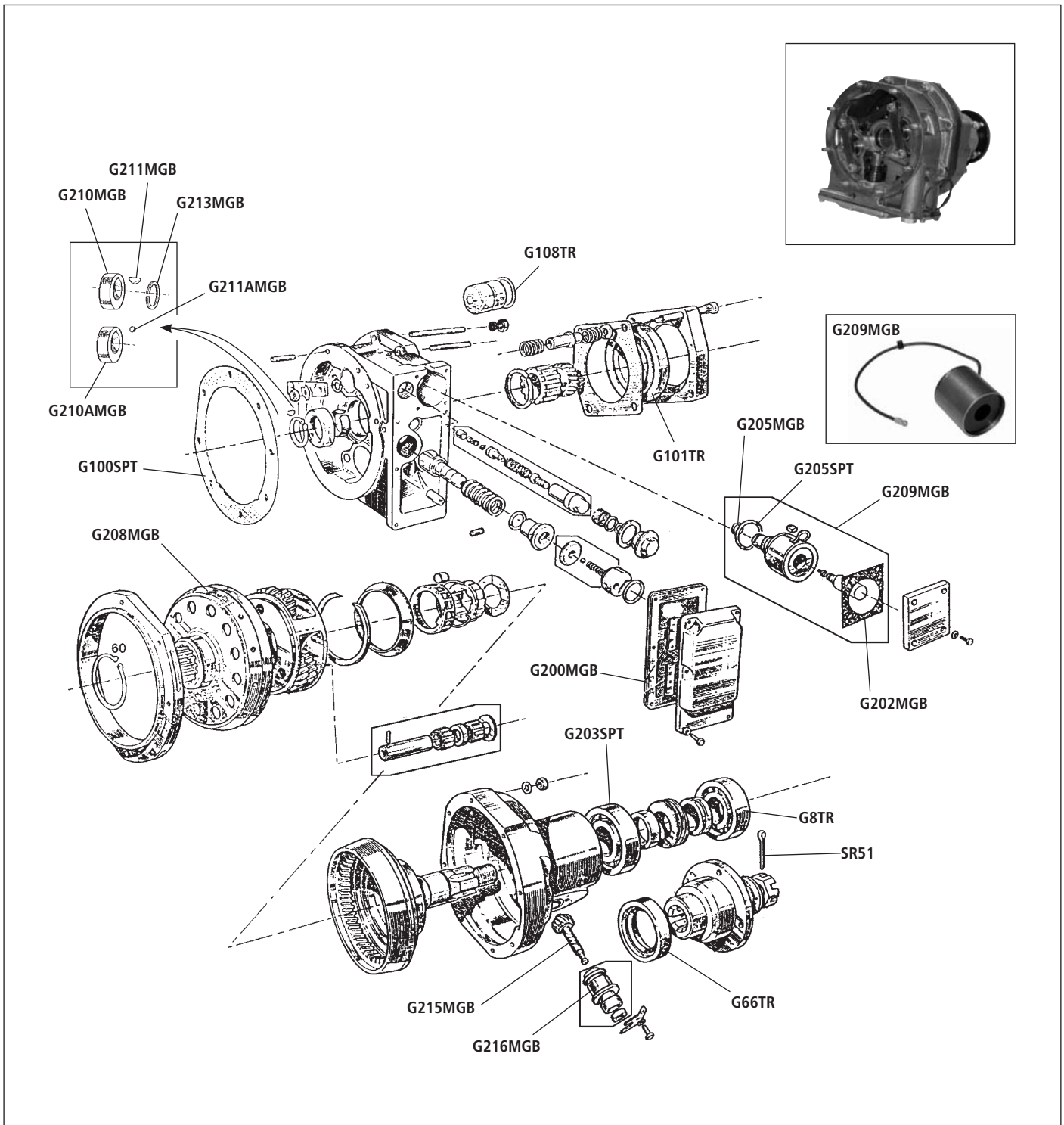

Hinweis
Note:



Beachten Sie bitte die Hinweise zu den Austausch-Overdrive auf Seite 169!

Please refer to our notes "Exchange Parts" on page 169!

Kardanwelle		Propshaft	
No.	Bezeichnung	Description	Anzahl/Qty.
HA32MGA-25	Schraube Kardanwelle	Bolt propshaft	8
HA36MGA-25	Schmiernippel	Grease nipple	1
D54ASPTMK3	Flansch	Flange	2
D55SPT	Kreuzgelenk	Universal joint	2
D55ASPT	Kreuzgelenk mit Schmiernippel	Universal joint with grease nipple	2
HA60MGB	Kardanwelle: Overdrive 3-Synchro Banjo-Achse 62-66 (790 mm lang) / + Normalgetriebe Tube-Axle ab 1966 / + alle 4-Synchro Modelle ab 1968 (Stand. + Overdrive)	Propshaft: Overdrive 3-synchro Banjo-axle 62-66 (790 mm long) / + Standard gearbox Tube-axle from 1966 / + all 4-synchro models from 1968 (Stand. + Overdrive)	1
HA61MGB	Kardanwelle Normalgetriebe 3-Synchro Banjo-Achse 62-66 (762 mm lang)	Propshaft standard gearbox 3-Synchro Banjo-axle 62-66 (762 mm long)	1
HA62MGB	Kardanwelle Overdrive 3-Synchro Tube-Axle 65-68 (812 mm lang)	Propshaft Overdrive 3-synchro Tube-axle 65-68 (812 mm long)	1
Blattfeder		Road spring	
HA100MGB	Blattfeder Roadster 62-74 (Chromstoßstange)	Rear spring Roadster 62-74 (Chrome bumper)	2
HA100AMGB	Blattfeder Competition **) Roadster 62-74 (Chromstoßst.)	Rear spring Competition **) Roadster 62-74 (Chrome bumper)	2
HA101MGB	Blattfeder GT 65-74 (Chromstoßstange)	Rear spring GT 65-74 (Chrome bumper)	2
HA101AMGB	Blattfeder Competition **) GT 65-74 (Chromstoßstange)	Rear spring Competition **) GT 65-74 (Chrome bumper)	2
HA102MGB	Blattfeder Roadster ab GHN5 386796 ab 75 (Gummistoßst.)	Rear spring Roadst. from GHN5 386796 from 75 (Rubber b.)	2
HA102AMGB	Blattfeder Competition **) Roadster ab GHN5 386796 ab 75 (Gummistoßstange)	Rear spring Competition **) Roadster from GHN5 386796 from 75 (Rubber bumper)	2
HA103MGB	Blattfeder GT ab 75 (Gummistoßstange)	Rear spring GT from 75 (Rubber bumper)	2
HA103AMGB	Blattfeder Competition **) Roadster 62-74 (Gummistoßstange)	Rear spring Competition **) Roadster 62-74 (Rubber bumper)	2
HA01MGB-19	Hebelstoßdämpfer *)	Shocker *)	2
HA01MGB-COMPL/R	Hebelstoßdämpfer Competition + 30% härter *)	Shocker Competition + 30% *)	2
HA06AMGB-19	Stoßdämpfer Verbindungsarm (Gummistoßstange)	Shocker link up (Rubber bumper)	2
HA06MGB-19	Stoßdämpfer Verbindungsarm (Chromstoßstange)	Shocker link (Chrome bumper)	2
HA07AMGB-19	Achsfangband Hinterachse (Gummistoßstange)	Rebound strap rear axle from 75 (Rubber bumper)	2
HA07MGB-19	Achsfangband Hinterachse (Chromstoßstange)	Rebound strap rear axle up to 75 (Chrome bumper)	2
HA08MGB-19	Distanz-Hülse Achsfangband	Spacing tube check strap	2
HA11MGB-19	Anschlaggummi Hinterachse	Buffer rear axle bump	2
HA12MGB-19	Anschlagplatte Banjo-Achse	Rebound pedestal banjo axle	2
HA12AMGB-19	Anschlagplatte Tube-Axle	Rebound pedestal tube axle	2
HA13MGA-25	Gummi-Auflage Blattfeder	Rubber pad leaf spring	4
HA14MGB-19	Federplatte Tube-Axle	Spring plate tube axle	4
HA14MGA-25	Federplatte Banjo-Achse	Spring plate banjo axle	4
HA15MGB-19	Stoßdämpfer Platte Tube-Axle *)	Shocker bracket tube axle *)	4
HA15MGA-25	Stoßdämpferarm Halteblech Banjo-Achse *)	Shocker bracket early banjo axle *)	4
HA17MGA-25	U-Bolzen Banjo-Achse	U-bolt banjo axle	4
HA17MGB-19	U-Bolzen Hinterachse Tube-Axle	U-bolt tube axle	2
HA18MGB-19	Silentbuchse Blattfeder hinten	Silent bush leaf spring rear	2
HA20MGB-19	Reparaturbolzen unten (muß an Hinterachsgehäuse angeschweißt werden!)	Bolt - repair kit (must be weld on the rear axle housing!)	2
HA21MGB-19	Bolzen Blattfeder Mitte	Bolt leaf spring centre	2
HA23MGA-25	Haltebügel Blattfeder hinten	Shackle plate with pins	2
HA23MGB-19	Stabilisator hinten	Anti-roll-bar rear	1
HA24MGB-19	Endstück Stabilisator	End bush anti-roll-bar	2
HA25MGB-19	Lagerbuchse Stabilisator hinten	Bearing bush anti-roll-bar rear	1
HA26MGB-19	Lagerbügel Stabilisator	Mounting strap anti-roll-bar	2
HA27MGB-19	Obere und untere Halteklemme	Bracket, upper and lower	2
HA29MGB	Umrüstsatz auf Normalstoßdämpfer (ohne Dämpfer) mit TÜV-Gutachten	Service kit - to fit standard shock absorbers (w/o absorber) - with TÜV-approval	1
HA35TR	Gummilager Blattfeder hinten	Rubber bush shackle plate	8
HA35ATR	Nylonbuchse Blattfeder als hochwertiger Ersatz für HA35TR	Nylon bush shackle plate, high performed -to replace no. HA35TR	8
HA41TR	Federaufhängung-Platte	Shackle plate	2
HA43AH	Tieferlegungssatz, Tieferlegung des Fzges. um ca. 2 cm	lowering bock kit, allows lowering of the car about 2,5 cm	1
VA80AMGB	Stoßdämpfer KONI für Umrüstsatz	KONI shock absorber for service kit	2
HM5/8"	Mutter 5/8" UNF halbe Stärke	Half nut 5/8" UNF	A/R
HSD	Hebel-Stoßdämpferöl 500 ml	Shocker absorber oil 500 ml	A/R



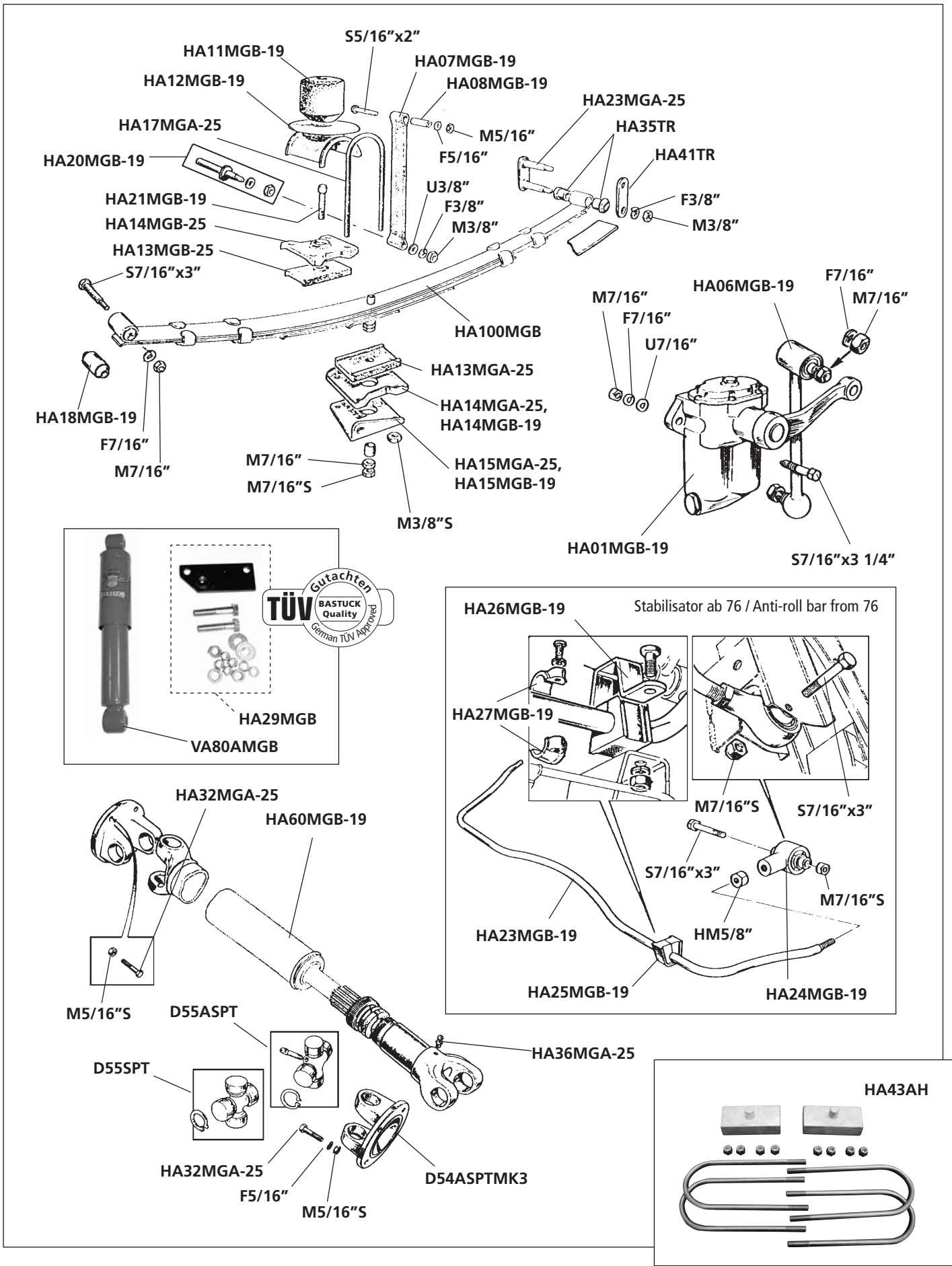

*) Links/rechts. Bitte Fahrzeugseite angeben.

*) Please refer side of the car -lh or rh

***) Blattfeder Competition = 1" tiefer

***) Rear spring Competition = 1" less of height

No.	Bezeichnung	Description	Anzahl/Qty.
D01MGA-26	Mutter Rechtsgewinde rechts	Nut (rh thread) rh	1
D01MGB/B..	AT-Differential bis 67 Übersetzung 3.7/3.9/4.1/4.3/4.55 möglich	Exchange differential up to 67 - please refer transmission: 3.7/3.9/4.1/4.3/4.55	1
D02MGA-26	Mutter Linksgewinde links	Nut lh thread	1
D02MGB-16	Steckachse Scheibenräder	Axle shaft disc wheels	2
D03MGB	Deckel Differentialgehäuse	Rear cover	1
D04AMGB-16	Speichenradnabe 12 TPI hinten rechts	Wire wheel hub 12 tpi rear rh	1
D04BMGB-16	Speichenradnabe 12 TPI hinten links	Wire wheel hub 12 tpi rear lh	1
D04CMGB-16	Speichenradnabe 8 TPI hinten rechts (64-67)	Wire wheel hub 12 tpi rear rh (64-67)	1
D04DMGB-16	Speichenradnabe 8 TPI hinten links (64-67)	Wire wheel hub 12 tpi rear lh (64-67)	1
D04MGA-26	Entlüftung Achse +Getriebe	Breather axle +gearbox	1
G04MGA-19	Öleinfüll/Ablaßstopfen	Drain plug	2
D05MGB-16	Radlagergehäuse	Hub	2
D05MGA-26	Dichtung	Seal	1
D07MGA-26	Sicherung-Scheibe	Lock washer	2
D08MGA-26	Lager Hinterachse Banjo-Achse	Bearing differential banjo axle	2
D11MGB-16	Flansch Hinterachse früh	Flange differential early	1
D12MGB-16	Radbolzen Stahlfelge	Stud steel wheel	8
D12MGA-26	Anlaufscheibe Hinterachse	Thrust washer	2
D13MGA-26	Anlaufscheibe Hinterachse	Thrust washer	2
D14MGA-26	Welle Planetenrad Banjo-Achse	Shaft pinion	1
D15MGA/3.7	Teller- und Kegelrad 3.7	Crown wheel and pinion 3.7	1
D15MGA/3.909	Teller- und Kegelrad 3.909	Crown wheel and pinion 3.909	1
D15MGA/4.3	Teller- und Kegelrad 4.3	Crown wheel and pinion 4.3	1
D15MGA/4.55	Teller- und Kegelrad 4.55	Crown wheel and pinion 4.55	1
HA20MGB-19	Reparaturbolzen unten	Bracket, check strap	2
D22MGA-26	Lager aussen - frühe Achse	Bearing outer - early differential	1
D26MGA-26	Simmerring Differential Banjo-Achse	Oil seal banjo axle	1
D30MGA-26	Mutter 3/4" UNF flach	Half nut 3/4" UNF	A/R
D33MGA-26	Steckachse Speichenräder 25 Zähne	Axle shaft wire wheels 25 teeth	2
D34MGA-26	Stopfen Speichenradachse (klein)	Core plug wire wheel hub (small)	2
D40MGA-26	Dichtung Radnabe Banjo-Achse	Gasket wheel hub banjo axle	2
D43MGA-26	O-Ring Radflansch Banjo-Achse	O-ring wheel hub banjo axle	2
D44MGA-26	Simmerring Radflansch	Oil seal axle hub	2
D45MGA-26	Radlager Hinterachse seitlich	Wheel bearing differential side	2
D46MGA-26	Distanzteil Lager Scheibenräder	Spacer bearing disc wheels	2
D53MGA-26	Planetenrad Differential	Planet gear differential	2
D90MGA	Differentialsperre *	Limited slip differential *	1
D300MGA	Schlüssel für Radflanschmutter	Rear hub nut socket	1
GE	Hypoid Getriebe-/ Differentialöl SAE80W90, pro Liter	Hypoid Gearbox-/ Differential oil SAE80W90, per liter	A/R

**Hinweis
Note:**

* Differentialsperre D90MGA auf Anfrage!

Anmerkung: Umrüstung auf Speichenräder, hinten wie vorne, ohne Änderung der Antriebswelle - siehe Seite 72-73!

* Limited slip differential No. D90MGA - on request!

Note: easy conversion from steel to wire wheel, without changing halfshafts - see page 72-73!

**Hinweis
Note:**

Beachten Sie bitte die Hinweise zum Austausch-Differential auf Seite 169!

Please refer to our notes "Exchange Parts" on page 169!

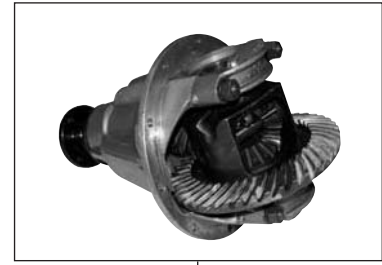
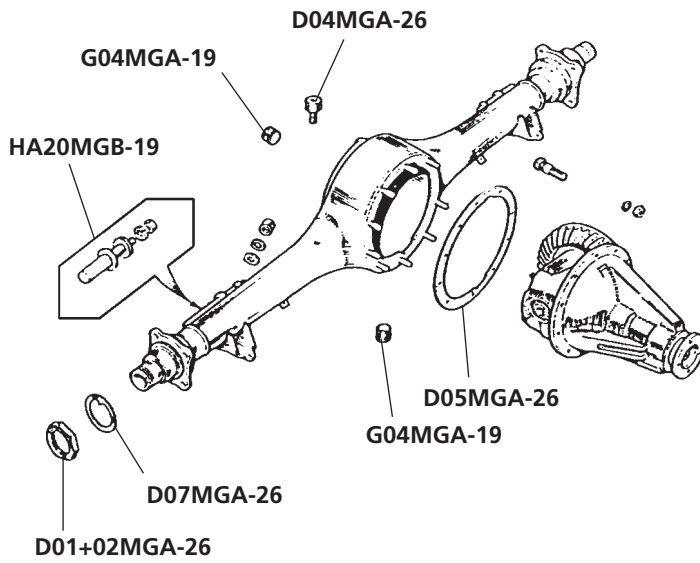

D01MGB/B-..

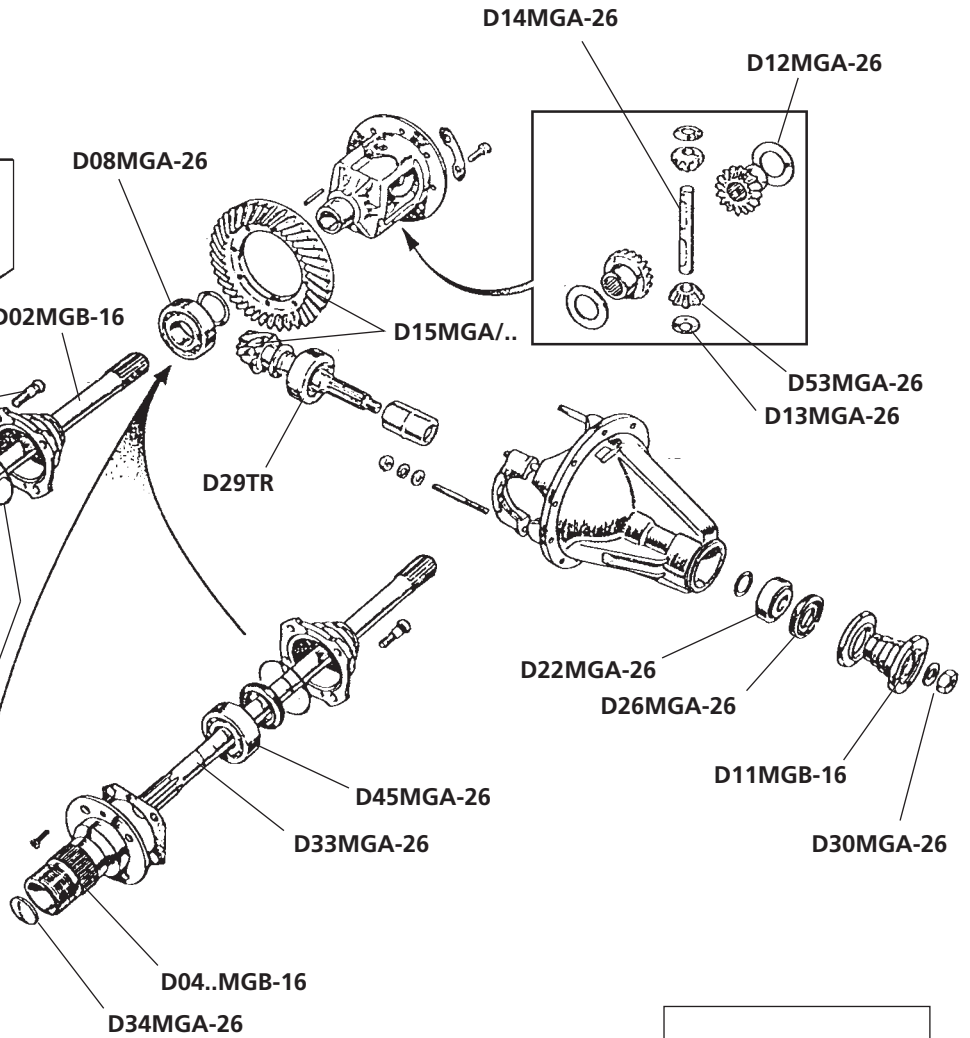
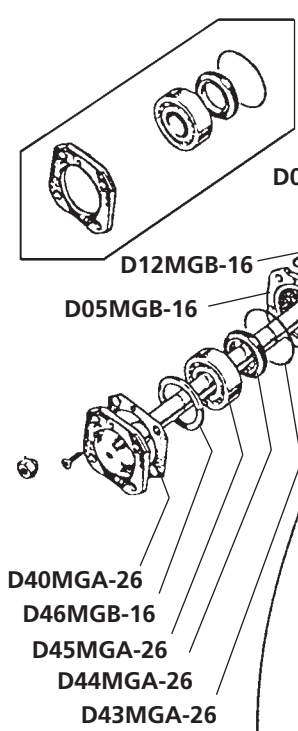
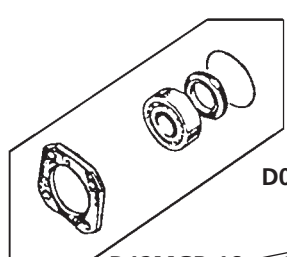

D300MGA

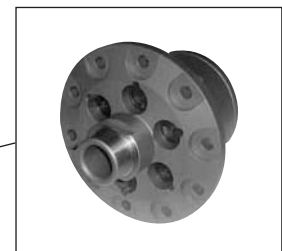

D90MGA

No.	Bezeichnung	Description	Anzahl/Qty.
D01MGB/..	AT-Differential (bitte gewünschte Übersetzung angeben)	Exchange differential (please refer transmission)	1
D03MGB	Deckel Differentialgehäuse	Rear cover	1
D04MGA-26	Entlüftung Differential	Breather differential	1
G04MGA-19	Öl-Einfüll/Ablaßstopfen	Drain plug	2
D12MGA-26	Anlaufscheibe Hinterachse	Thrust washer differential	2
D13MGA-26	Anlaufscheibe Hinterachse	Thrust washer differential	2
D15MGB/3.07	Teller- und Kegelrad 3.07	Crown wheel and pinion 3.07	1
D15MGB/3.7	Teller- und Kegelrad 3.7	Crown wheel and pinion 3.7	1
D15MGB/3.9	Teller- und Kegelrad 3.9	Crown wheel and pinion 3.9	1
B9AMGB-21	Mutter Bremstrommel Speichenrad	Nut brake drums whire wheel	8
HA20MGB-19	Reparaturbolzen unten	Bracket, check strap	2
D22MGB-16	Dichtung Differential-Deckel spät	Gasket differential cover late axle	1
D24MGB-16	Steckachse Speichenrad	Axle shaft wire wheels	2
D25MGB-16	Steckachse Scheibenrad spät	Axle shaft steel wheels late	2
D26MGB-16	Flansch Antriebswelle Scheibenräder	Flange drive hub disc wheels	2
D27MGB/RH	Speichenradnabe hinten rechts	Wire wheel hub RH	1
D27MGB/LH	Speichenradnabe hinten links	Wire wheel hub LH	1
D28MGB-16	Radbolzen Stahlfelge	Wheel stud steel wheels	8
D30MGB-16	Distanzteil Lager	Spacer bearing	2
D31MGB-16	Radlager hinten	Wheel bearing rear	2
D32MGB-16	Simmerring Getriebe/Hinterachse	Oil seal gearbox end/rear hub	2
D33MGB-16	Öldichtring-Einsatz	Oil seal collar - tube axle	2
D34MGB-16	Konus Achswelle	Cone axle	2
D35MGB-16	Mutter	Lock nut	2
D38MGB-16	Inneres Kegelradlager	Inner differential bearing	1
D39MGB-16	Stauchbuchse Lager	Spacer bearing collapsible	1
D40MGB-16	Kegelradlager aussen	Differential bearing outer	1
D41MGB-16	Simmerring Differential spät	Oil seal differential pinion late	1
VA42MGB-18	Radbolzen Speichenrad	Wheel stud wire wheel hub	1
D42MGB-16	Flansch Antriebswelle	Flange	1
D43MGB-16	Scheibe	Washer	1
D44MGB-16	Mutter Nylon	Nut nyloc	1
D53MGA-26	Planetenrad Differential	Planet gear differential	1
D56MGB/.135	Einstellscheibe 0.135"/3.43 mm	Shim, 0.135"/3.43 mm	A/R
D56MGB/.137	Einstellscheibe 0.137"/3.48 mm	Shim, 0.137"/3.48 mm	A/R
D57MGB-16	Lager Hinterachse ab 68	Bearing differential from 68	2
D58MGB-16	Kegelrad Hinterachse klein	Differential wheel	2
D62MGB-16	Welle Planetenrad	Pin pinion differential	1
D63MGB...	Einstellscheibe Kegelrad (bitte Größe angeben)	Shim, bearing (please refer dimension)	1
D90MGB	Differentialsperre *	Limited slip differential *	1
GE	Hypoid Getriebe-/ Differentialöl SAE80W90, pro Liter	Hypoid Gearbox-/ Differential oil SAE80W90, per liter	A/R

Hinweis
Note:

* Differentialsperre D90MGB auf Anfrage!

Anmerkung: Umrüstung auf Speichenräder, hinten wie vorne, ohne Änderung der Antriebswelle - siehe Seite 72-73!

* Limited slip differential No. D90MGB - on request!

Note: easy conversion from steel to wire wheel, without changing halfshafts - see page 72-73!

Hinweis
Note:

Beachten Sie bitte die Hinweise zum Austausch-Differential auf Seite 169!

Please refer to our notes "Exchange Parts" on page 169!



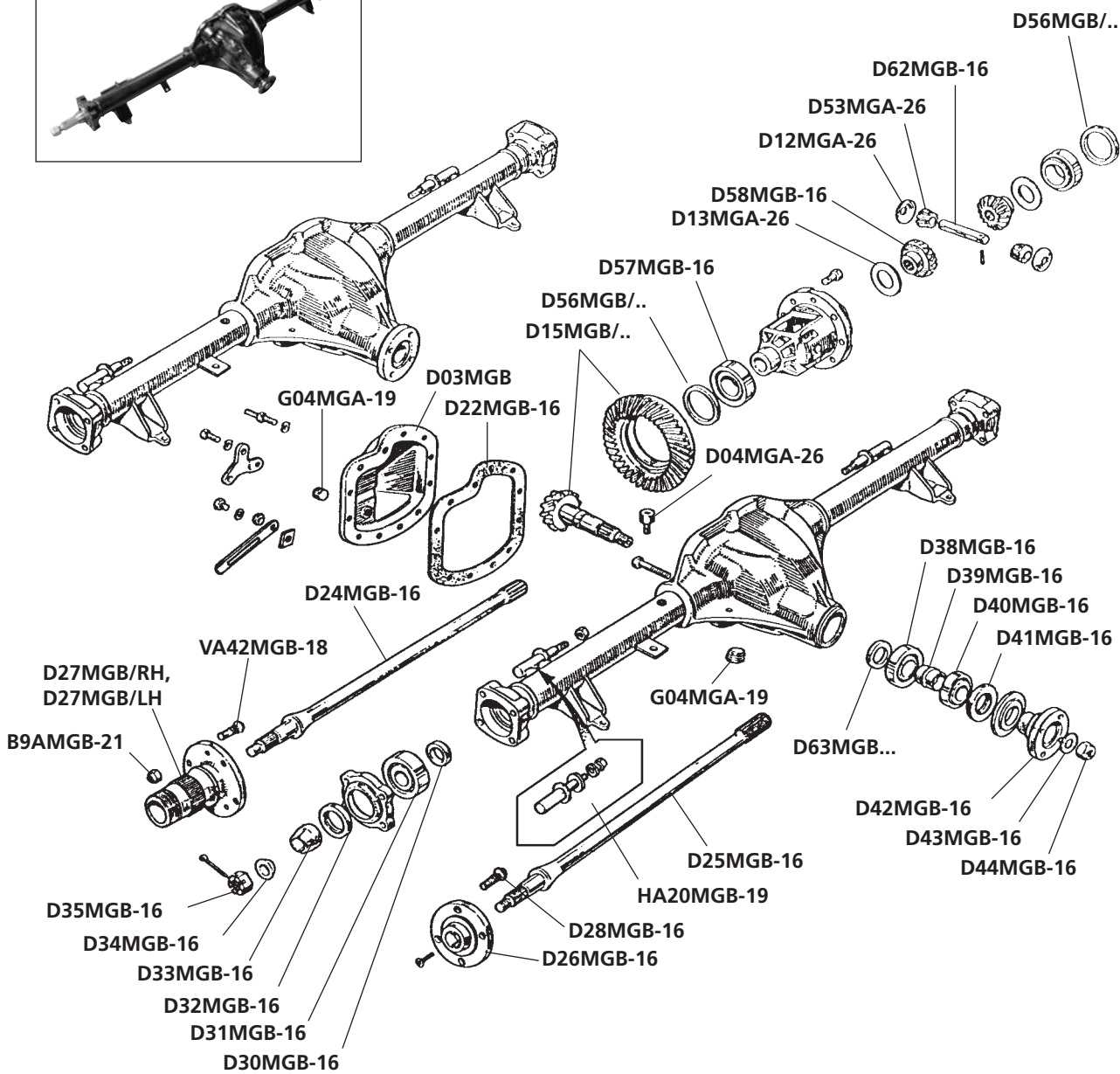

D90MGB*

Chromstoßstangen-Modelle (62-74)

Chrome bumper models (62-74)

No.	Bezeichnung	Description	Anzahl/Qty.
VA01MGB-18	Querträger vorne	Front crossmember	1
VA03MGB-18	Bolzen Querträger - 4x benötigt	Stud crossmember - 4x to be needed	4
VA04MGB-18	Unterlage oben (mit Lippe) - 4x benötigt	Pas upper (lipped) - 4x to be needed	4
VA04AMGB-18	Unterlage unten (flach) - 4x benötigt	Pas upper (flat) - 4x to be needed	4

Gummistoßstangen-Modelle (ab 74)

Rubber bumper models (from 74 on)

VA01AMGB-18	Querträger vorne	Front crossmember	1
VA02MGB-18	Bolzen Querträger - 2x benötigt	Stud crossmember - 2x to be needed	2
VA03MGB-18	Bolzen Querträger vorne - 2x benötigt	Stud front crossmember - 2x to be needed	2
VA04MGB-18	Unterlage (mit Lippe) - 6x benötigt	Pas (lipped) - 6x to be needed	6
VA04AMGB-18	Unterlage unten hinten (flach) - 2x benötigt	Pas upper rear (flat) - 2x to be needed	4
VA05MGA-23	Buchse Querträger vorne	Bush	2

alle Modelle

all models

VA6TR	Kronenmutter 7/16"	Crown nut 7/16"	2
VA06MGB-18	Klemmplatte Querträger	Clamp plate crossmember mounting	4
VA07MGB-18	Stossdämpfer vorne	Shocker absorber front	2
VA07MGBCOMP	Hebelstoßdämpfer (+25% härter)	Shocker absorber front Competition (+ 25% stronger)	2
VA08MGA-23	Distanz-Hülse Achsträger	Spacing tube link	2
VA08MGB-18	Lagerbolzen Achsträger oben	Pin fulcrum link to shocker	2
VA09MGA-23	Anlaufscheibe Achsträgerbolzen	Thrust washer king pin	4
VA09MGB-18	Lagerbuchse	Bearing bush	4
VA09MGB/P	Polyurethan Buchsen (ersetzt VA09MGB-18)	Polyurethan bearing bush (replaces VA09MGB-18)	4
VA10MGA-23	Trägerscheibe Staubdichtung	Seal support front suspension	4
VA11MGA-23	Schutzgummi Achsträger	Dust seal king pin	2
VA11MGB-18	Anschlaggummi Vorderachse	Buffer rubber front axle	2
VA11AMGB-18	Anschlaggummi Vorderachse kurz (empfehlenswert bei Verwendung von kurzen Federn)	Buffer rubber front axle short (to be recommended when lowered front springs fitted)	2
VA12MGA-23	Gummi-Buchse Querlenker unten	Rubber bush wishbone arm lower	8
VA17MGA-23	Scheibe	Washer	4
VA18MGA-23	Drehzapfen Querlenker unten	Wishbone pivot bottom	2
VA19MGA-23	Querlenker-Arm hinten	Wishbone arm rear	2
VA23MGA-23	Teller Spiralfeder vorne	Spring pan front	2
VA24SPT	Kronenmutter UNF 1/2"	Crown nut UNF 1/2"	2
VA26MGA-23	Bolzen Achsträger/Verbindung unten vorne	Bolt wishbone/link bottom front	2
VA35MGB-23	Distanzteil Anschlaggummi	Spacer rebound buffer	2
VA37MGA-23	Spiralfeder vorne Roadster	Front spring Roadster	2
VA37AMGA-23	Spiralfeder verstärkt und verkürzt, Roadster + GT mit TÜV-Gutachten	Front spring reinforced + lowered, Roadster & GT models – with TÜV-approval	2
VA39MGA-23	Spiralfeder GT	Front spring GT	2
VA41MGA-23	Achsträger unten vorne rechts	Wishbone arm lower front rh	1
VA42MGA-23	Achsträger unten vorne links	Wishbone arm lower front lh	1
VA70MGB	Buchsensatz Vorderachse oben **)	Bush kit front suspension upper **)	1
VA71MGB	Buchsensatz Vorderachse unten außen **)	Bush kit front suspension lower/outer **)	1
HSD	Hebel-Stossdämpfer-Öl, 0,5 Liter	Shocker oil, 0.5 liter	A/R



*) bitte Seite angeben

*) please refer side

**) Büchsensatz jeweils für eine Seite
- es werden 2 Sätze je Fahrzeug benötigt**) all bush kits for one side
- 2 bush kits needed for each car

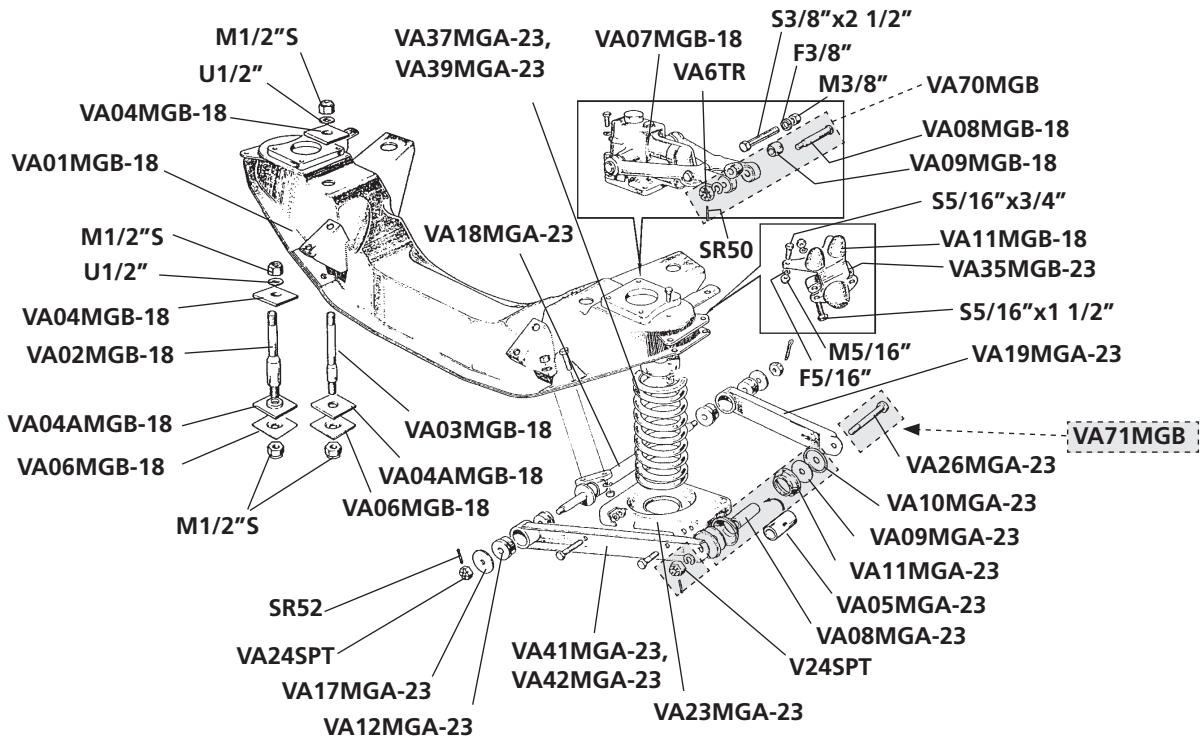

VA37MGA-23



VA37AMGA-23



VA75MGB



VA09MGB/P

No.	Bezeichnung	Description	Anzahl/Qty.
VA9VOPV	Kronenmutter UNF 5/8"	Crown nut UNF 5/8"	2
VA11SPT	Schmiernippel	Grease nipple	2
B11MGB	Befestigungsschraube Bremssattel	Bolt caliper	4
B12MGB	Sicherungsblech	Lock tab caliper	4
B16MGB	Befestigungsschraube Bremsscheibe zu Radflansch	Bolt brake disc	8
VA16MGB-23	Achsträgerbolzen-Satz	King pin kit	1
VA27MGB-18	Achsträger vorne *)	Swivel axle with pin *)	2
VA28MGB-18	Scheibe Bronze	Trust washer bronze	2
VA28MGB/0.055	Einstellscheibe 0,055"	Trust shim 0,055"	A/R
VA28MGB/0.060	Einstellscheibe 0,060"	Trust shim 0,060"	A/R
VA28MGB/0.065	Einstellscheibe 0,065"	Trust shim 0,065"	A/R
VA32MGB-18	Staubschutzhülsen-Satz	Dust tube kit	2
VA33MGB-18	Dichtung Staubschutzrohr	Seal dust tube	2
VA34MGB-18	Dichtung unten	Seal lower	2
VA35MGB-18	Lenkhebel *)	Steering lever *)	2
VA36MGB-18	Radlager-Satz vorne	Wheel bearing kit front	2
HA36MGA-25	Schmiernippel	Grease nipple	4
VA37MGB-18	Distanzteil Radlager	Spacer wheel bearing	2
VA38MGB-18	Ausgleich-Scheibe Radlager, Satz	Shim adjusting wheel bearing, kit	A/R
VA39MGB-18	Sicherung-Scheibe Radlager	Washer wheel bearing	2
VA40MGB-18	Lager Sicherungsmutter	Bearing nut retaining	2
VA41MGB-18	Radflansch Stahlfelge vorne	Wheel hub steel wheels front	2
VA42MGB-18	Radbolzen bis GHN/D5 490636	Wheel stud up to GHN/D5 490636	8
V42AMGB-18	Radbolzen spät ab GHN/D5 490637	Wheel stud late from GHN/D5 490637	8
VA44MGB-18	Fettkappe Scheibenfelge	Grease cap steel wheels	2
VA45MGB	Speichenradnabe 8 TPI vorne *) ab 64	Wire wheel hub 8 tpi front *) from 64	2
VA45AMGB	Speichenradnabe 12 TPI vorne *) bis 64	Wire wheel hub 12 tpi front *) up to 64	2
VA46MGB-18	Fettkappe Speichenfelge	Grease cap wire wheels	2
VA47MGB-18	Bolzen	Bolt	4
VA49MGB-18	Achsträgerlager oben	Top trunnion block	2
ZK65SPT	Mutter hochfest 3/8"	Nut 3/8"	8
VA72MGBCOMP	Nylatron Büchsenatz für Sportzwecke (ersetzt alle Gummibüchsen der Vorderachse) beide Seiten	Nylatron bush kit for competition use (replaces all front suspension rubber bushes) both sides	1
VA75MGB	Büchsenatz groß Vorderachse **) beinhaltet: VA70MGB, VA71MGB, VA16MGB + 8x VA12MGA-23	Bush kit front suspension **) contents: VA70MGB, VA71MGB, VA16MGB + 8x VA12MGA-23	1
VA80MGB	Umrüstsatz auf Koni-Stoßdämpfer vorne (ohne Dämpfer) – mit TÜV-Gutachten	Fitting kit for Koni shock absorbers (w/o absorber) – with TÜV-approval	1
VA80AMGB	Stoßdämpfer für Umrüstsatz VA80MGB	Shock absorber to no. VA80MGB	1
WZ102	Reibale für Büchsen Achsträgerbolzen	Reamer, king pin bush	1



*) bitte Seite angeben

*) please refer side

**) Büchsenatz jeweils für eine Seite
- es werden 2 Sätze je Fahrzeug benötigt

**) all bush kits for one side
- 2 bush kits needed for each car

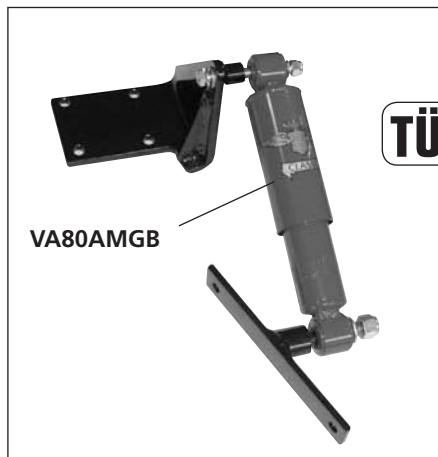
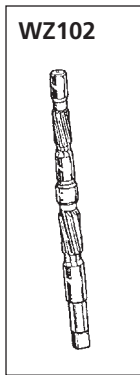
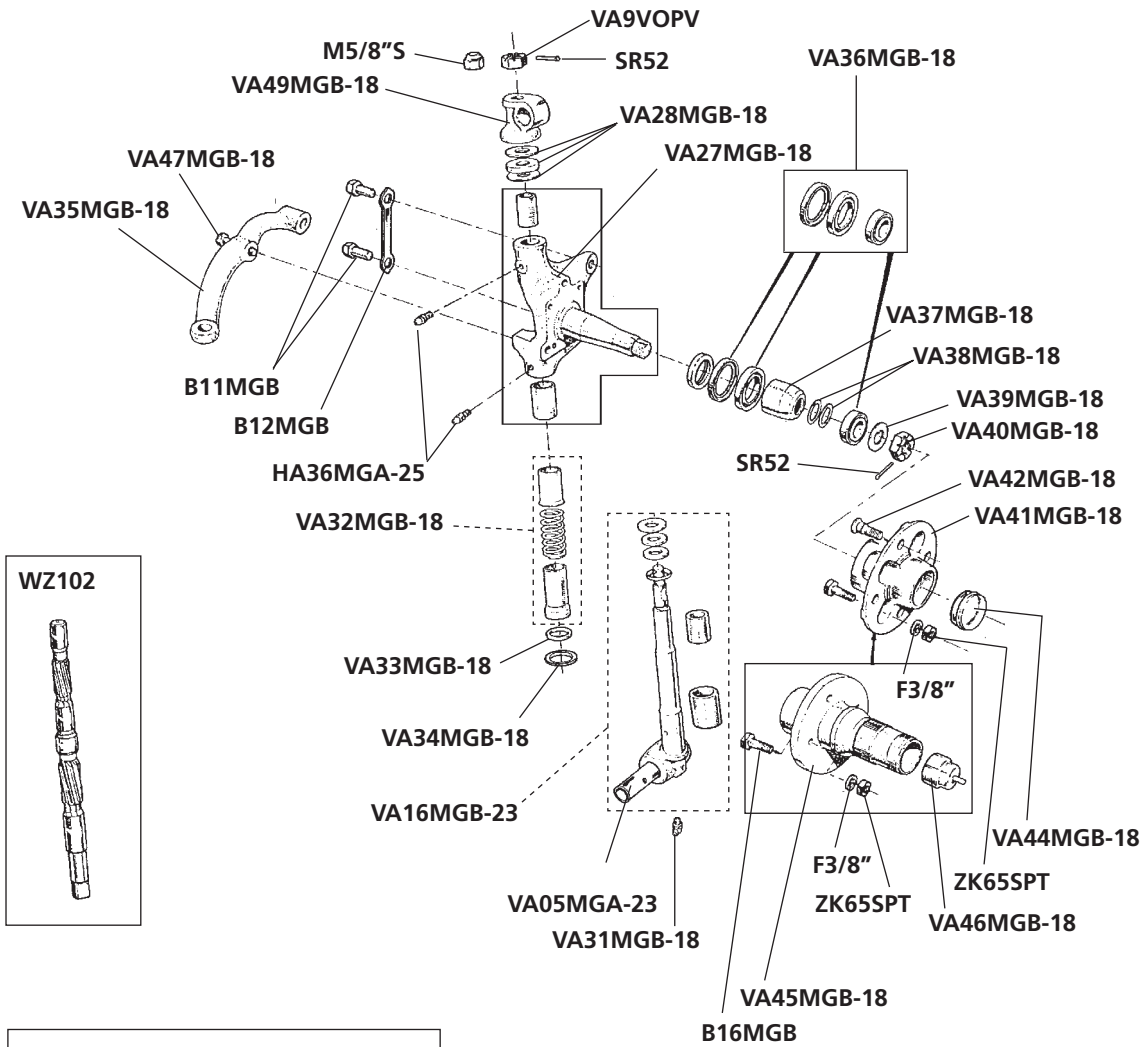

Stabilisator 9/16" (14,3 mm)**Anti-roll bar 9/16" (14,3 mm)**

No.	Bezeichnung	Description	Anzahl/Qty.
VA50MGB-9/16"	Stabilisator Ø 9/16" (14,3 mm) *	Anti-roll bar Ø 9/16" (14,3 mm) *	1
VA51MGB-9/16"	Haltegummi Stabilisator Ø 9/16" (14,3 mm)	Bush mounting to anti-roll bar Ø 9/16" (14,3 mm)	2
VA52MGB	Endanschlag-Satz (für eine Seite)	End stop kit (for one side)	2

Stabilisator 5/8" (15,9 mm)**Anti-roll bar 5/8" (15,9 mm)**

VA50MGB-5/8"	Stabilisator Ø 5/8" (15,9 mm)	Anti-roll bar Ø 5/8" (15,9 mm)	1
VA51MGB-5/8"	Haltegummi Stabilisator Ø 5/8" (15,9 mm)	Bush mounting to anti-roll bar Ø 5/8" (15,9 mm)	2
VA52MGB	Endanschlag-Satz (für eine Seite)	End stop kit (for one side)	2

**Stabilisator 7/8" (22 mm) Competition
- für Sportzwecke****Anti-roll bar 7/8" (22 mm) Competition
- for competition use**

VA50MGB-7/8"	Stabilisator Ø 7/8" (22 mm)	Anti-roll bar Ø 7/8" (22 mm)	1
VA51MGB-7/8"	Neopren-Lager für Competition Stabilisator	Neopren bush mounting to Competition anti-roll bar	1

alle Modelle**all models**

HA26MGB-19	Halter	Bracket	2
VA54MGB	Büchse Stabilisator außen	Eye bush, anti-roll bar	2
VA54AMGB	Büchse Stabilisator außen Nylotren für Sportzwecke	Eye bush, anti-roll bar Nylotren for competition use	2
VA55MGBL	Stabilisatorgelenk außen, links	Link anti-roll bar outer lh	1
VA55MGBR	Stabilisatorgelenk außen, rechts	Link anti-roll bar outer rh	1
VA55AMGB	Stabilisatorgelenk außen mit Uniball-Gelenk	Link anti-roll bar outer with Uniball-link	2
SR14	Linsenkopfschraube 3/16"x3/4"	Countersunk screw 3/16"x3/4"	4

**Übersicht Stabilisatoren MGB
(Vorderachse)**

Baujahr	Fahrzeugtyp	ab Fgst.Nr	bis Fgst.Nr	Ausstattung
Roadster-Modelle				
62-67	3 Synchro	GHN3 101	GHN3 138400	optional
67-74	4 Synchro Chromstoßstange	GHN4 138401	GHN5 360300	9/16" (14,3 mm)
75-76	Gummistoßstange früh	GHN5 360301	GHN5 410000	nicht montiert
ab 76	Gummistoßstange spät	GHN5 410001	bis Ende	5/8" (15,9 mm)
GT-Modelle				
65-74	Chromstoßstange	GHD3 71933	GHD5 361000	5/8" (15,9 mm)
74-76	Gummistoßstange früh	GHD5 361001	GHD5 410000	9/16" (14,3 mm)
ab 76	Gummistoßstange spät inkl. V8	GHD5 410001	bis Ende	5/8" (15,9 mm)
Competition (für Sportzwecke) alle Roadster + GT				7/8" (22mm)

**Summary of Anti-Roll Bars MGB
(Front Suspension)**

Year	Vehicle Type	From Chassis No.	To Chassis No.	Original Specification
Roadster-Models				
62-67	3 Synchro	GHN3 101	GHN3 138400	Optional
67-74	4 Synchro Chrome Bumper	GHN4 138401	GHN5 360300	9/16" (14,3 mm)
75-76	Early Rubber Bumper	GHN5 360301	GHN5 410000	Not Fitted
ab 76	Late Rubber Bumper	GHN5 410001	To End	5/8" (15,9 mm)
GT-Models				
65-74	Chrome Bumper	GHD3 71933	GHD5 361000	5/8" (15,9 mm)
74-76	Early Rubber Bumper	GHD5 361001	GHD5 410000	9/16" (14,3 mm)
76 on	Late Rubber Bumper inc. V8	GHD5 410001	To End	5/8" (15,9 mm)
Competition (for competition use) All Roadster + GT Models				7/8" (22mm)

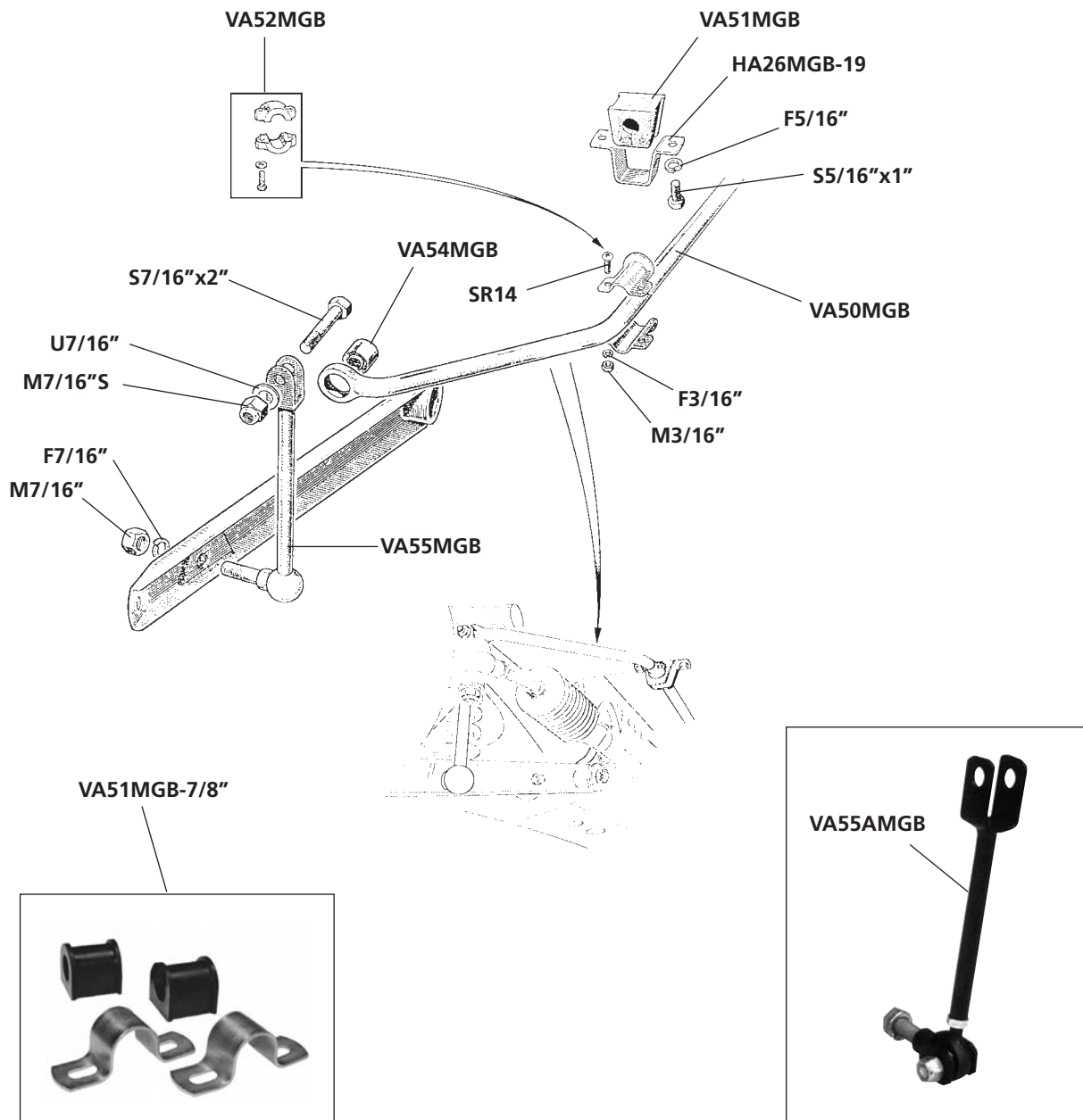

Hinweis 

Note:

*) Der Stabilisator 9/16" (Art. VA50MGB-9/16") ist leider nicht mehr lieferbar. Bitte verwenden Sie den Stabilisator 5/8" oder 7/8" mit den entsprechenden Haltegummis/Lager.

*) The anti-roll bar (no. VA50MGB-9/16") is no longer available. Please fit anti-rollbar 5/8" or 7/8" with corresponding bush mountings.

No.	Bezeichnung	Description	Anzahl/Qty.
L01MGB-17	Lenkung LHD Chromstoßstangen-Modell bis 1974	Steering rack LHD chrome bumper model up to 1974	1
L01MGB-RHD	Lenkung RHD Chromstoßstangen-Modell bis 1974	Steering rack RHD chrome bumper model up to 1974	1
L02MGB-17	Lenkung LHD Gummistoßstangen-Modell ab 1974	Steering rack LHD rubber bumper model from 1974	1
L02MGB-RHD	Lenkung RHD Gummistoßstangen-Modell ab 1974	Steering rack RHD rubber bumper model from 1974	1
L03MGA-17	Kreuzgelenk Lenksäule Chromstoßstangen-Modell	Universal joint steering column, chrome bumper model	1
L04MGB-17	Simmerring Lenkritzel	Oil seal steering pinion	1
L04AMGB-17	Dichtung Lenkritzel	Gasket,cover	1
L05MGB-17	Spurstangenkopf	Track rod end	2
HM9/16"	Kontermutter Spurstangenkopf	Nut track rod end	2
VA6TR	Kronenmutter 7/16"	Crown nut 7/16"	2
L44MGB	Lenkmanschetten-Satz	Rack bellows set +clips	1
L12MGB-17	Hupenknopf bis Bj. 72	Horn push button up to 72	1
L12AMGB-17	Rotor bis 1972	Rotor up to 72	1
L12BMGB-17	Schleifring bis 1972	Slip ring up to 72	1
L13MGB-17	Hupenknopf schwarz, Abzeichen gold ab 72	Horn push button gold badge from 72 on	1
L14MGB-17	Abzeichen Lenkradmitte, schwarzes Emblem ab 77	Emblem steering wheel centre, black badge from 77	1
L14AMGB-17	Abzeichen Lenkradmitte, schwarz/silbernes Emblem ab 77	Emblem steering wheel centre, black/silver badge from 77	1
L14BMGB-17	Abzeichen Lenkradmitte, silber/rotes Emblem ab 77	Emblem steering wheel centre, silver/red badge from 77	1
L15MGB-17	Mutter Lenkradbefestigung ab 72	Nut steering wheel from 72	1
L17MGB-17	Lagerbuchse Lenksäule (ohne Sicherheitslenksäule) für Lenksäule ohne Lenkradschloß	Bearing bush steering column (non collapsible) for steering column without steering lock	1
L18MGB-17	Lagerbuchse Lenksäule (ohne Sicherheitslenksäule) für Lenksäule mit Lenkradschloß	Bearing bush steering column (non collapsible) for steering column with steering lock	1
L20MGB-17	Staubschutzgummi Lenksäule	Dust excluder steering column	1
L22MGB-17	Lagerbuchse oben ab 72	Bush upper from 72	1
L23MGB-17	Lagerbuchse unten ab 72	Bush lower from 72	1
L25MGB-17	Dichtring Lenksäule (Gummistoßstangen-Modell)	Sealing ring steering column (rubber bumper model)	1
L25MGA-27	Mutter Lenkradbefestigung (ohne Sicherheitslenksäule) bis 72	Nut steering wheel (steering column non collapsible) up to 72	1
L26MGB-17	Kreuzgelenk Lenksäule (Gummistoßstangen-Modell)	Universal joint steering column (rubber bumper model)	1
L30MGB-17	Kontaktstift Hupe	Horn push brush	1
L31MGB-17	Hupenschleifring ab 72	Horn slip ring from 72 on	1
SR51	Splint	Split pin	2
L61ASPT	Buchse Lenksäule oben (ohne Sicherheitslenksäule)	Bush top steering column (steering column non collapsible)	1
E120MGB	Lenkradschloß bis 1976	Steering lock up to 1976	1
E120AMGB	Lenkradschloß ab 1976 ab GHN/D..*)	Steering lock from 1976 from GHN/D..*)	1
E121MGB	Abreisschraube	Shear head bolt	2
E122MGB	Elektroteil Lenkradschloß bis 1976	Ignition switch up to 1976	1
E122AMGB	Elektroteil Lenkradschloß ab 1976, GHN/D..*)	Ignition switch from 1976 GHN/D..*)	1

Hinweis
Note:

Anmerkung: „Sport-Lenkräder (Holz oder Leder)
siehe Seite 70-71!

Note: Sport steering wheels - wooden and leather
see page 70-71!

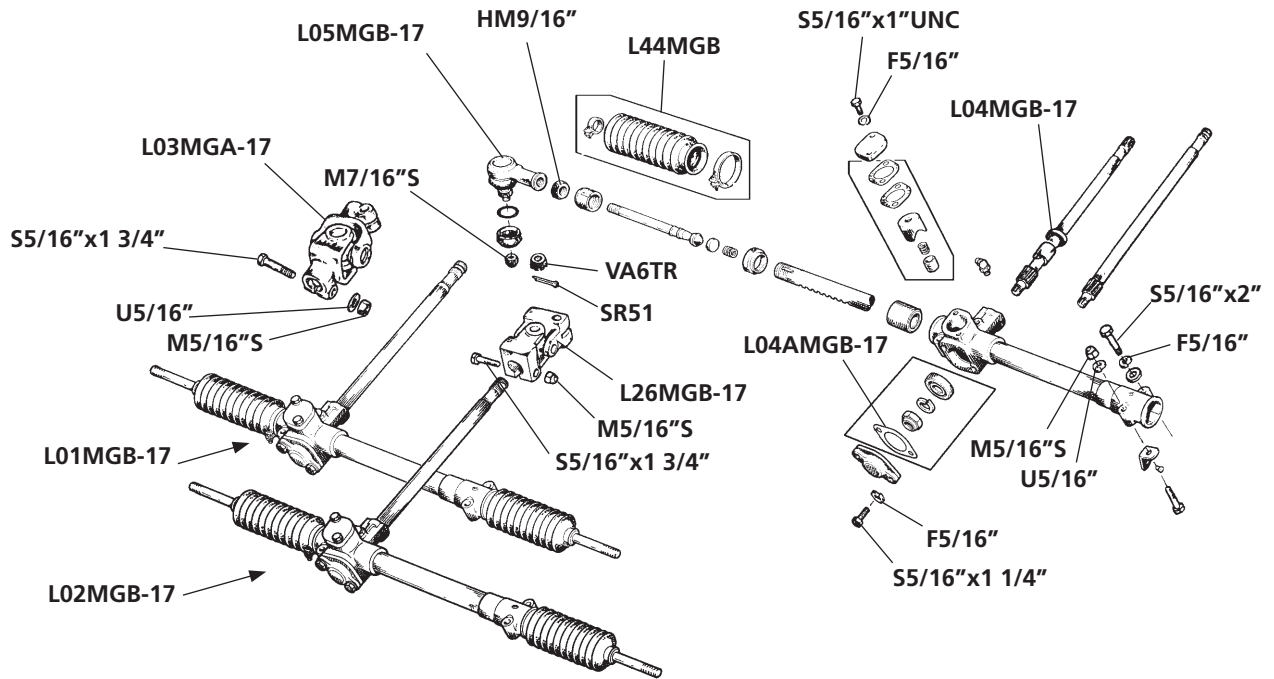

Bj. 1962-72
 ohne Sicherheitslenksäule / non collapsible

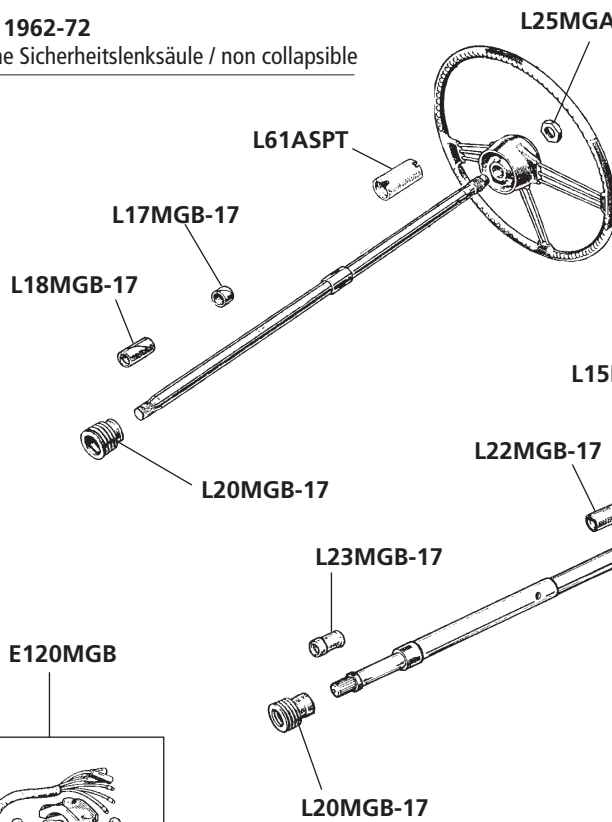

ab Bj. / from 72
 mit Sicherheitslenksäule / collapsible

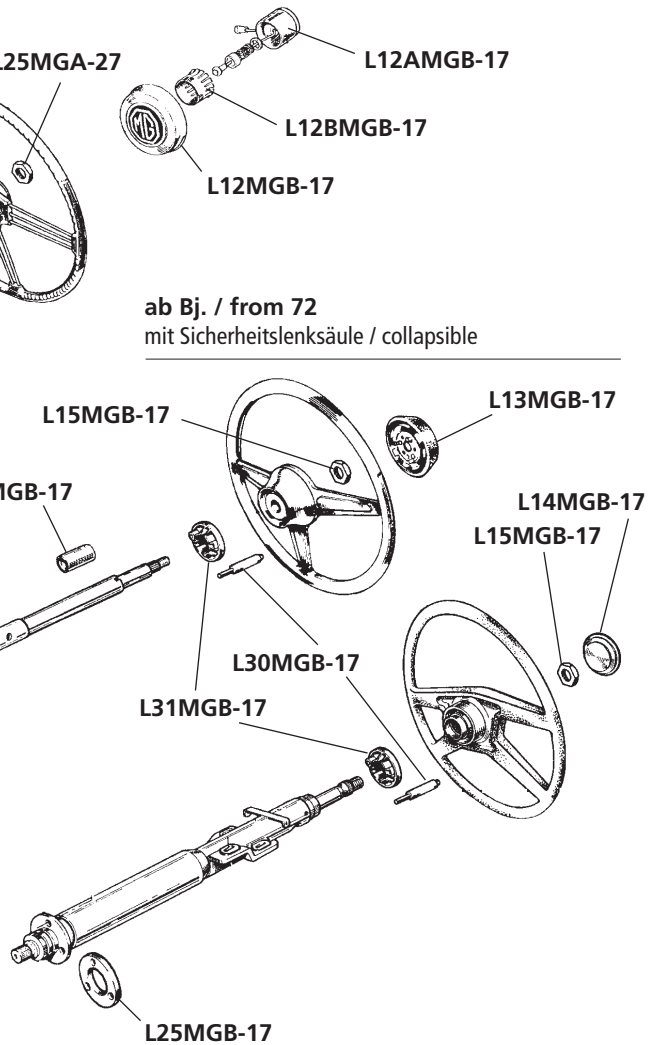
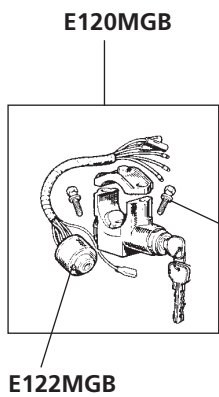

Sportlenkräder ohne ABE

Sport steering wheels w/o homologation

No.	Bezeichnung	Description	Anzahl/Qty.
L100TR	Lenkrad 13" Leder - gelocht, geschüsselt	Steering wheel 13" leather - drilled, bowl form	1
L101TR	Lenkrad 13" Leder - gelocht, flach	Steering wheel 13" leather - drilled, plain	1
L102TR	Lenkrad 13" Leder - gerautet, geschüsselt	Steering wheel 13" leather - riveted, bowl form	1
L103TR	Lenkrad 13" Leder - gerautet, flach	Steering wheel 13" leather - riveted, plain	1
L110TR	Lenkrad 14" Leder - gelocht, geschüsselt	Steering wheel 14" leather - drilled, bowl form	1
L111TR	Lenkrad 14" Leder - gelocht, flach	Steering wheel 14" leather - drilled, plain	1
L112TR	Lenkrad 14" Leder - gerautet, geschüsselt	Steering wheel 14" leather - riveted, bowl form	1
L113TR	Lenkrad 14" Leder - gerautet, flach	Steering wheel 14" leather - riveted, plain	1
L120TR	Lenkrad 15" Leder - gelocht, geschüsselt	Steering wheel 15" leather - drilled, bowl form	1
L121TR	Lenkrad 15" Leder - gelocht, flach	Steering wheel 15" leather - drilled, plain	1
L122TR	Lenkrad 15" Leder - gerautet, geschüsselt	Steering wheel 15" leather - riveted, bowl form	1
L123TR	Lenkrad 15" Leder - gerautet, flach	Steering wheel 15" leather - riveted, plain	1
L130TR	Lenkrad 13" Holz - gelocht, geschüsselt	Steering wheel 13" wood - drilled, bowl form	1
L131TR	Lenkrad 13" Holz - gelocht, flach	Steering wheel 13" wood - drilled, plain	1
L132TR	Lenkrad 13" Holz - gerautet, geschüsselt	Steering wheel 13" wood - riveted, bowl form	1
L133TR	Lenkrad 13" Holz - gerautet, flach	Steering wheel 13" wood - riveted, plain	1
L140TR	Lenkrad 14" Holz - gelocht, geschüsselt	Steering wheel 14" wood - drilled, bowl form	1
L141TR	Lenkrad 14" Holz - gelocht, flach	Steering wheel 14" wood - drilled, plain	1
L142TR	Lenkrad 14" Holz - gerautet, geschüsselt	Steering wheel 14" wood - riveted, bowl form	1
L143TR	Lenkrad 14" Holz - gerautet, flach	Steering wheel 14" wood - riveted, plain	1
L150TR	Lenkrad 15" Holz - gelocht, geschüsselt	Steering wheel 15" wood - drilled, bowl form	1
L151TR	Lenkrad 15" Holz - gelocht, flach	Steering wheel 15" wood - drilled, plain	1
L152TR	Lenkrad 15" Holz - gerautet, geschüsselt	Steering wheel 15" wood - riveted, bowl form	1
L153TR	Lenkrad 15" Holz - gerautet, flach	Steering wheel 15" wood - riveted, plain	1
L160TR	Lenkrad 14" Vollholz, ohne Nieten - Speichen silberfarben, geschüsselt	Steering wheel 14" wood - drilled, without rivets - spokes silver, bowl form	1
L170TR	Lenkrad 15" Holz - 4 Speichen, flach	Steering wheel 15" wood - riveted, 4 spokes, plain	1

Adapter für Sportlenkrad:

(auch passend für Moto-Lita Lenkräder)

Adaptor for sport steering wheel:

(also suitable for Moto-Lita steering wheels)

LB25MGB	Bj. 1963-70 (ohne Sicherheitslenksäule)	1963-70 (steering column non collapsible)	1
LB25AMGB	Bj. 1968-70 (mit Sicherheitslenksäule) USA	1968-70 (steering column collapsible) USA	1
LB25BMGB	Bj. 1970-72 (ohne Sicherheitslenksäule)	1970-72 (steering column non collapsible)	1
LB25CMGB	Bj. 1970-77 (mit Sicherheitslenksäule)	1970-77 (steering column collapsible)	1
LB25DMGB	ab Bj. 1977 (mit Sicherheitslenksäule)	from 1977 (steering column collapsible)	1
E131MGBML	Hupenkontaktstift	Horn push, pencil type	1

Adapter auch für weitere Fahrzeugtypen
lieferbar - bitte fragen Sie nach !

Adaptors also available for other cars - please enquire !

E131MGBML

Schema: Lenkrad flach
Scheme: steering wheel plain

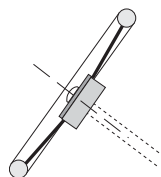

Schema: Lenkrad geschüsselt
Scheme: steering wheel bowl form

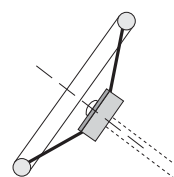



Beispiel: Lenkrad Holz - gelocht
Example: Steering wheel wood - drilled



Beispiel: Lenkrad Leder - gelocht
Example: Steering wheel leather - drilled



Beispiel: Lenkrad Vollholz - gerautet, ohne Nieten
Example: Steering wheel wood - without rivets



Beispiel: Lenkrad Holz - 4 Speichen
Example: Steering wheel wood - 4 spokes

Innenausstattungssteile finden Sie
ab Seite 110.

Interior trim and fittings - see
page 110 following.





Speichenräder / Wire wheels • lackiert und chrom
• painted and chrome finish



F15MGB-42 4 1/2 x 14"



F15AMGB-42 5 1/2 x 14"



F15BMGB-42 4 1/2 x 14"

Speichenfelge / Wire Wheel

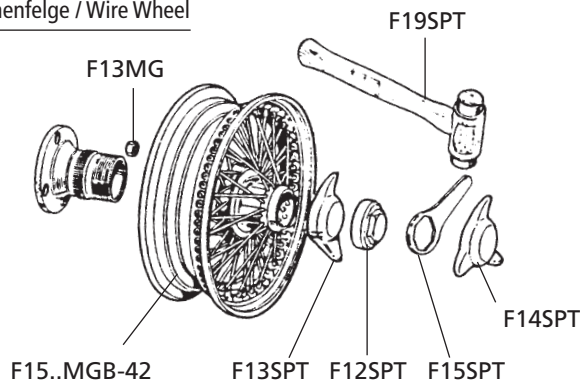

F15CMGB-42 5 1/2 x 14"

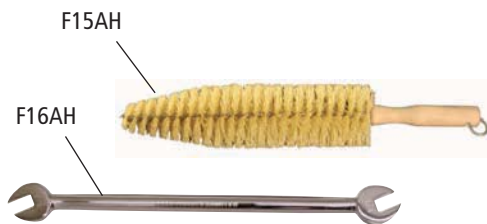

F12SPT,
F04AMGA-36,
F18MGA-36,
F18AMGA-36



F13SPT,
F07AMGA-36,
F20MGA-36,
F22MGA-36



F14SPT,
F24MGA-36



F15SPT



F16SPT



F17SPT

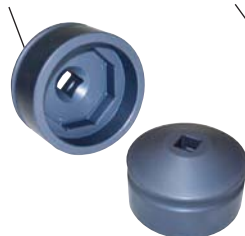

F18SPT



Speichenräder

Wire wheels

No.	Bezeichnung	Description	Anzahl/Qty.
F15AMGB-42	Speichenfelge 5,5 x 14 lackiert (70 Speichen)	Wire wheel 5,5 x 14 painted (70 spokes)	4
F15BMGB-42	Speichenfelge 4,5 x 14 chrom (60 Speichen)	Wire wheel 4,5 x 14 chrome (60 spokes)	4
F15CMGB-42	Speichenfelge 5,5 x 14 chrom (70 Speichen)	Wire wheel 5,5 x 14 chrome (70 spokes)	4
F15MGB-42	Speichenfelge 4,5 x 14 lackiert (60 Speichen)	Wire wheel 4,5 x 14 painted (60 spokes)	4
Speichenradmuttern 8tpi *		Wire wheel nuts 8tpi *	
F12SPT	Achtkantmutter 8tpi ¹⁾	Octagon wheel nut 8 tpi ¹⁾	4
F04AMGA-36	Achtkantmutter 8tpi -MG-Logo ¹⁾	Octagon wheel nut 8 tpi -MG-logo ¹⁾	4
F13SPT	Flügelmutter 2-Zack 8tpi *)	Spinner 2-eared 8 tpi ¹⁾	4
F07AMGA-36	Flügelmutter 2-Zack -MG-Logo 8 tpi ¹⁾	Spinner 2-eared -MG-logo 8 tpi ¹⁾	4
F14SPT	Flügelmutter 3-Flügel 8tpi *)	Spinner 3-eared 8 tpi ¹⁾	4
Speichenradmuttern 12tpi *		Wire wheel nuts 12tpi *	
F18MGA-36	Achtkantmutter 12tpi ¹⁾	Octagon wheel nut 12 tpi ¹⁾	4
F18AMGA-36	Achtkantmutter 12tpi -MG-Logo ¹⁾	Octagon wheel nut 12 tpi -MG-logo ¹⁾	4
F20MGA-36	Flügelmutter 2-Zack -MG-Logo 12tpi ¹⁾	Spinner 2-eared -MG-logo 12 tpi ¹⁾	4
F22MGA-36	Flügelmutter 2-Zack 12tpi ¹⁾	Spinner 2-eared 12 tpi ¹⁾	4
F24MGA-36	Flügelmutter 3-Fach 12tpi ¹⁾	Spinner 3-eared 12 tpi ¹⁾	4
Umrüstsätze Speichenfelge ²⁾		Wire wheel fitting kits ²⁾	
F22MGB-42	Umrüstsatz auf Speichenfelge mit 8-Kantmuttern, Banjo-Achse ³⁾	Wire wheel fitting kit, octagon wheel nuts banjo-axle ³⁾	1
F22AMGB-42	Umrüstsatz auf Speichenfelge mit 2-Flügelmutter, Banjo-Achse ³⁾	Wire wheel fitting kit, 2-eared spinner - banjo-axle ³⁾	1
F23MGB-42	Umrüst-Satz auf Speichenfelge mit 8-Kantmuttern, Tube-Axle ³⁾	Wire wheel fitting kit wing nuts - tube axle ³⁾	1
F23AMGB-42	Umrüstsatz auf Speichenfelge mit 2-Flügelmutter, Tube-Axle ³⁾	Wire wheel fitting kit, 2-eared spinner - tube-axle ³⁾	1
F15SPT	Schlüssel für Achtkant-Zentralverschluß	Octagon wheel nut spanner	1
F15AH	Speichenfelge Reinigungsbürste	Wire wheel cleaning brush	1
F16SPT	Speichenradschlüssel Messing	Octagon wheel nut spanner brass	1
F17SPT	Steckschlüssel Alu eloxiert für 8-Kant Mutter	Aluminium socket wheel, octagon wheel nut	1
F18SPT	Steckschlüssel für 2-Zack Flügelmutter	Socket wheel, 2-eared spinner	1
F19SPT	Kupfer-, Leder- Hammer	Copper hide hammer	1
F19MGB-42	Radkappe Rostyle	Hub cap rostyle	4
F20MGB-42	Radkappen-Abzeichen Rostyle	Hub cap motif rostyle	4
F21MGB-42	Radkappe frühe Stahlfelge	Hub cap early disc wheel	4
F30SPT	Kupferpaste für Speichenradadapter 80 g	Copper lubrication for splines, 80 g	1
F52TR	Spurverbreiterungssatz 6 mm (Achssatz)	Wheel spacers 6 mm (axle kit)	A/R

Hinweis **Note:**

* 8tpi = Grobgewinde Nachrüstspeichenräder
 12tpi = Feingewinde für Fahrzeuge mit serienmäßigen
 Speichenrädern

* 8tpi = MGA converted to wire wheels
 12tpi = all MGA original equipped with wire wheels

- 1) Bitte Seite angeben
 2) Satz = 4x Speichenradadapter, 4x Zentralverschluß-mutter,
 benötigte Kleinteile und Montageanleitung
 3) Einzelne Speichenradadapter auf Anfrage

- 1) Please refer side
 2) Kit = 4x wire wheel adaptor, 4x centre wheel nut, all
 required fitting parts + fitting description
 3) Single wire wheel adaptors on demand

Hinweis **Note:**

Alle Chromspeichenräder jetzt mit Edelstahlspeichen.
 Wir gewähren 2 Jahre Garantie auf alle Speichenräder.
 - Einzelne Speichen auf Anfrage!

auch lieferbar:
 15" Felgen Speichenräder (= MGA/MGC)

The wire wheels are equipped with stainless steel spokes. All
 our wire wheels with 2 years-guarantee.
 - Single spokes on demand!

Also available:
 15" wire wheels (= MGA/MGC)



Alu-Felge / Alloy wheel



F26MGB-42 5 x 14"

Minilite Style



F29MGB-42 5 1/2 x 14"



F50MGB 5 1/2 x 14" 6 x 14"

Stahlfelge / Steel wheel

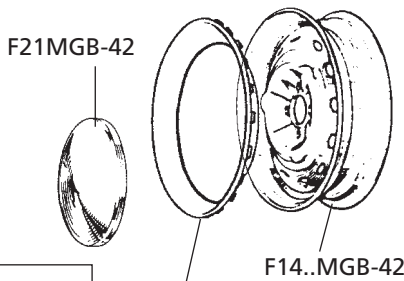

F21MGB-42 F14..MGB-42

Rostyle-Felge / Rostyle wheel

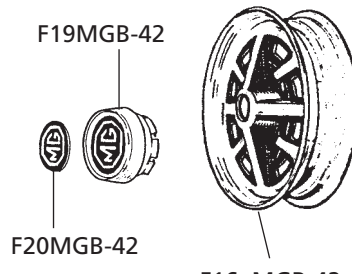

F19MGB-42 F20MGB-42 F16..MGB-42

Alu-Felge / Alloy wheel

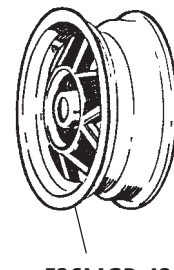

F26MGB-42

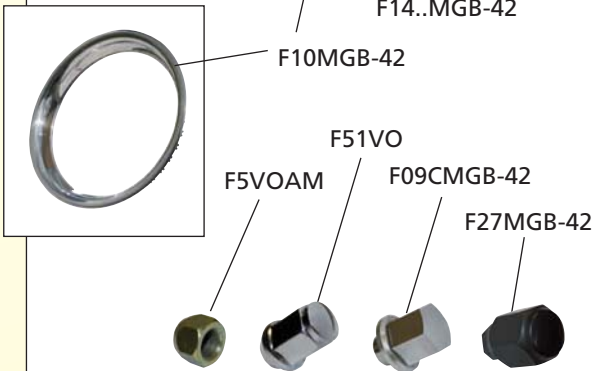

F10MGB-42 F51VO F5VOAM F09CMGB-42 F27MGB-42



F52TR



F23MGB-42

F12SPT, F04AMGA-36, F18MGA-36, F18AMGA-36



F13SPT, F07AMGA-36, F20MGA-36, F22MGA-36



F14SPT, F24MGA-36



F19SPT



F30SPT

F15SPT



F16SPT



F17SPT

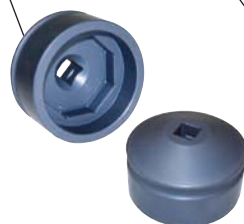

F18SPT



Stahl & Alu-Felgen

Steel & alloy wheels

No.	Bezeichnung	Description	Anzahl/Qty.
F14AMGB-42	AT-Stahlfelge früher MGB-GT 5 x 14"	Exch. road wheel early MGB-GT 5 x 14"	4
F14MGB-42	Stahlfelge früher MGB-Roadster 4 x 14"	Road wheel early tourer 4 x 14"	4
F16AMGB-42	Stahlfelge Rostyle chrom 5 x 14"	Steel wheel rostyle chrome 5 x 14"	4
F16MGB-42	Stahlfelge Rostyle lackiert 5 x 14"	Steel wheel rostyle painted 5 x 14"	4
F26MGB-42	Alu-Felge 5 x 14"	Wheel alloy Limited Edition 5 1/2 x 14"	4
F29MGB-42	Minilite-Style-Alu-Felge 5 1/2 x 14" Zentralverschluß	Minilite-style wheel 5 1/2 x 14" centre lock	4
F50MGB	Minilite-Style-Alu-Felge 5 1/2 x 14"	Minilite-style wheel 5 1/2 x 14"	4
F50MGB-6x14"	Minilite-Style-Alu-Felge 6.0 x 14"	Minilite-style wheel 6.0 x 14"	4
Zentralverschluß Zubehör 8tpi *		Centre lock accessories 8tpi *	
F12SPT	Achtkantmutter 8tpi ¹⁾	Octagon wheel nut 8 tpi ¹⁾	4
F04AMGA-36	Achtkantmutter 8tpi -MG-Logo ¹⁾	Octagon wheel nut 8 tpi -MG-logo ¹⁾	4
F13SPT	Flügelmutter 2-Zack 8tpi *)	Spinner 2-eared 8 tpi ¹⁾	4
F07AMGA-36	Flügelmutter 2-Zack -MG-Logo 8 tpi ¹⁾	Spinner 2-eared -MG-logo 8 tpi ¹⁾	4
F14SPT	Flügelmutter 3-Flügel 8tpi *)	Spinner 3-eared 8 tpi ¹⁾	4
Zentralverschluß Zubehör 12tpi *		Centre lock accessories 12tpi *	
F18MGA-36	Achtkantmutter 12tpi ¹⁾	Octagon wheel nut 12 tpi ¹⁾	4
F18AMGA-36	Achtkantmutter 12tpi -MG-Logo ¹⁾	Octagon wheel nut 12 tpi -MG-logo ¹⁾	4
F20MGA-36	Flügelmutter 2-Zack -MG-Logo 12tpi ¹⁾	Spinner 2-eared -MG-logo 12 tpi ¹⁾	4
F22MGA-36	Flügelmutter 2-Zack 12tpi ¹⁾	Spinner 2-eared 12 tpi ¹⁾	4
F24MGA-36	Flügelmutter 3-Fach 12tpi ¹⁾	Spinner 3-eared 12 tpi ¹⁾	4
Umrüstsätze Zentralverschluß ²⁾		Centre lock fitting kits ²⁾	
F22MGB-42	Umrüstsatz auf Zentralverschluß mit 8-Kantmutter, Banjo-Achse ³⁾	Centre lock fitting kit, octagon wheel nuts banjo-axle ³⁾	1
F22AMGB-42	Umrüstsatz auf Zentralverschluß mit 2-Flügelmutter, Banjo-Achse ³⁾	Centre lock fitting kit, 2-eared spinner - banjo-axle ³⁾	1
F23MGB-42	Umrüst-Satz auf Zentralverschluß mit 8-Kantmutter, Tube-Achse ³⁾	Centre lock fitting kit wing nuts - tube axle ³⁾	1
F23AMGB-42	Umrüstsatz auf Zentralverschluß mit 2-Flügelmutter, Tube-Achse ³⁾	Centre lock fitting kit, 2-eared spinner - tube-axle ³⁾	1
F5VOAM	Radmutter	Wheel nut	16
F09CMGB-42	Radmutter chrom	Wheel nut chrome	16
F10MGB-42	Radzierring chrom 14" für Stahlfelge	Chrome ring 14" for steel wheel	4
F15SPT	Schlüssel für Achtkant-Zentralverschluß	Octagon wheel nut spanner	1
F16SPT	Speichenradschlüssel Messing	Octagon wheel nut spanner brass	1
F17SPT	Steckschlüssel Alu eloxiert für 8-Kant Mutter	Aluminium socket wheel, octagon wheel nut	1
F18SPT	Steckschlüssel für 2-Zack Flügelmutter	Socket wheel, 2-eared spinner	1
F19SPT	Kupfer-, Leder- Hammer	Copper hide hammer	1
F19MGB-42	Radkappe Rostyle	Hub cap rostyle	4
F20MGB/V8	Radkappen für V8-Felgen	Hub cap for V8 wheel	4
F21MGB-42	Radkappe frühe Stahlfelge	Hub cap early disc wheel	4
F27MGB-42	Radmutter Alu-Felge	Wheel nut alloy wheel	16
F28MGB-42	Radkappe zu Felge F26MGB-42	Hub cap to wheel no. F26MGB-42	4
F30SPT	Kupferpaste für Speichenradadapter 80 g	Copper lubrication for splines, 80 g	1
F50CMGB	Radkappen-Abzeichen Rostyle	Hub cap motif rostyle	4
F51VO	Radmutter Rostyle chrom + Minilite-Style-Radmutter zu Felge F50MGB	Wheel nut Rostyle chrome + Wheel nut „Minilite-style“ to wheel no. F50MGB	16
F52TR	Spurverbreiterungssatz 6 mm (Achssatz)	Wheel spacers 6 mm (axle kit)	A/R

**Hinweis
Note:**

auch lieferbar: 15" Aluräder (= MGA/MGC)

Also available: 15" alloy wheels (= MGA/MGC)

**Hinweis
Note:**

* 8tpi = Grobgewinde Nachrüstspeichenräder/Zentralverschluß
12tpi = Feingewinde für Fahrzeuge mit serienmäßigen
Speichenrad/Zentralverschlußausrüstung

* 8tpi = MGA converted to wire wheels/centre lock fitting
12tpi = all MGA original equipped with wire wheels/centre
lock fittings

- 1) Bitte Seite angeben
- 2) Satz = 4x Speichenrad/Zentralverschlußadapter,
4x Zentralverschlußmutter, benötigte Kleinteile und
Montageanleitung
- 3) Einzelne Speichenrad-/Zentralverschlußadapter auf
Anfrage

- 1) Please refer side
- 2) Kit = 4x wire wheel/centre lock adaptor, 4x centre
wheel nut, all required fitting parts + fitting description
- 3) Single wire wheel/centre lock adaptors on demand

Bremssättel- u. schein vorne

Front brake callipers & brake discs

No.	Bezeichnung	Description	Anzahl/Qty.
B1MGB	Bremssattel *)	Caliper *)	1/1
B2MGB	Kolben Bremszange	Piston caliper	4
B3TR2000	Rep.-Satz Bremssattel (für 2 Sättel)	Repair kit caliper (for 2 calipers)	1
B5MGB	Bremsbelag-Satz (beide Seiten)	Brake pad set (lh + rh)	1
B6MGB	Splint	Split pin	4
B6AMGB	Klammer Bremsbelag	Clip securing pads	4
B9SPT	Entlüftungsrippel	Bleed nipple	2
B11SPT	Befestigungsschraube Bremssattel	Bolt brake caliper	4
B12MGB	Sicherungsblech	Tab washer brake caliper	2
B14MGB	Bremsscheibe	Brake disc	2
B14MGB/R	Paar Bremsscheiben gelocht, geschlitzt	Pair grooved brake discs	1
B15MGB	Schmutzschild Bremsscheibe *)	Brake disc dust shield front *)	2
B16MGB	Befestigungsschraube Bremsscheibe zu Radflansch	Bolt disc to flange	8
ZK65SPT	Mutter 3/8" hochfest	Nut 3/8" reinforced	8

*) Bitte Seite angeben

*) Please refer side

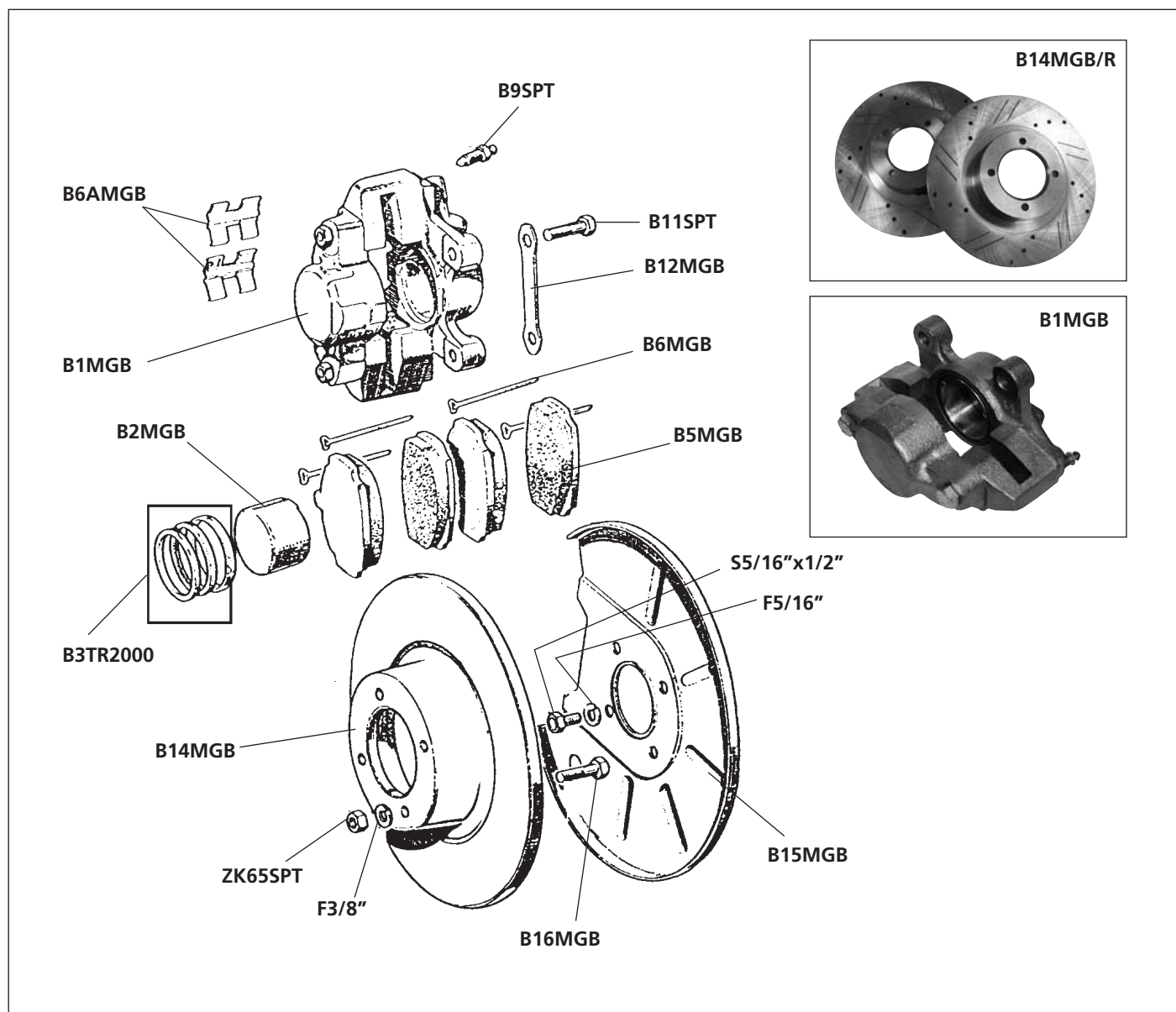

Handbremse

Handbrake

No.	Bezeichnung	Description	Anzahl/Qty.
B08MGB-22	Schalter Handbremse	Switch handbrake lever	1
B12MGB-22	Schraube Handbremse an Getriebe	Schraube, handbremse an getriebe	3
B13MGB-22	Klammer Handbrems-Seil	Clip handbrake cable	1
B14MGB-22	Kabeldurchführung	Cable grommet	1
B15BMGB-22	Handbrems-Seil Stahlfelge Tube-Axle 3-Synchro bis 65-67	Handbrake cable steel wheel Tube axle 3-synchro 65-67	1
B15CMGB-22	Handbrems-Seil Speichenfelge Tube Axle 3-Synchro bis 65-67	Handbrake cable wire wheel Tube axle 3-synchro 65-67	1
B15DMGB-22	Handbrems-Seil Stahlfelge Tube Axle 4-Synchro 67-74	Handbrake cable disc wheel Tube axle 4-synchro 67-74	1
B15EMGB-22	Handbrems-Seil Speichenfelge Tube Axle 4-Synchro 67-74	Handbrake cable wire wheel Tube axle 4-synchro 67-74	1
B15FMGB-22	Handbrems-Seil Stahlfelge Gummistoßst.-Modell 74-76 bis GHN/D5 415000	Handbrake cable disc wheel 74-76 rubber bumper model up to GHN/D5 415000	1
B15GMGB-22	Handbrems-Seil Speichenfelge Gummistoßst.-Modell 74-76 bis GHN/D5 415000	Handbrake cable wire wheel 74-76 rubber bumper model up to GHN/D5 415000	1
B15HMGB-22	Handbrems-Seil Stahlfelge Gummistoßst.-Modell ab 9.76 ab GHN/D5 415001	Handbrake cable disc wheel from 9.76 rubber bump. mod. from GHN/D5 415001	1
B15iMGB-22	Handbrems-Seil Speichenfelge Gummistoßst.-Modell ab 9.76 ab GHN/D5 415001	Handbrake cable wire wheel from 9.76 rubber bump. mod. from GHN/D5 415001	1
B23MGA-20	Handbrems-Seil Stahlfelge Banjo-Achse bis 66	Handbrake cable disc wheel banjo axle up to 66	1
B24MGA-20	Handbrems-Seil Speichenfelge Banjo-Achse bis 66	Handbrake cable wire wheel banjo axle up to 66	1
B26MGA-20	Handbrems-Ausgleichshebel innen	Handbrake compensator lever inner	1
B27MGA-20	Handbrems-Ausgleichshebel außen	Compensating lever outer	1
B28MGA-20	Lagerbolzen	Fulcrum bolt	1
B30MGA-20	Feder	Spring	1
B39MGA-20	Einstellmutter Handbrems-Seil	Adjusting nut handbrake cable	1
B43MGA-20	Buchse	Bush	1
B45MGA-20	Zwischenstück	Trunnion	1
SR50	Splint	Split pin	2
B69SPT	Lagerstift	Clevis pin	2

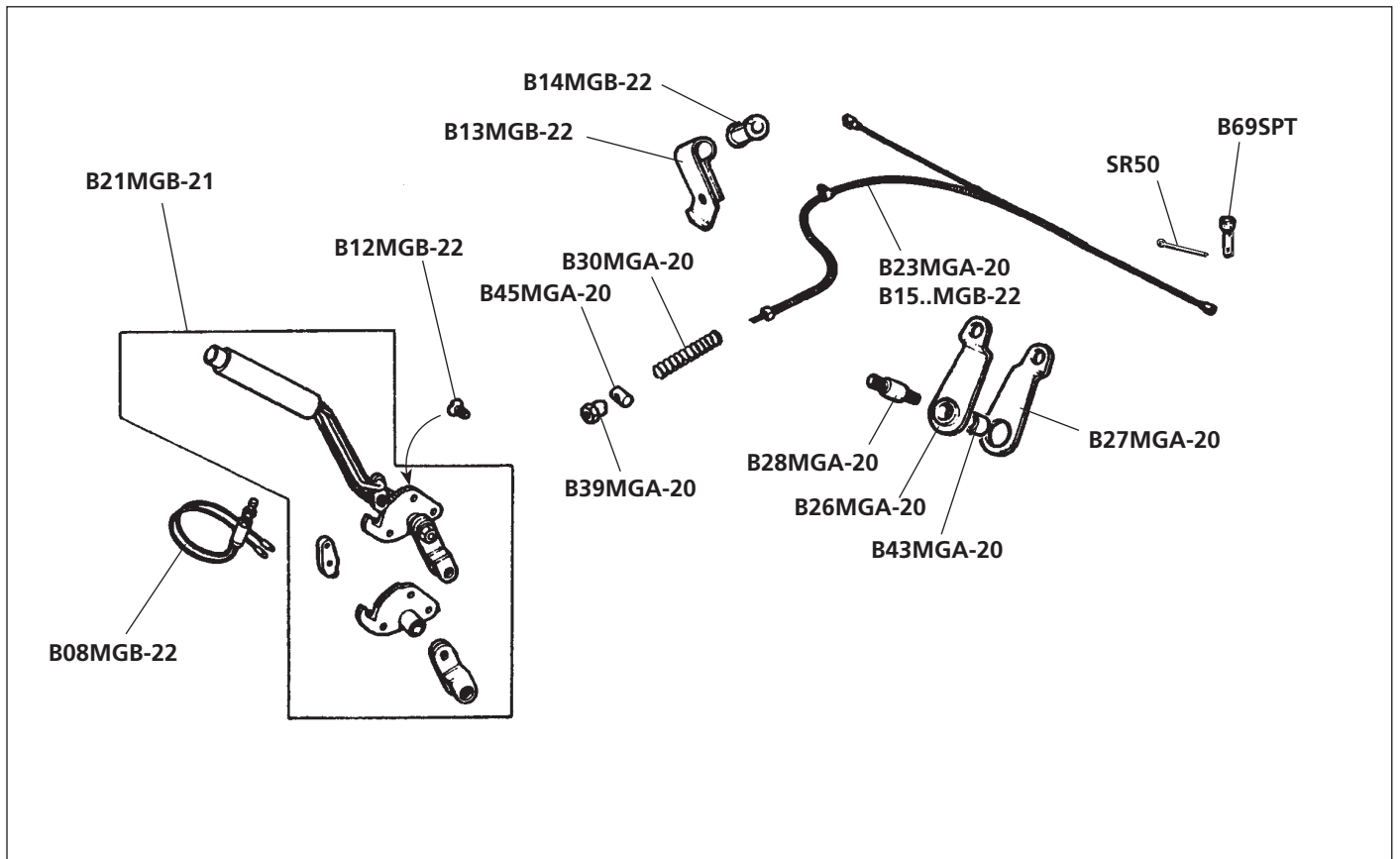

Bremsen hinten "Banjo"-Achse

Rear brakes "Banjo Axle"

No.	Bezeichnung	Description	Anzahl/Qty.
SR7	Senkkopfschraube Befestigung Bremstrommel - Stahlfelge	Countersunk screw drum brake - steel wheel	4
B9AMGB-21	Befestigungsmutter Bremstrommel - Speichenrad	Nut brake drum - wire wheel	8
B9ASPT	Abdeckkappe Entlüftungsschraube	Cap bleed screw	2
B10MGB-21	Einstell-Exzenter Bremse	Adjuster wheel cylinder	2
B11MGB-21	Rückholfeder Bremsbacken	Return spring brake shoes	2
B12MGB-21	Hebel Handbremse rechts 62-67 bis GHN3 123878	Handbrake lever rh 62-67 up to GHN3 123878	1
B12AMGB-21	Hebel Handbremse links 62-67 bis GHN3 123878	Handbrake lever lh 62-67 up to GHN3 123878	1
B14MGB-21	Gummi-Manschette Handbremshebel	Rubber gaiter handbrake lever	2
B15MGB-21	Klammer Radzylinder	Clip securing wheel cylinder	2
B19AMGB-21	Befestigungssatz Bremsbacken	Assembly kit brake linings	1
B20MGB-21	Entlüftungsschraube	Bleed screw	2
B21MGB-21	Rad-Bremszylinder ab 67 Roadster + alle GT	Wheel cylinder from 67 Roadster + all GT	2
B21MGB-5/8"	Radbremszylinder 5/8" zur Verringerung von Überbremsen auf der Hinterachse (für Motorsport)	Wheel cylinder 5/8" to reduce the brake pressure on the rear axle (for competition use)	2
B22MGB-21	Rep.-Satz Radbremszylinder	Repair kit wheel cylinder	1
B23MGB-21	Zugfeder Einstelllexzenter	Pull-off spring brake adj.	2
B23MGA-21	Stopfen Bremstrommel 1/2"	Plug drum brake 1/2"	2
B24MGA-21	Stopfen Bremstrommel 3/4"	Plug drum brake 3/4"	2
B24MGB-21	Zugfeder Radbremszylinder rechts	Spring pull wheel cylinder rh	1
B24AMGB-21	Zugfeder Radbremszylinder links	Spring pull wheel cylinder lh	1
B35MGB-21	Bremsbacken-Satz hinten (beide Seiten)	Brake shoes set rear (lh + rh)	1
B35MGB/RACE	Satz Competition Bremsbacken	Brake shoes set Competition	1
B42MGB-Banjo	Bremstrommel Banjo-Achse	Brake drum banjo axle	2
B46MGA-21	Schraube Bremsträgerplatte	Screw brake backplate	8
M3/8"	Mutter zu B46MGA-21	Nut to no. B46MGA-21	8
WZ101	Einstellschlüssel für Einstelllexzenter B10MGB-21	Tool for wheel cylinder adjuster no. B10MGB-21	1

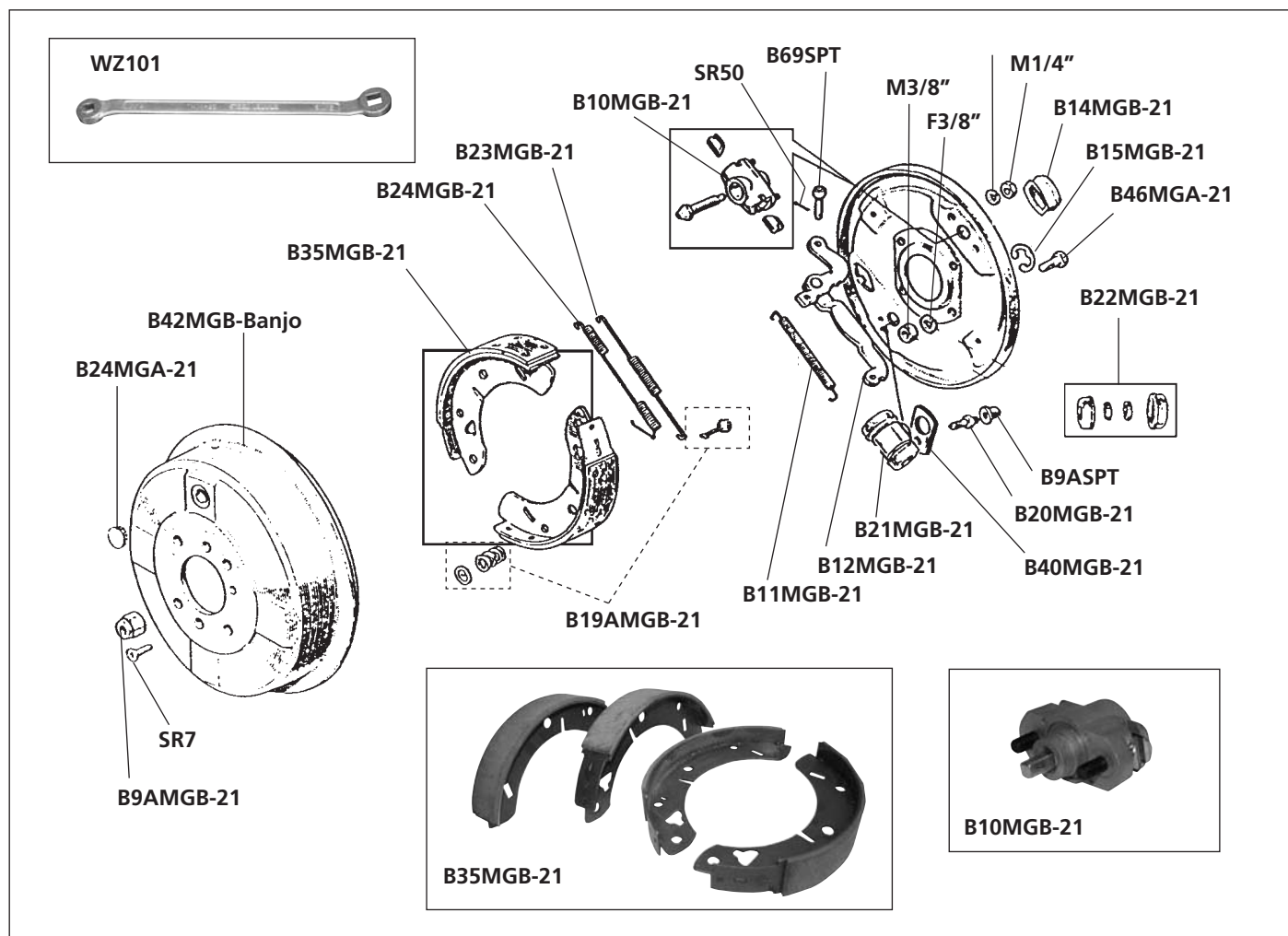

Bremse hinten "Tube"-Achse

Rear brakes "Tube Axle"

No.	Bezeichnung	Description	Anzahl/Qty.
SR7	Senkkopfschraube 1/4"x1/2"	Countersunk screw 1/4"x1/2"	4
B9AMGB-21	Befestigungsmutter Bremsstrommel - Speichenrad	Nut brake drum - wire wheel	8
B10MGB-21	Einstell-Exzenter Bremse	Adjuster wheel cylinder	2
B14MGB-21	Gummi-Manschette Handbremshebel	Rubber gaiter handbrake lever	2
B15MGB-21	Klammer Radbremszylinder	Clip	2
B19AMGB-21	Befestigungssatz Bremsbacken	Assembly kit brake linings	1
B21MGB-21	Rad-Bremszylinder ab 62 alle Roadster + GT 65-67	Wheel cylinder from 62 all roadster + GT 65-67	2
B21AMGB-21	Rad-Bremszylinder GT ab 68	Wheel cylinder GT from 68	2
B21MGB-5/18"	Radbremszylinder 5/8"	Wheel cylinder 5/8"	2
B22MGB-21	Rep.-Satz Radbremszylinder zu B21MGB-21	Repair kit wheel cylinder to no B21MGB-21	1
B22AMGB-21	Rep.-Satz Radbremszylinder zu B22BMGB-21	Repair kit wheel cylinder to no B22BMGB-21	1
B23MGB-21	Zugfeder Einstellexzenter	Pull-off spring brake adj.	2
B24MGB-21	Zugfeder Radbremszylinder rechts	Spring pull wheel cylinder rh	1
B24AMGB-21	Zugfeder Radbremszylinder links	Spring pull wheel cylinder lh	1
B30MGB-21	Zugfeder Handbremse	Pull-off spring handbrake	1
B31MGB-21	Hebel Handbremse rechts 67-78 GHN3 123879 bis GHN5 471641	Handbrake lever rh 67-78 GHN3 123879 up to GHN5 471641	1
B31AMGB-21	Hebel Handbremse links 67-78 GHN3 123879 bis GHN5 471641	Handbrake lever lh 67-78 GHN3 123879 up to GHN5 471641	1
B35MGB-21	Bremsbacken-Satz hinten (beide Seiten)	Brake shoes set rear (lh + rh)	1
B35MGB/RACE	Satz Competition Bremsbacken	Brake shoes set Competition	1
B40MGB-21	Dichtung Radbremszylinder	Gasket	2
B42MGB	Bremstrommel	Brake drum	2
B42AMGB	ALFIN-Bremstrommel	ALFIN brake drum	2
SR50	Splint	Split pin	2
B69SPT	Lagerstift	Clevis pin	2
WZ101	Einstellschlüssel für Einstellexzenter B10MGB-21	Tool for wheel cylinder adjuster no. B10MGB-21	1

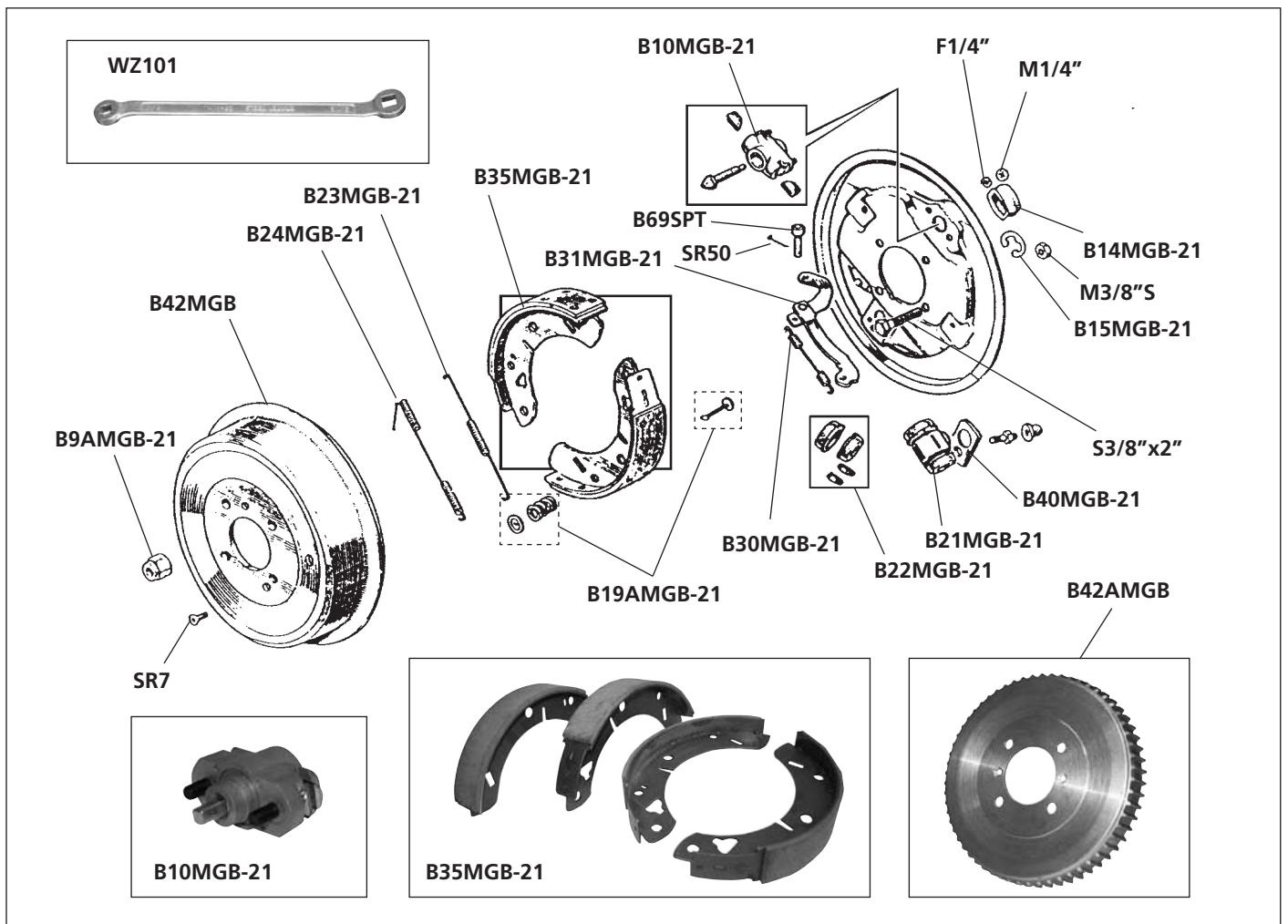

Hauptbremszylinder/Bremskraftverstärker

Brake master cylinder/ Brake booster

No.	Bezeichnung	Description	Anzahl/Qty.
B01MGB-20	Hauptbremszylinder 1-Kreis	Brake master cylinder single	1
B02MGB-20	Rep.-Satz Hauptzylinder 1-Kreis	Repair kit master cylinder single system	1
B08MGB-20	Hauptbremszylinder 2-Kreis	Brake master cylinder	1
B08AMGB-20	Hauptbremszylinder 2-Kreis (Servo)	Brake master cylinder dual (servo)	1
B09MGB-20	Rep.-Satz Hauptzylinder zu B08MGB-20	Repair kit master cylinder to no B08MGB-20	1
B09AMGB-20	Rep.-Satz Hauptzylinder zu B08AMGB-20	Repair kit master cylinder to no B08AMGB-20	1
B10MGB-20	Einfüllkappe Kunststoff für Hauptbremszylinder	Filler cap plastic	1
B11MGB-20	Bremsservo-Einheit 2-Kreis	Brake booster dual system	1
B11AMGB-20	Rep.-satz Bremskraftverstärker 2-Kreis	Repair kit brake booster dual	1
B12MGB-20	Rückschlagventil	On return valve	1
B14MGA-20	Rückhofeder Pedale	Return spring pedal	2
B15MGA-20	Lagerbuchse	Bearing bush	2
B18MGB-20	Dichtung	Seal	1
B19MGA-20	Pedalgummi	Pedal rubber	2
B21MGA-22	Kupferscheibe	Copper washer	1
B22MGA-22	Hohlschraube	Banjo bolt	1
B25MGB-20	Dichtung	Seal	1
C31MGB-20	Hohlschraube Verbindung	Banjo bolt union	1
B54TR	Unterdruckschlauch Bremskraftverstärker	Hose, vacuum	1
B69SPT	Lagerstift 5/16"	Clevis pin 5/16 "	1
B110	Bremskraftverstärker 1-Kreis	Brake booster single system	1

Bremsleitungen und -schläuche

Brake pipes & hoses

B19MGB-20	Bremslichtschalter mechanisch	Brake light switch mechanical	1
B20MGA-22	Sicherungsblech Bremsleitung	Locking plate brake pipe	3
B21MGA-22	Kupferscheibe	Copper washer	1
B22MGA-22	Hohlschraube	Banjo bolt	1
B24MGB-20	Bremsleitung-Verbinder 2-Kreis	Brake pipe connector double circuit	1
C31MGB-20	Hohlschraube Verbindung	Banjo bolt union	1
B40MGB-20	Bremsleitungssatz Kunifer *) Einkreis bis 10/74 LHD	Brake pipe set single circuit Kunifer *) up to 10/74 LHD	1
B41MGB-20	Bremsleitungssatz Kunifer *) Einkreis 6/75-77 LHD	Brake pipe set single circuit Kunifer *) 6/75-77 LHD	1
B42MGB-20	Bremsleitungssatz Kunifer *) Zweikreis LHD mit Servo	Brake pipe set double circuit Kunifer *) LHD + servo	1
B43MGB-20	Bremsleitungssatz Kunifer *) Zweikreis LHD ohne Servo	Brake pipe set double circuit Kunifer *) LHD no servo	1
B58B	Kontermutter Bremsschlauch	Nut brake hose	3
B58C	Kupferscheibe Bremsschlauch	Copper washer brake hose	3
B58D	Zahnscheibe	Washer star	3
B59MGB	Bremsschlauch vorne bis 74 (Chromstoßstangenmodell)	Brake hose front up to 74 (Chrome bumper model)	2
B59AMGB	Bremsschlauch vorne ab 75 (Gummistoßstangenmodell)	Brake hose front from 75 (Rubber bumper model)	2
B60MGB	Bremsschlauch hinten	Brake hose rear	1
B64ASPT	5-Fach-Verteiler (Einkreis-Anlage)	Union brake pipes 5-way	1
B65SPT	Verteiler 3-Fach Bremsleitung	Union brake pipes 3-way	1
B80	Messing-Bremsleitungs-Ende (Außengewinde 3/ 8" UNF)	Brake pipe nut female brass (inner thread 3/8" UNF)	A/R
B81	Messing-Bremsleitungs-Ende (Überwurfmutter Innengewinde 3/8" UNF)	Brake pipe nut male brass (outer thread 3/8" UNF)	A/R
B95	3/16" Bremsleitung Kunifer *), pro Meter	3/16" Brake pipe Kunifer *), per meter	A/R
E108H	Bremslichtschalter hydraulisch gesteckt	Stop light switch (Lucar type)	1
E108TR3	Bremslichtschalter hydraulisch geschraubte Anschlüsse	Stop light switch (screw type)	1

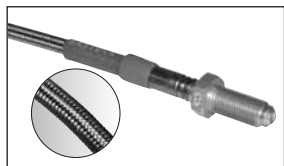
**Stahlmantelte Bremsschläuche
– mit TÜV-Gutachten!**

- Super Optik härterer
- Pedaldruck kürzerer
- Pedalweg

**Steel coated brake hoses – with TÜV
Approval!**

- perfect finish
- improved pedal feeling
- less pedal travel



B59MGBAQ	Bremsschlauch stahlmantelt vorne - mit TÜV-Gutachten	Steel coated brake hose front - with TÜV-approval	2
B60MGBAQ	Bremsschlauch stahlmantelt hinten - für Sportzwecke	Steel coated brake hose rear reinforced -for competition use	1
B200MGB	Satz Bremsschläuche stahlmantelt, 3-teilig - mit TÜV-Gutachten	Set steel coated brake hoses (3 pieces) - with TÜV-approval	1

BR	Bremsflüssigkeit 0,5 l	Brake fluid 0,5 l	A/R
BRBR	Hochleistungsbremsflüssigkeit "Blue Race" von ATE, pro Liter	High performance brake fluid ATE "Blue Race", per liter	A/R
BRSi05	Silikonbremsflüssigkeit 0,5 Liter	Silicone brake fluid 0,5 liter	A/R
BRSi1	Silikonbremsflüssigkeit 1 Liter	Silicone brake fluid 1 liter	A/R

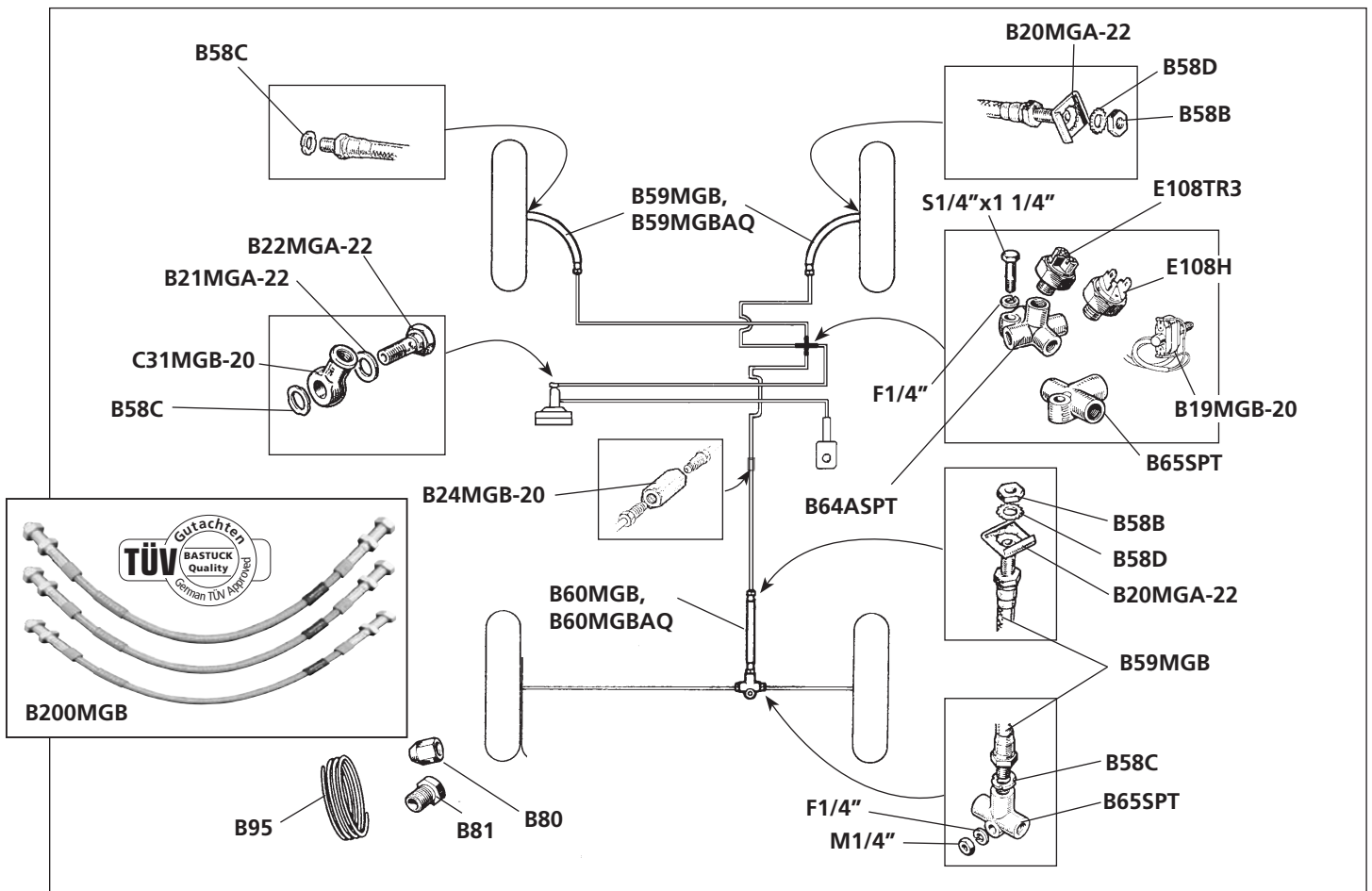
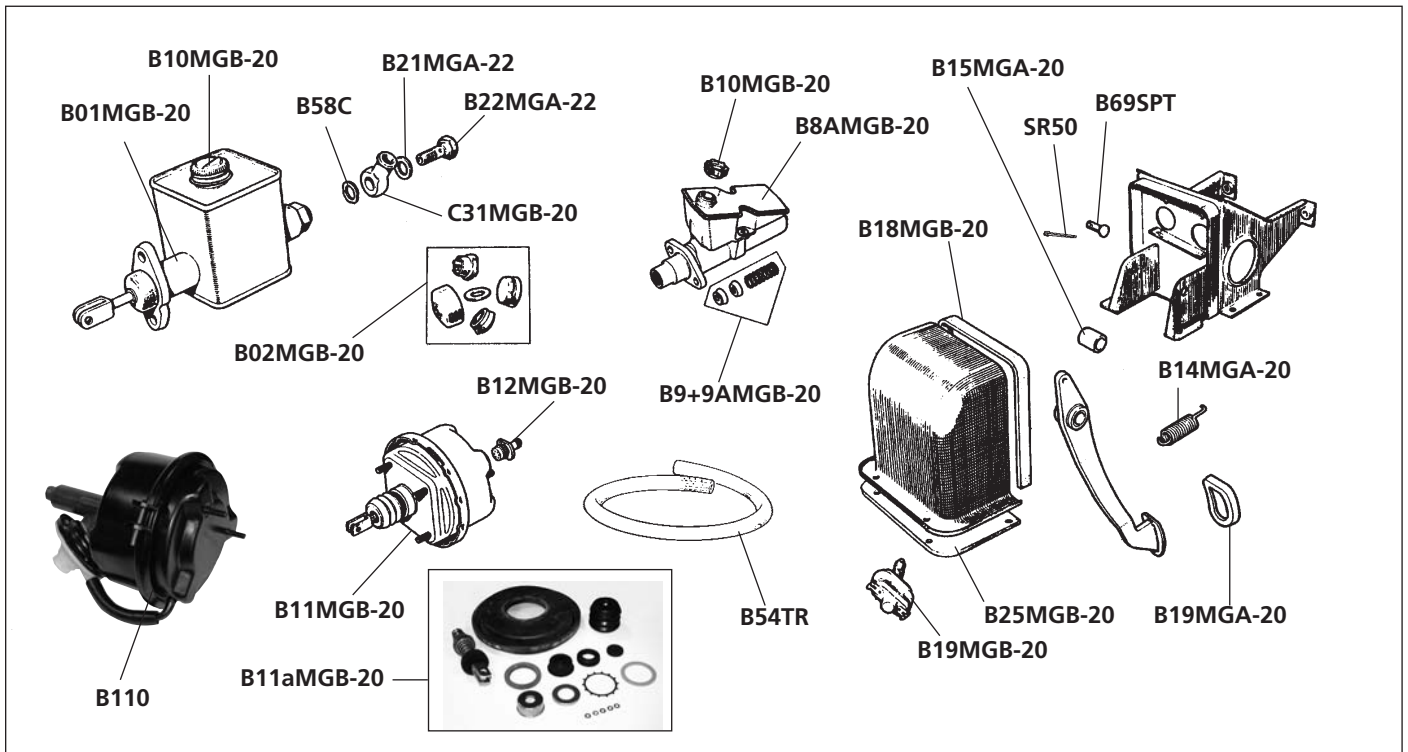

Hinweis
Note:



*) Kunifer = Korrosionsbeständige Kupfer-Messing-Legierung. Die Bremsleitungen werden mit Messingverschraubungen geliefert.

*) Kunifer-brake pipe tubing and. Made from non corroding cupro nickel with lifetime guarantee on anti corrosion. kunifer brake pipe tubing and brass tube nuts.

No.	Bezeichnung	Description	Anzahl/Qty.
E1TR6	Unterbrecherkontakt	Contact set	1
E1SPT1500	Unterbrecherkontakt	Contact set	1
E2TR4	Verteilerfinger	Rotor arm	1
E2SPT1500	Verteilerfinger	Rotor arm	1
E3TR6	Kondensator	Condenser	1
E3SPT1500	Kondensator	Condenser	1
E4H	Verteilerkappe 25D Ausgang oben	Distributor cap 25D top push	1
E4SPT1500	Verteilerkappe Typ 45D	Distributor cap type 45D	1
E6TR4	Zündkabel-Satz geschraubt für E11MGA-29	Spark plug lead set srewed for no. E11MGA-29	1
E6SPT	Zündkabel-Satz gesteckte Kabel	Spark plug lead set	1
E8MGB	Zündverteiler 45D4, 62-74 neu *)	Distributor 45D4, 62-74 new *)	1
E8AMGB	Zündverteiler 45D4, ab 75 neu	Distributor 45D4, from 75 new	1
E8ATR	Verteilerfeder für 25D + 45D4 Verteiler	Distributor spring for distributor type 25D + 45D4	1
E8BTR	O-Ring Verteilersockel	O-ring oil seal distributor	1
E9TR6	Verteiler-Stecker +Kabel	Connector +lead LT	1
E11MGA-29	Verteilerkappe 25D Ausgang seitlich	Distributor cap 25D side push	1
E12SPTMK4	Zündspule ab 75	Ignition coil from 75	1
E12SPTMK3	Zündspule Zündkabel gesteckt bis 74	Ignition coil push on connector up to 74	1
E13SPTMK4	Zündkerze	Spark plug	4
E14TR4	Kabel Motor an Karosserie	Lead earth strap to body	1
E15SPT	Plus-Klemme Batterie	Battery clamp (+) plus	1
E16SPT	Minus-Klemme Batterie	Battery clamp (-) minus	1
E16/T	Batterie Trennschalter für Minus-Polanschluß	Battery isolator negative pole connector	1
E16MGB-23	Unterdruck-Leitung Metall	Vacuum pipe ignition	1
E17	Unterdruck-Leitung Kunststoff mit Verbindungsstecker	Plastic vacuum pipe with connecting plug	1
E23MGA-33	Kabel Batterie Plus an Masse	Lead battery to positive earth	1
E26MGA-33	Kabel Magnetschalter an Anlasser	Lead solenoid to starter	1
E27MGA-33	Kabel Batterie an Magnetschalter	Lead battery to solenoid	1
E61AH	Batteriehalterahmen 6V	Bracket, battery 6V	2
E66MGB-23	Batteriekabel-Verbindung zw. beiden 6 Volt Batterien	Lead battery link	1
E68MGB-23	Kabel Batterie an Minus an Masse	Lead battery to negative earth	1
E70MGB-23	Kabel Magnetschalter an Anlasser	Lead solenoid to starter	1
E70AH	Batterie trocken 6V	Battery 6-volt, dry charged	2
E70AH/D	Hochleistungsbatterie trocken 6V	High Performance battery, dry charged	2
S90MGB/6V	Batteriehalteset für 6V Batterie, bis 1974	Battery packing set, for 6 volts batterie, to 1974	2
S90MGB/12V	Batteriehalteset für 12V Batterie, ab 1974	Battery packing set, for 12 volts batterie, from 1974	1

*) als Ersatz für den nicht mehr lieferbaren 25D Verteiler

*) to replace the not longer available distributor type 25D

Verteiler / Distributor Lucas 25D

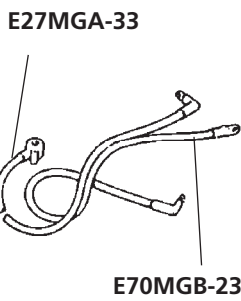
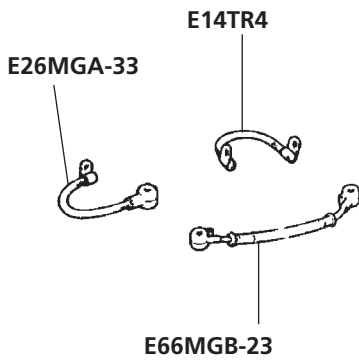
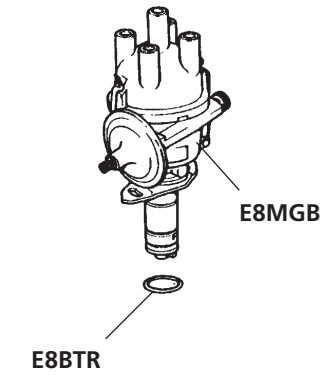
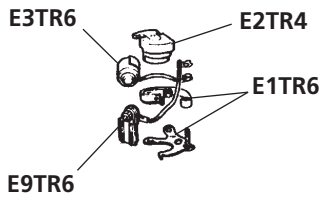
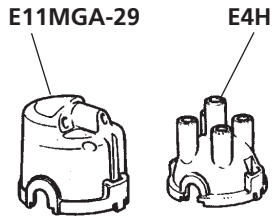

S90MGB/..

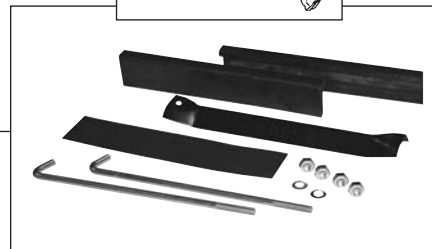

Verteiler / Distributor Lucas 45D4

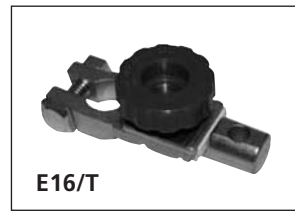
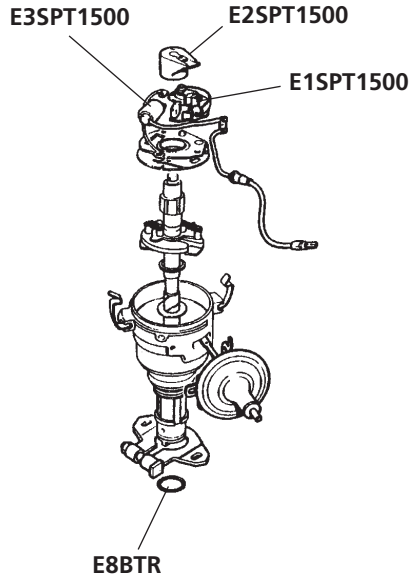
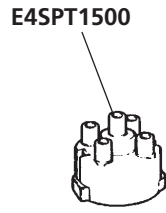

E16MGB-23

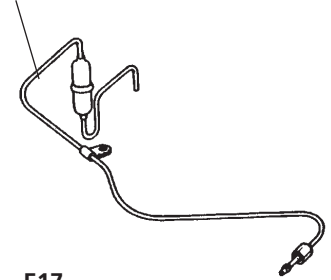

E6SPT

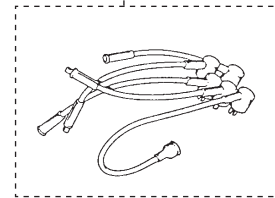

E8ATR

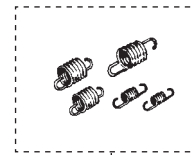

E12SPT

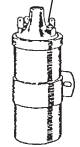

E15SPT



E13SPTMK4



E61AH

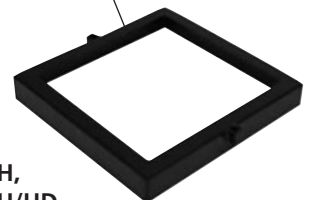

E70AH,
E70AH/HD



No.	Bezeichnung	Description	Anzahl/Qty.
K18MGA-914	Keilriemen für Lichtmaschine E310COMP	V-belt to high performance AC alternator no. E310COMP	1
E40MGB	Relais Overdrive/Hupen/Zündung	Relay overdrive-/horn/ignition	A/R
E40AMGB-23	Anlasser-Relais ab 76	Starter relay from 76	1
E44MGA-34	Abdeckkappe Batteriekabel Magnetschalter	Boot cover battery lead to solenoid	1
E105SPT	Blinkrelais (2 Stecker)	Flasher unit (2 plugs)	1
E106SPT	Warnblinkrelais/Blinkrelais (3 Stecker)	Hazard/Flasher unit (3 plugs)	1
E303TR4	Anlasser-Kohlen-Satz 3-Synchro für E300AMGB	Starter motor brushes set 3-synchro for no. E300AMGB	1
E303TR6	Anlasser-Kohlen-Satz keilförmig 4-Synchro für E300MG	Starter motor brushes set triangle shape 4-synchro for E300MGB	1
E300AMGB	AT-Anlasser früh 3-Synchro	Exch. starter motor 3-synchro	1
E300MGB	AT-Anlasser spät 4-Synchro	Exch. starter motor 4-synchro	1
E300MGBRACE	Hochleistungsgetriebeanlasser 4-Synchro Getriebe	High performance starter motor 4-synchro gearbox	1
E300AMGBRACE	Hochleistungsgetriebeanlasser 3-Synchro Getriebe	High performance starter motor 3-synchro gearbox	1
E305SPT	Anlasser-Magnetschalter mit Startknopf früh	Switch starter solenoid with start knob early	1
E306SPT	Anlasser-Magnetschalter ab 66	Switch starter solenoid from 66	1
E310SPT	Lichtmaschine 16ACR	AC alternator 16ACR	1
E310MGB	Lichtmaschine 18ACR *) - bitte Hinweis beachten!	AC alternator 18ACR *) - please pay attention to our note !	1
E310CSPT	Stecker Lichtmaschine	Conversion kit, socket	1
E310ASPT	Lüfterrad	Fan	1
E310BSPT	Riemenscheibe	Pulley, alternator	1
E310COMP	Hochleistungslichtmaschine Drehstrom (40 Amp.) inkl. Riemenscheibe	High performance AC alternator (40 Amp/12V) incl. pulley	1
E310BRKT-MGA	Haltesatz für E310COMP (für MGB) *)	Fitting kit for E310COMP (for MGB) *)	1
E310ACOMP	Keilriemenscheibe Aluminium Ø 110 mm für Sportzwecke für Lichtmaschine E310COMP	Dynamo pulley alloy Ø 110 mm for competition use for AC alternator E310COMP	1
E311SPT	Satz Kohlen Lichtmaschine	Brush set dynamo	1
E320SPT	Gleichstrom-Lichtmaschine Typ C40	Dynamo Type C40	1
E321SPTA	Keilriemenscheibe Aluminium Ø 110 mm für Sportzwecke für Lichtmaschine E320SPT, E310SPT, E310MGB	Dynamo pulley alloy Ø 110 mm for competition use for AC alternator E320SPT, E310SPT, E310MGB	1
E322SPT	Kohlen-Satz Lichtmaschine Gleichstrom	Brush set dynamo	1
E326SPT	Regler Lichtmaschine	Conrol box	1
E410SPT	Sicherungskasten (2 Sicherungen)	Fuse box (2 fuses)	1
E410TR6	Sicherungskasten 4 Sicherungen	Fuse box 4 fuses	1
E411TR6	Deckel Sicherungskasten 4 Sicherungen	Cover fuse box 4 fuses	1
E415SPT.	Glas-Sicherung - bitte Amperezahl angeben	Fuse glas - please refer amp.	A/R
E420SPT	Fliegende Sicherung	Fuse/holder (in-line)	A/R

*) Abb. ähnlich - entspricht nicht dem Original

*) Illustration similar -shows not original

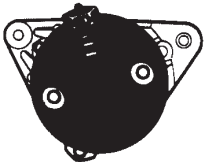

Hinweis 

Note:

A) Stecker Lichtmaschine E310SPT/E310MGB
 B) Stecker MGB mit 18ACR Lichtmaschine 1975-78;
 bitte Stecker E310CSPT mitbestellen und Kabelbaum
 entsprechend umbauen!

A) Terminal for AC alternator E310SPT/E310MGB
 B) Terminal MGB equipped with 18ACR AC alternator
 1975-78; Please order terminal E310CSPT to replace
 original unit and convert wiring loom!

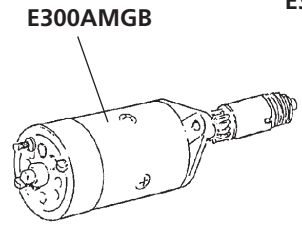
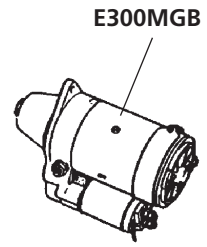
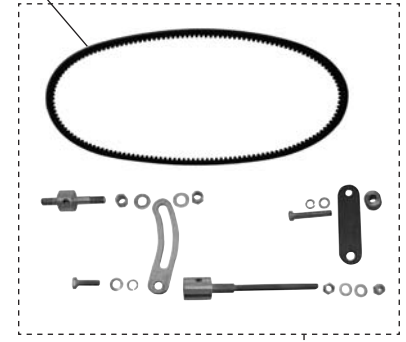
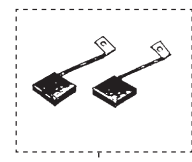
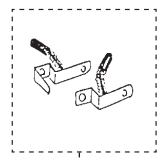
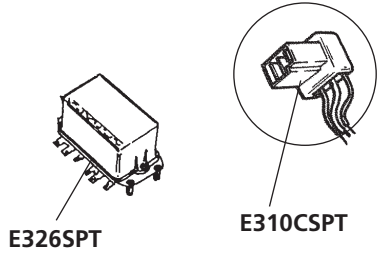
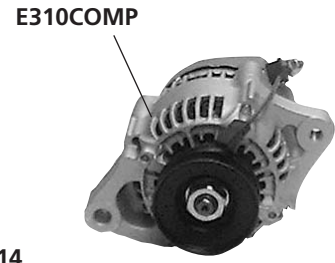
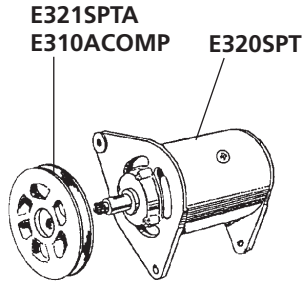
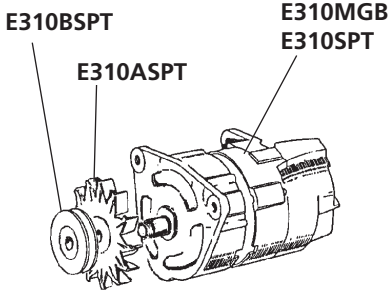

E310BRKT-MGA

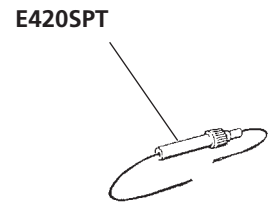
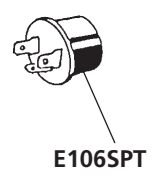
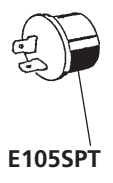
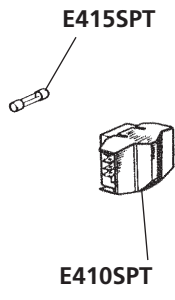
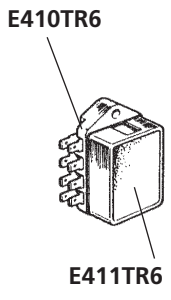
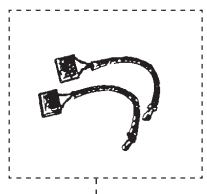
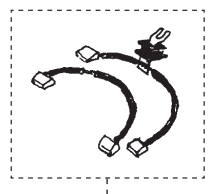
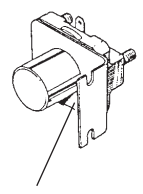
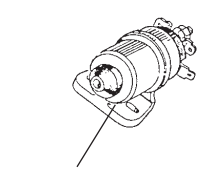
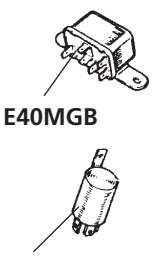

No.	Bezeichnung	Description	Anzahl/Qty.
E104MGB	Türkontaktschalter Innenbeleuchtung	Switch courtesy light	2
E105MGB	Kontaktschalter Kofferraumbeleuchtung	Switch boot light	1
E105TR6	Kontaktschalter Kofferraumbeleuchtung Heckklappe	Switch boot light / boot lid	1
E109TR6	Dimmschalter Armaturenbrettbeleuchtung	Panel reostat switch	1
E109MGB	Drehknopf zu E109TR6	Switch knob to no. E109TR6	1
E116SPT	Warnblinkanlage Universal zum Nachrüsten	Hazard warning unit	1
E120MGB	Lenkradschloss bis 76	Steering lock up to 76	1
E120AMGB	Lenkradschloss ab 76 ab GNH/D5 410001	Steering lock from GNH/D5 410001 from 76 on	1
E120SPTMK3	Zündungs/Anlasser-Schalter	Ignition +starter switch	1
E121MGB	Abreisschraube Lenkradschloss	Shear head bolt steering lock	1
E121SPTMK3	Schlosseinsatz und Schlüssel	Ignition barrel and key	1
E122MGB	Elektroteil Lenkradschloss bis 76	Switch ignition steering lock up to 76	1
E122AMGB	Elektroteil Lenkradschloss ab 76	Switch ignition steering lock from 76 on	1
E123SPT	Anlassertaste	Starter knob	1
E129SPT	Fußschalter Fernlicht	Foot dipping switch	1
E129MGB	Overdrive-Schalter	Overdrive switch	1
E129AMGB	Overdrive Schalter Abdeckung	Plate overdrive switch	1
E413SPT	Zigarettenanzünder	Cigaret lighter	1
E413SPTCHROM	Zigarettenanzünder mit Chromknopf	Cigaret lighter with chrome knob	1
E435SPT	Satz Hupen Hoch- und Tiefton (Zubehör)	Horn kit, high and low note	1

Schalter an Lenksäule (LHD)**Switches steering column (LHD)**

E130MGB	Blinkerschalter 62-67	Switch indicator 62-67	1
E131MGB	Blinkerschalter mit Hupe ab 68 bis 219000	Switch/horn indicator from 68 up to 219000	1
E132MGB	Blinkerschalter ab 219001 bis Roadster 267109 / bis GT 267332	Switch indicator from 219001 to Roadster 267109 / to GT 267332	1
E133MGB	Blinkerschalter Roadster ab 267100 bis 328100, GT ab 267333 bis 328000	Switch indicator Roadster from 267100 to 328100, GT from 267333 to 328000	1
E134MGB	Blinkerschalter bis 76 Roadster ab 328101 / GT ab 328801	Switch indicator up to 76 Roadster from 328101 / GT from 328801	1
E135MGB	Blinkerschalter mit Hupe ab 77 ab GHN/D5 410001	Switch/horn indicator from 77 from GHN/D5 410001	1
E140MGB	Schalter Scheibenwischer/Overdrive 68-73 Roadster bis 328100, GT bis 328800	Switch wiper/overdrive 68-73 Roadster to 328100, GT to 328800	1
E141MGB	Schalter Scheibenwischer/Overdrive 73-76 Roadster bis 328101, GT bis 328801	Switch wiper/overdrive 73-76 Roadster to 328101, GT to 328801	1
E142MGB	Schalter Scheibenwischer ab 77 ab GHN/D5 410001	Switch wiper ab 77 from GHN/D5 410001 on	1

**Schalter Armaturenbrett 1962-71
- bis GHN/D5 258000****Switches instrument panel 1962-71
- up to GHN/D5 258000**

E18MGA-35	Abdeckung Kartenleselampe	Cover map light	1
E18AMGA-35	Dichtung unter Kartenleselampe	Rubber	1
E19MGA-35	Lampenglas Kartenleselampe	Lens map light (glass)	1
E109TR6	Dimmerschalter	Control, panel light	1
E109MGB	Knopf für Dimmerschalter	Knob (control)	1
E126SPT	Schalter Kartenleselampe	Switch map light	1
E126MGB	Knopf für Schalter Kartenleselampe	Knob (map light switch)	1
E129MGB	OD-Schalter	Switch overdrive	1
E129AMGB	Abdeckung OD-Schalter	Escutcheon, OD switch	1
E145MGB	Kippschalter (63-65)	Switch (toggle)	1
E141TR3	Lichtschalter (Ziehen/Drehen) 66-67	Switch light (push/pull) 66-67	1
E141AMGB	Knopf für Lichtschalter	Knob, light switch	1
E142AMGB	Scheibenwischerschalter (1-stufig)	Switch, single speed wiper	1
E142BMGB	Scheibenwischerschalter (2-stufig)	Switch, two speed wiper	1
E143MGB	Schalter - Overdrive (früh) - Heizungsgebläse - Nebelschlußleuchte	Switch - overdrive (early) - heater motor - fog/spot	1
E144MGB	Schalter heizbare Heckscheibe	Switch heated rear window	1

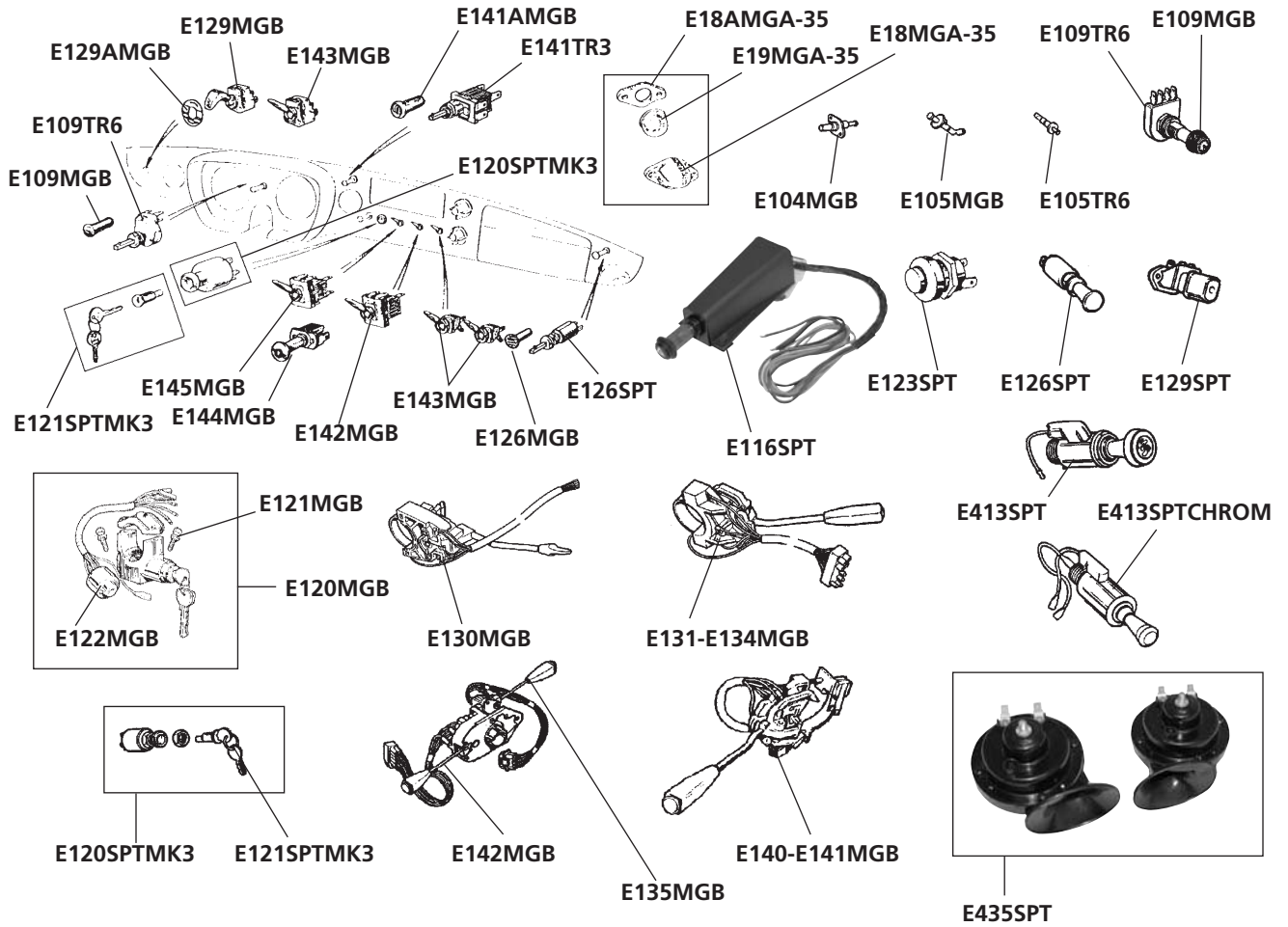

Schalter Armaturenbrett / Switches instrument panel 1972-76 bis / up to GHN/D5 410000

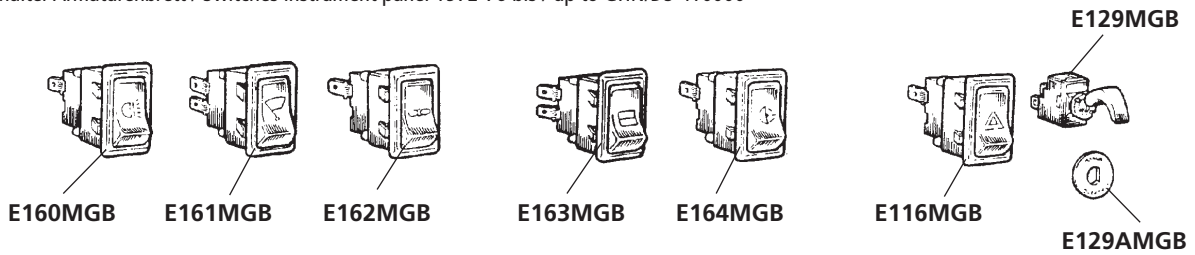

Schalter Armaturenbrett / Switches instrument panel ab / from 1976 ab / from GHN/D5 410001

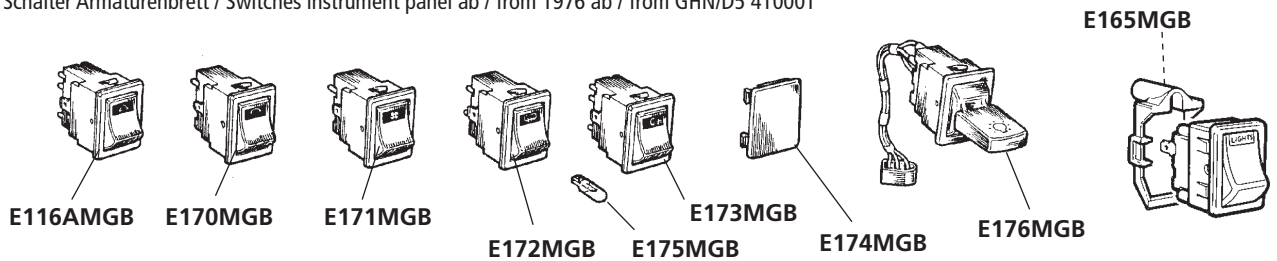

Kontrollleuchten / Warning lamps

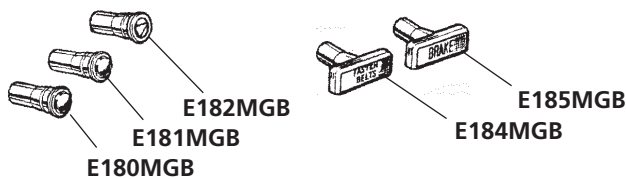

Schalter Armaturenbrett 1972-76

Switches instrument panel 1972-76

No.	Bezeichnung	Description	Anzahl/Qty.
E116MGB	Warnblinkschalter	Switch hazard warning	1
E116MGB/USA	Warnblinkschalter USA mit Chromrand 1973-76	Switch hazard warning US models with chrome ring 1973-76	1
E160MGB	Lichtschalter	Switch lights	1
E160MGB/USA	Lichtschalter USA mit Chromrand	Switch lights US models with chrome ring	1
E161MGB	Wischerschalter	Switch wipers	1
E162MGB	Schalter Heizungsgebläse	Switch heater fan	1
E162MGB/USA	Schalter Heizungsgebläse USA	Switch heater fan, US models	1
E163MGB	Schalter heizbare Heckscheibe	Switch heated rear window	1
E164MGB	Zusatzschalter für versch. Funktionen	Switch auxiliary equipment	1

Schalter Armaturenbrett ab 1976

Switches instrument panel 1976 on

E116AMGB	Warnblinkschalter	Switch hazard warning	1
E165MGB	Halter für beleuchtete Schalter	Holder for light switch	1
E170MGB	Schalter Innenbeleuchtung	Switch interior lamp	1
E171MGB	Schalter Heizungsgebläse	Switch heater fan	1
E172MGB	Schalter heizbare Heckscheibe	Switch heated rear window	1
E173MGB	Schalter Nebenschlußleuchte	Switch rear fog lamp	1
E174MGB	Verschlußdeckel	Blanking plate	1
E175MGB	Birne Schalterbeleuchtung	Bulb, switch illumination	A/R
E176MGB	Lichtschalter	Switch lights	1

Schalter Armaturenbrett USA 1968-71

Switches instrument panel US model 1968-71

E150MGB/USA	Lichtschalter mit Chromrand	Switch lights with chrome ring	1
-------------	-----------------------------	--------------------------------	---

Schalter Armaturenbrett USA 1972-76

Switches instrument panel US model 1972-76

E116MGB/USA	Warnblinkschalter mit Chromrand 1972	Switch hazard warning with chrome ring 1972	1
E116MGB/USA72	Warnblinkschalter mit Chromrand 1973-76	Switch hazard warning with chrome ring 1973-76	1

Kontrollleuchten

Warning lamps

E180MGB	Kontrollleuchte Rot (Zündung)	Warning lamp ignition, red	1
E181MGB	Kontrollleuchte Blau (Fernlicht)	Warning lamp main beam, blue	1
E182MGB	Kontrollleuchte Grün (Blinker)	Warning lamp indicators, green	1
E184MGB	Warnleuchte Gurt	Warning lamp seat belt	1
E185MGB	Warnleuchte Handbremse	Warning lamp handbrake	1

E190MGB	Schalterabdeckung MGB Linksklenker 1962-74 bis GHN/D5360300	Cowl MGB LHD models 1962-74 to GHN/D5360300	1
---------	---	---	---

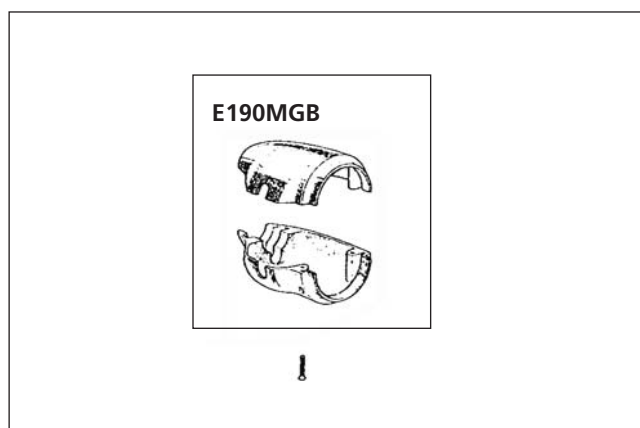

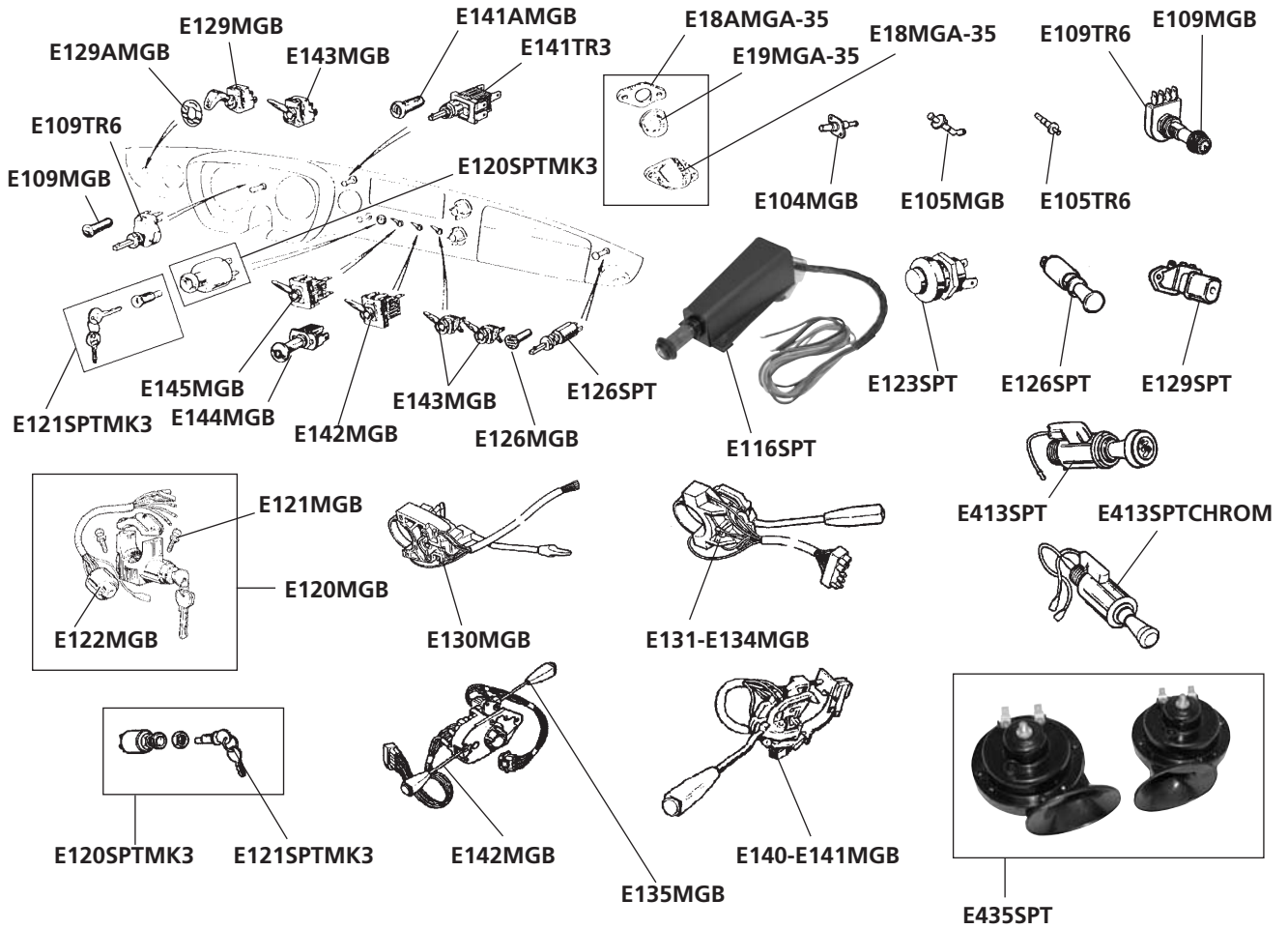

Schalter Armaturen Brett / Switches instrument panel 1972-76 bis / up to GHN/D5 41000

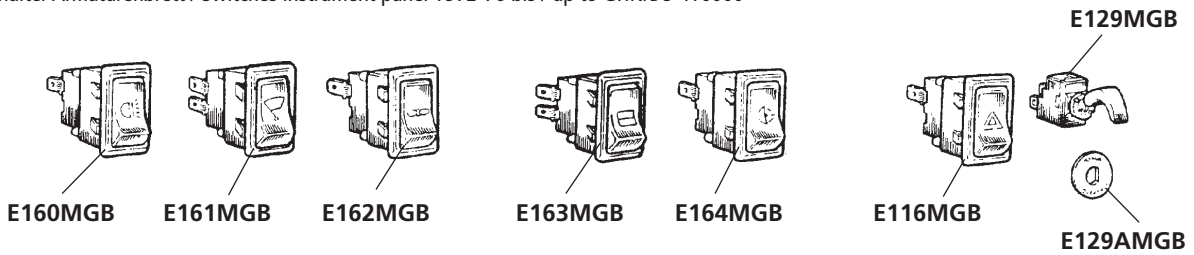

Schalter Armaturen Brett / Switches instrument panel ab / from 1976 ab / from GHN/D5 41001

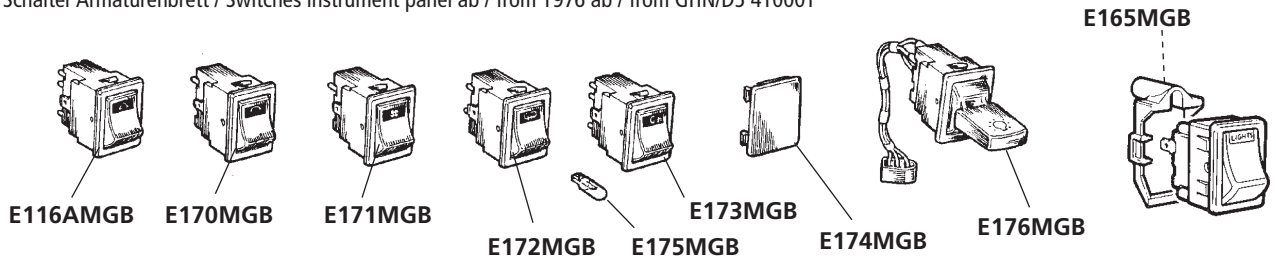

Kontrollleuchten / Warning lamps

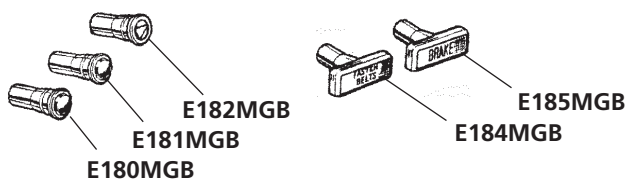

Kabelbäume Roadster LHD *)

Wiring Harness Roadster LHD *)

No.	Bezeichnung	Description	Anzahl/Qty.
E400MGB	Hauptkabelbaum '62-67, "Plus" an Masse, Jaeger Instrumente	Main harness '62-67, "Plus" to earth, Jaeger instruments	1
E400AMGB	Hauptkabelbaum '62-67, "Plus" an Masse, Smith Instrumente	Main harness '62-67, "Plus" to earth, Smith instruments	1
E401MGB	Hauptkabelbaum '68 (138401-158209), Lichtmaschine mit separater Reglerbox	Main harness '68 (138401-158209), AC alternator with separate control box	1
E401AMGB	Kabelbaum hinten für E401MGB	Rear harness for E401MGB	1
E402MGB	Hauptkabelbaum '69 (158210-187210), Lichtmaschine mit integrierter Reglerbox	Main harness '69 (158210-187210), AC alternator with integral control box	1
E401AMGB	Kabelbaum hinten für E402MGB	Rear harness for E402MGB	1
E403MGB	Hauptkabelbaum '70 (187211-21900), "Hupenbetätigung am Blinkerhebel"	Main harness '70 (187211-21900), "horn control on indicator stalk"	1
E403AMGB	Kabelbaum hinten für E403MGB	Rear harness for E403MGB	1
E404MGB	Hauptkabelbaum '71 (219000-258000), "Hupenbetätigung in Lenkradmitte"	Main harness '71 (219000-258000), "horn control in centre of steering wheel"	1
E404AMGB	Kabelbaum hinten für E404MGB	Rear harness for E404MGB	1
E405MGB	Hauptkabelbaum '72 (258001-294250), "mit Radiovorbereitung"	Main harness '72 (258001-294250), "introduction of radio"	1
E404AMGB	Kabelbaum hinten für E405MGB	Rear harness for E405MGB	1
E406MGB	Hauptkabelbaum '73 (294251-328100), "RVC Tacho"	Main harness '73 (294251-328100), "RVC Tachometer"	1
E406AMGB	Kabelbaum hinten für E406MGB	Rear harness for E406MGB	1
E406BMGB	zusätzlicher Kabelbaum für E406MGB	Additional harness for E406MGB	1
E407MGB	Hauptkabelbaum '74 (328101-360300), mit Warnblinker	Main harness '74 (328101-360300), hazard warning lights	1
E407AMGB	Kabelbaum hinten für E407MGB	Rear harness for E407MGB	1
E407BMGB	zusätzlicher Kabelbaum Armaturentafel für E407MGB	Additional harness instrument panel	1
E408MGB	Hauptkabelbaum '75+76 (360301-410000), frühe Gummistoßstangenmodelle + OD-Schalter an Lenksäule	Main harness '75+76 (360301-410000), early rubber bumper models with column stalk OD-switch	1
E408AMGB	Kabelbaum hinten für E408MGB	Rear harness for E408MGB	1
E407BMGB	zusätzlicher Kabelbaum Armaturentafel für E408MGB	Additional harness instrument panel for E408MGB	1
E409MGB	Hauptkabelbaum '77+78 (410001-471000), OD-Schalter an Schaltknopf	Main harness '77+78 (410001-471000), OD-Switch on gear knob	1
E408AMGB	Kabelbaum hinten für E409MGB	Rear harness for E409MGB	1
E409BMGB	zusätzlicher Kabelbaum Armaturentafel für E409MGB	Additional harness instrument panel for E409MGB	1
E410MGB	Hauptkabelbaum '79-80 (471001-511519), mit Nebelschlußleuchte	Main harness '79-80 (471001-511519), rear fog lamps fitted	1
E410AMGB	Kabelbaum hinten für E410MGB	Rear harness for E410MGB	1
E411MGB	Hauptkabelbaum ab Mitte '80 (ab 511520)	Main harness from June '80 (511520 on)	1
E410AMGB	Kabelbaum hinten für E411MGB	Rear harness for E411MGB	1

**Hinweis
Note:**

*) Alle Kabelbäume für Linkslenker (LHD) Rechtsgelenkte Fahrzeuge (RHD) auf Anfrage/Bestellung!
Alle Kabelbäume aus Gründen der einfacheren Nachrüstung von zusätzlichen Verbrauchern (Warnblinker, Radio..) PVC ummantelt. Stoffummantelte Kabelbäume auf Anfrage.

*) All wiring harnesses for LHD models - RHD models on request! For easy fitting of additional equipment (warning hazard, radio..) the wiring harnesses are PVC.
Original cloth harness on demand!

Kabelbäume GT-Modelle LHD *)

Wiring Harness GT Models LHD *)

No.	Bezeichnung	Description	Anzahl/Qty.
E401MGB	Hauptkabelbaum '68 (GT 139471-158209), Lichtmaschine mit separater Reglerbox	Main harness '68 (139471-158209), AC alternator with separate control box	1
E412MGBGT	Kabelbaum hinten für E401MGB (GT)	Rear harness for E401MGB (GT)	1
E402MGB	Hauptkabelbaum '69 (GT 158210-181840), Lichtmaschine mit integrierter Reglerbox	Main harness '69 (GT 158210-181840), AC alternator with integral control box	1
E412MGBGT	Kabelbaum hinten für E402MGB (GT)	Rear harness for E402MGB (GT)	1
E403MGB	Hauptkabelbaum '70 (GT 181841-21900), "Hupenbetätigung am Blinkerhebel"	Main harness '70 (GT 181841-21900), "horn control on indicator stalk"	1
E413MGBGT	Kabelbaum hinten für E403MGB (GT)	Rear harness for E403MGB (GT)	1
E404MGB	Hauptkabelbaum '71 (GT 219000-258000), "Hupenbetätigung in Lenkradmitte"	Main harness '71 (219000-258000), "horn control in centre of steering wheel"	1
E414MGBGT	Kabelbaum hinten für E404MGB (GT)	Rear harness for E404MGB (GT)	1
E405MGB	Hauptkabelbaum '72 (GT 258001-268280), "mit Radiovorbereitung"	Main harness '72 (258001-268280), "introduction of radio"	1
E414MGBGT	Kabelbaum hinten für E405MGB (GT)	Rear harness for E405MGB (GT)	1
E406MGB	Hauptkabelbaum '73 (GT 268281-280480), "RVC Tacho"	Main harness '73 (GT 268281-280480), "RVC Tachometer"	1
E415MGBGT	Kabelbaum hinten für E406MGB (GT)	Rear harness for E406MGB (GT)	1
E406BMGB	zusätzlicher Kabelbaum für E406MGB (GT)	Additional harness for E406MGB	1
E407MGB	Hauptkabelbaum '74 (GT 280480-361000), mit Warnblinker	Main harness '74 (GT 280480-361000) hazard warning lights	1
E416MGBGT	Kabelbaum hinten für E407MGB (GT)	Rear harness for E407MGB (GT)	1
E407BMGB	zusätzlicher Kabelbaum Armaturentafel für E407MGB	Additional harness instrument panel	1
E408MGB	Hauptkabelbaum '74 (GT ab 361001 -), Gummistoßstangenmodelle	Main harness '74 (GT from 361001 -), Rubber bumper models	1
E417MGBGT	Kabelbaum hinten für E408MGB (GT)	Rear harness for E408MGB (GT)	1
E407BMGB	zusätzlicher Kabelbaum Armaturentafel für E408MGB	Additional harness instrument panel for E408MGB	1

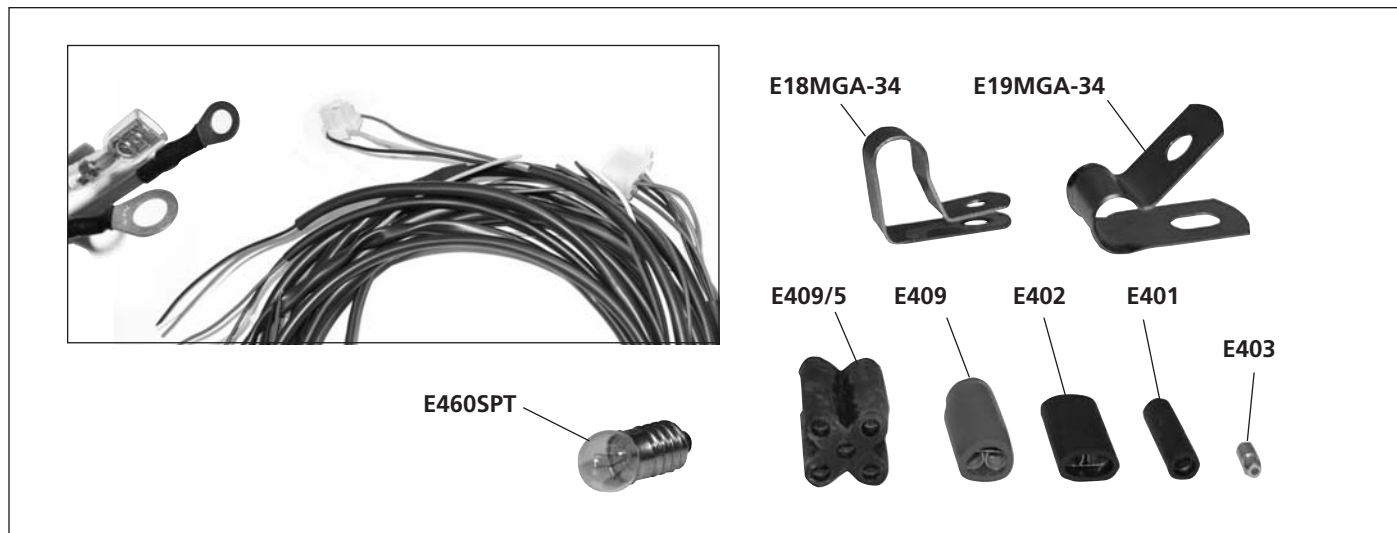

E401	1-Fach Kabelverbinder	Cable connector 1-way	A/R
E402	2-Fach Kabelverbinder	Cable connector 2-way	A/R
E409	3-Fach Kabelverbinder	Cable connector 3-way	A/R
E403	Kabelstecker	Wiring connector bullet	A/R
E18MGA-34	Klammer Kabelbaum	Clip wiring loom	A/R
E19MGA-34	Klammer Kabelbaum + Batteriekabel	Clip wiring loom + battery leads	A/R
E460SPT	Schraubbirne	Bulb	A/R

No.	Bezeichnung	Description	Anzahl/Qty.
E10MGB-25	Chrom-Scheinwerferring außen	Headlamp rim	2
E17MGB-25	Blinker ab 75	Flasher lamp from 75	2
E18MGB-25	Blinkerglas ab 75	Flasher lens from 75	2
E18AMGB-25	Dichtung für Blinker	Gasket flasher	2
E19MGB-25	Rückleuchte bis 69	Stop/tail lamp up to 69	2
E20MGB-25	Chrom-Rand Rückleuchte	Chrome rim rear lamp	2
E21MGB-25	Blinkerglas gelb	Flasher lens amber	2
E22MGB-25	Glas Brems/Rückleuchte	Lens stop/tail lamp	2
E23MGB-25	Dichtung zu Rückleuchtengläser	Gasket lamp lens	2
E23BMGB-25	Dichtung Rückleuchte/Karosserie	Gasket rear lamp/body	2
E24MGB-25	Rückleuchte bis GHN5.....	Stop/tail lamp up to GHN5.....	2
E24AMGB-25	Rückleuchte US spät (Rotes Blinkerglas)	Stop/tail lamp late US (Red flasher lens)	2
E25MGB-25	Glas Rückleuchte bis GHN5...	Lens rear lamp up to GHN5....	2
E25AMGB-25	Glas Rückleuchte Blinker rot	Lens rear lamp flasher red	2
E26MGB-25	Dichtung Rückleuchtenglas	Gasket rear lamp lens	2
E26AMGB-25	Dichtung Rückleuchte/Karosserie	Gasket rear lamp/body	2
E27MGB-25	Rückfahrleuchte	Reverse lamp	2
E28MGB-25	Glas Rückfahrleuchte	Lens reverse lamp	2
E29MGB-25	Dichtung Rückfahrleuchte	Gasket reverse lamp lens	2
E33MGA-30	Dichtung Scheinwerfertopf/Karosserie	Headlamp rubber	2
E37MGA-30	Staubschutzgummi	Headlamp dust excluder	2
E42MGA-30	Schraube Lampenring	Headlamp rim screw	8
E200TR	Paar Scheinwerfereinsätze H4 mit integr. Standlicht, LHD inkl. Birne	Pair H4 headlamp units, with pilot lamp, lhd incl. bulb	1
E200SPT	Paar Scheinwerfereinsätze H4 ohne Standlicht, LHD inkl. Birne	Pair H4 headlamp units, without pilot lamp, lhd incl. bulb	1
E200a	Paar Steinschlagschutzgitter	Pair headlamp stoneguard	1
E201TR6	Lampenstecker mit Kabel	Adapter bulb „Europe“ with lead	2
E202SPT	Lampentopf Kunststoff	Headlamp body polyester	2
E202aSPT	Lampentopf komplett, Metall (ohne Dichtung Scheinwerfertopf/Karosserie)	Headlamp body kit, steel (w/o headlamp rubber)	2
E203SPT	Set Scheinwerfer-Einstellschrauben, Federn + Schrauben	Headlamp screw trimmer set	2
E203MGB	Paar Scheinwerferabdeckungen Plexiglas	Headlamps cowls, 1 pair	1
E250SPT	Blinker/Standlicht vorne	Flasher/side lamp amber/white front	2
E251SPT	Chrom-Rahmen Blinker vorne	Chrome rim flasher lamp front	2
E252SPT	Standlichtglas vorne	Lens side lamp front	2
E253SPT	Blinkerglas vorne	Flasher lens front	2
E254SPT	Blinker/Standlicht-Fassung vorne	Flasher/side lamp backplate front	2
E255SPT	Blinkerdichtung	Gasket flasher	2
E260SPT	Nummernschild-Lampe	Number plate lamp	2
E700	H4-Glühbirne für E200SPT	Bulb, H4 to no. E200SPT	A/R
E710	Glühbirne 12V.21W	Bulb 12V.21W	A/R
E711	Glühbirne 12V.21/5W	Bulb 12V.21/5W	A/R
E713	Glühbirne 12V.5W	Bulb 12V.5W	A/R
E750	Glühbirne 12V.5W (Bajonett)	Bulb 12V.5W (Bayonet)	A/R
E761	Glühbirne 12V.5W	Bulb 12V.5W	A/R

Zeitgenössisches Zubehör: Fern- und Nebelscheinwerfer

Period Style: Driving and Fog Lamps

No.	Bezeichnung	Description	Anzahl/Qty.
E205	Zusatz Fernscheinwerfer (Befestigung unten)	High beam headlamp (stemmount)	2
E205a	Zusatz Fernscheinwerfer (Befestigung hinten)	High beam headlamp (backmount)	2
E206	Zusatz Nebelscheinwerfer n(Befestigung unten)	Fog lamp (stemmount)	2
E206a	Zusatz Nebelscheinwerfer (Befestigung hinten)	Fog lamp (backmount)	2
E720	Glühbirne für Fernscheinwerfer	Bulb for high beam headlamp	2
E721	Glühbirne für Nebelscheinwerfer (12V-48W)	Bulb for fog lamp (12V-48W)	2

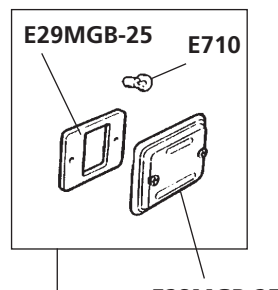
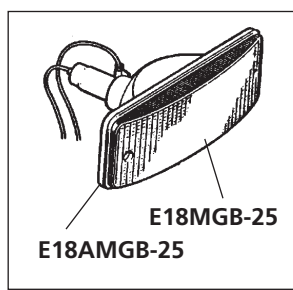
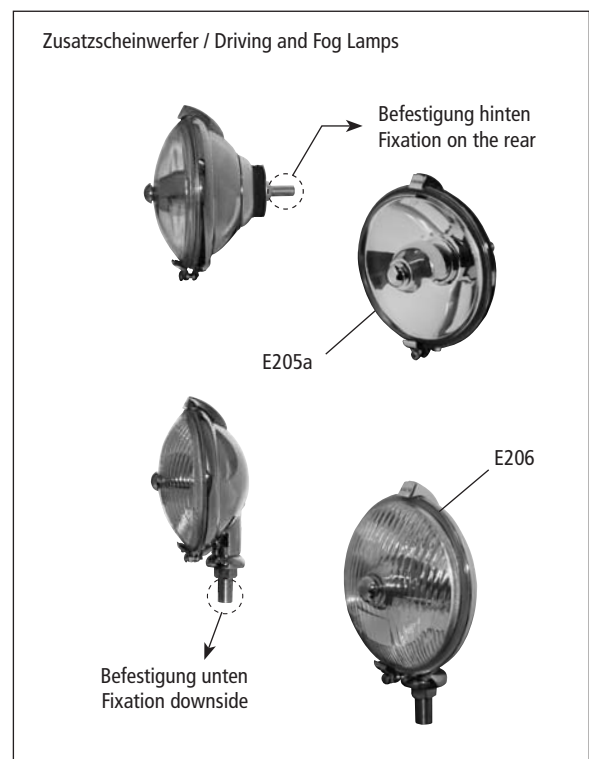
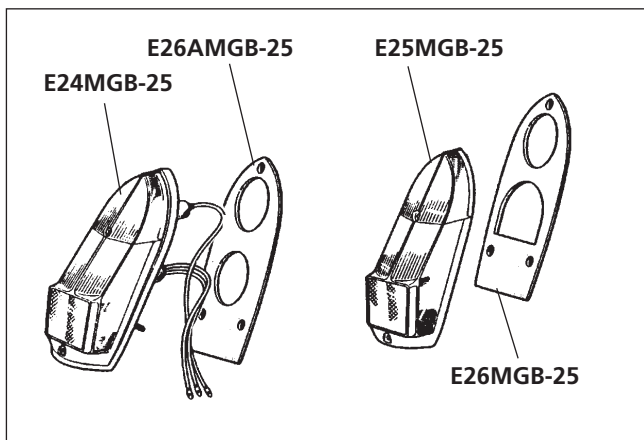
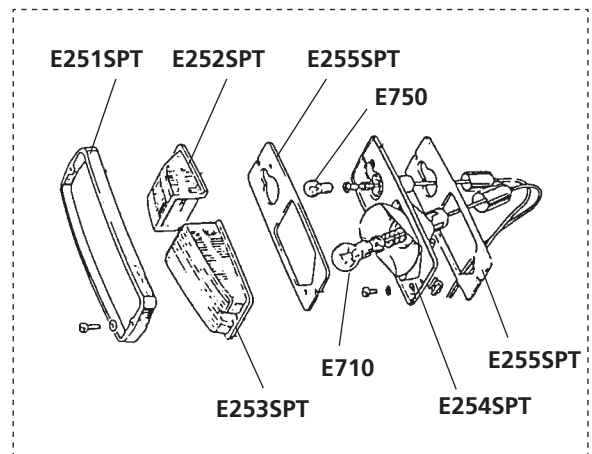
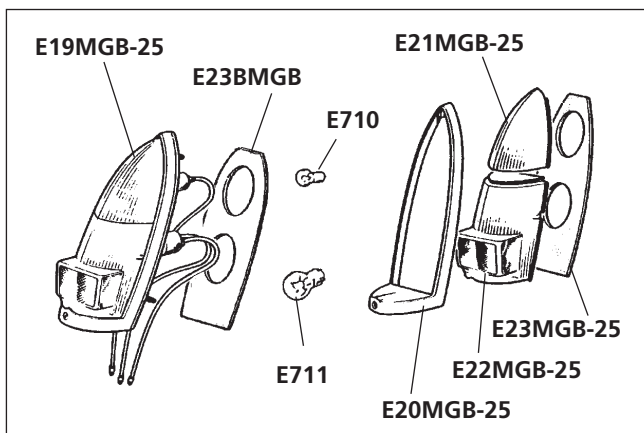
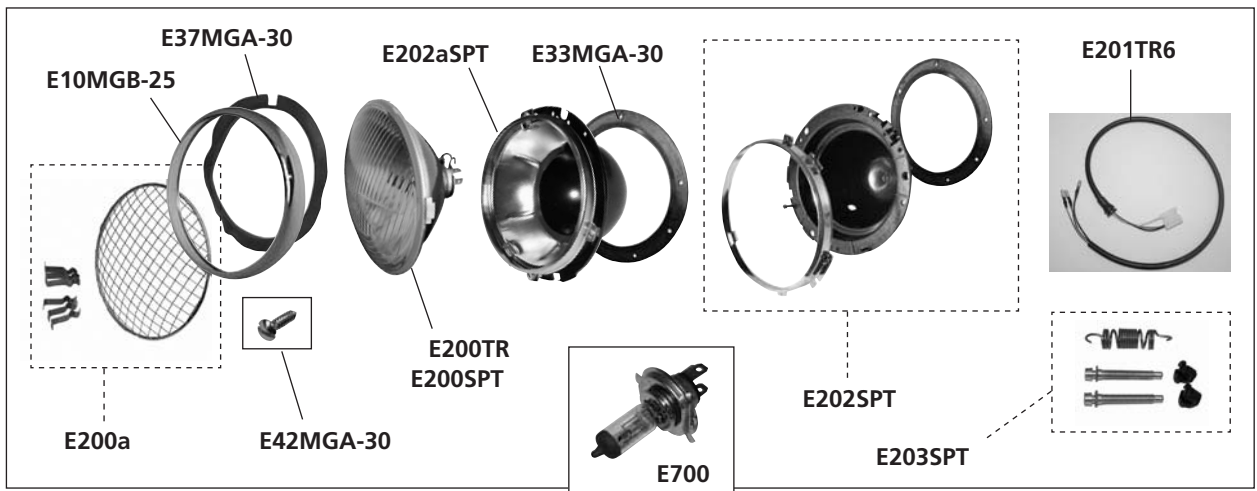

E17MGB-25

E27MGB-25

E250SPT

No.	Bezeichnung	Description	Anzahl/Qty.
E18MGB-35	Nummernschildlampe 62-73	Number plate lamp 62-73	2
E18MGA-35	Deckel Nummernschild-Lampe	Cover number plate lamp	2
E19MGA-35	Lampenglas	Lens lamp	2
E33MGB-25	Innenlampe GT	Tailgate lamp GT	1
E33AMGB-25	Kofferraum-Lampe Roadster	Boot courtesy lamp Roadster	1
E37MGB-25	Lampe	Rubber gasket number plate lamp	2
E38MGB-25	Nummernschild-Lampe auf Stoßstange 1974	Number plate lamp on bumper 1974	2
E41AMGB-25	Lampen-Zwischenstück links für E18MGB-35	Plinth number plate lamp lh for no E18MGB-35	1
E41MGB-25	Lampen-Zwischenstück rechts für E18MGB-35	Plinth number plate lamp rh for no E18MGB-35	1
E42MGB-25	Unterteil Innenleuchte RHD ab Sep.76	Unterteil innenleuchte RHD, from 09/1976	1
E43MGB-25	Lampenglas Innenleuchte	Lens courtesy light	1
E45MGB-25	Innenbeleuchtung ab 76	Interior lamp from 76	1
E46MGB-25	Seitenlampe hinten rechts	Side marker lamp rear rh	1
E47MGB-25	Seitenlampe hinten links	Side marker lamp rear lh	1
E48MGB-25	Seitenlampe vorne rechts	Side marker lamp front rh	1
E49MGB-25	Seitenlampe vorne links	Side marker lamp front lh	1
E50MGB-25	Blinkerglas seitlich vorne rechts	Flasher repeater lens front rh	1
E51MGB-25	Blinkerglas seitlich vorne links	Flasher repeater lens front lh	1
E52MGB-25	Blinkerglas seitlich hinten rechts	Flasher repeater lens rear rh	1
E53MGB-25	Blinkerglas seitlich hinten links	Flasher repeater lens rear lh	1
E53AMGB-25	Dichtung Glas zum Gehäuse	Gasket lens to housing	2
E53BMGB-25	Dichtung Gehäuse zur Karosserie	Gasket housing to body	2
E54MGB-25	Nebellampe hinten	Fog lamp rear	2
E218TR6	Innenlampe auf Konsole	Transmission tunnel lamp	1
E260SPT	Nummernschild-Lampe chrom für Gummistoßstange ab 75	Number plate lamp chrome for rubber bumper from 75	2
E261SPT	Dichtung unter Nummernschildleuchte	Seal, rubber	1

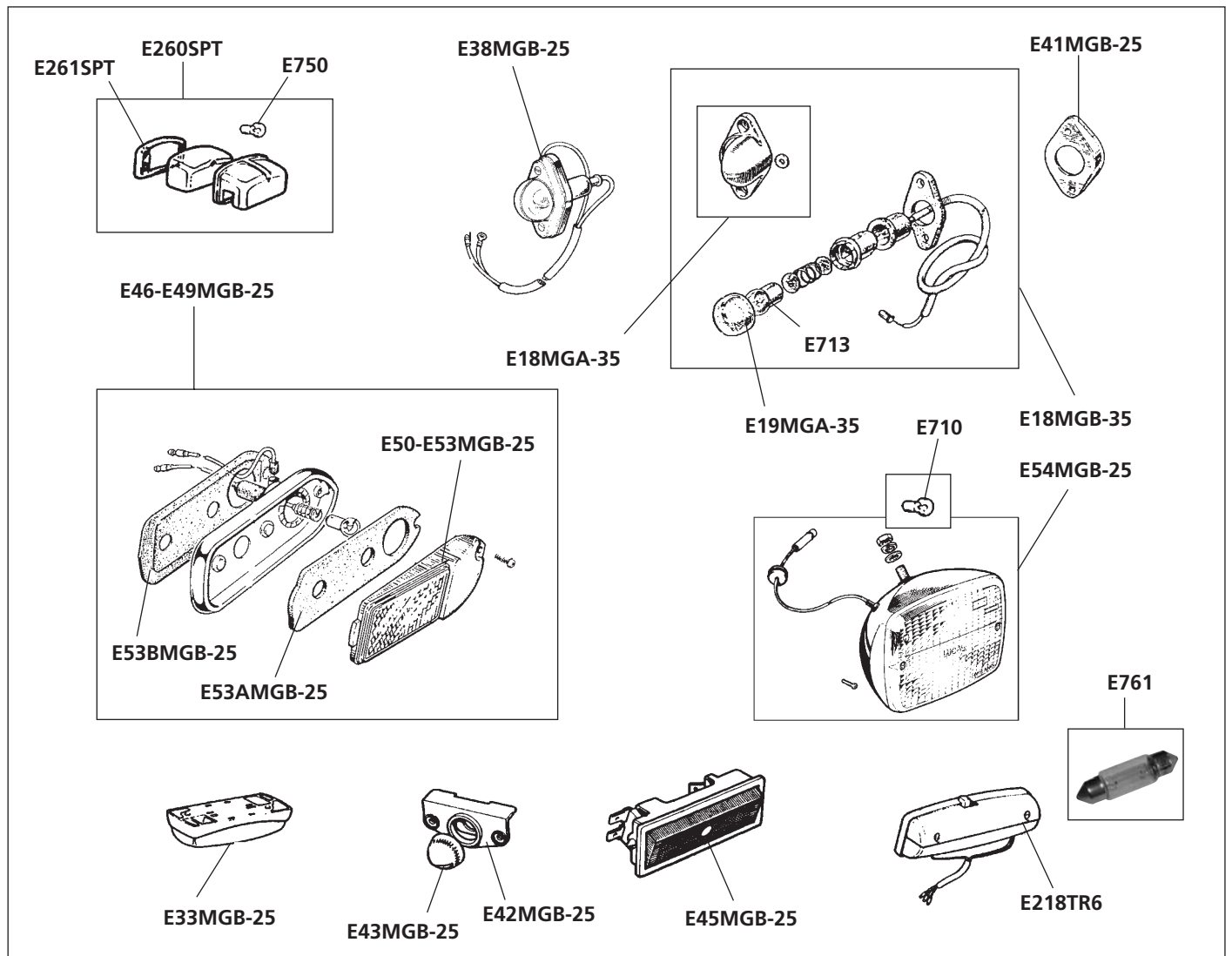

Gummistopfen / Rubber plugs

No.	Bohrungs-Ø in Karosserie / Diam. in body	No.	Bohrungs-Ø in Karosserie / Diam. in body
RS6	6 mm	RS20	20 mm
RS8	8 mm	RS22	22 mm
RS12	12 mm	RS25	25 mm
RS14	14 mm	RS28	28 mm
RS18	18 mm	RS30	30 mm



Kabeltüllen / Cable spouts

No.	Bohrungs-Ø in Karosserie / Diam. in body	No.	Bohrungs-Ø in Karosserie / Diam. in body	No.	Bohrungs-Ø in Karosserie / Diam. in body
RT6	6 mm	RT20	20 mm	RT1 "	25,4 mm (1")
RT9	9 mm	RT21	21 mm	Tülle für Tachowelle, Drehzahlmesserwelle / Cable spout for speedo cable, rev. counter cable	
RT10	10 mm	RT24	24 mm		
RT11	11 mm	RT30	30 mm		
RT14	14 mm	RT34	34 mm		
RT17	17 mm	RT38	38 mm		

RT1MGB Gummiabdeckung Bremszylinderaufnahme MGB
an Spritzwand

Rubber cover brake cylinder MGB

RT1MGB

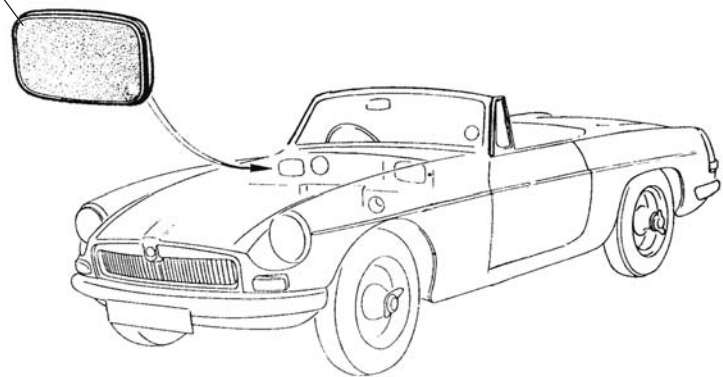

No.	Bezeichnung	Description	Anzahl/Qty.
E05MGA-33	Befestigungssatz Wischermotor für E540SPT	Mounting kit wiper motor to no. E540SPT	1
E07MGA-33	Wischerantriebswelle	Wiper crosshead +rack	1
E505MGB	Wischerarm 5 mm Edelstahl Roadster	Wiper arm 5 mm stainless steel Roadster	2
E505MGB/GT	Wischerarm 5 mm Edelstahl GT	Wiper arm 5 mm stainl. GT	2
E506MGB	Wischerarm 7 mm Edelstahl Roadster	Wiper arm 7 mm stainl. Roadster	2
E506MGB/GT	Wischerarm 7 mm Edelstahl GT	Wiper arm 7 mm stainl. GT	2
E500MGB	Wischerblatt Edelstahl 5 mm/ 10" Roadster	Wiper blade 5 mm / 10" stainless steel Roadster	2
E500MGB/GT	Wischerblatt Edelstahl 5 mm/ 12" GT	Wiper blade 5 mm / 12" stainless steel GT	2
E501MGB	Wischerblatt Edelstahl 7 mm/ 10" Roadster	Wiper blade 7 mm / 10" stainless steel Roadster	2
E501MGB/GT	Wischerblatt Edelstahl 7 mm/ 12" GT	Wiper blade 7 mm / 12" stainless steel GT	2
E510SPT	Wischerantrieb alle Modelle, ab 67 (4-Synchro)	Wiper wheelbox all models from 67 on (4-synchro)	2
E510MGB/GT	Wischerantrieb GT 3-Synchro	Wiper wheelbox GT 3-synchro	2
E510MGB	Scheibenwischer-Antrieb Roadster (3-Synchro)	Wiper wheelbox Roadster (3-synchro)	2
E511MGB/GT	Anbauteile-Satz Wischerantrieb nur GT (3-Synchro)	Bush kit wheelbox only GT (3-synchro)	2
E511SPT	Anbauteile-Satz Wischerantrieb	Bush kit wheelbox	2
E512SPT	Dichtung Wischerantrieb	Gasket wiper wheelbox	2
E513SPT	Mutter Wischerantrieb	Nut wiper wheelbox	2
E520SPT	Wischwasserflasche rund	Wiper wash bottle round	1
E520MGB	Wischwasser-Sack	Wiper wash sack	1
E520AMGB	Halter Wischwasserflasche	Bracket wiper wash bottle	1
E520BMGB	Deckel Wischwasserbehälter zu E520MGB	Lid frontscreen washer bottle for E520MGB	1
E520CMGB	Ventil Scheibenwaschanlage zu E520MGB	Frontscreen washer foot valve for E520MGB	1
E521TR4	Halter Wasserflasche	Bracket washer bottle	1
E525SPT	Scheibenwaschmotor	Wiper wash motor	1
E526SPT	Scheibenwaschpumpe manuel	Frontscreen washer pump manual	1
E530MGB	Scheibenwaschdüse doppelt	Frontscreen washet jet twin	1
E530AMGB	Scheibenwaschdüse Kunststoff schwarz	Frontscreen washer jet plastic black	2
E530SPT	Scheibenwaschdüse chrom	Wiper/wash jet chrome	2
E531SPT	T-Stück	T-piece	1
E532SPT	Kunststoff-Schlauch 3/16" (pro Meter)	Plastic tubing jets 3/16" (per meter)	A/R
E35MGA-32	Kunststoff-Schlauch 1/4" (pro Meter)	Plastic tubing jets 1/4" (per meter)	A/R
E540SPT	AT-Wischermotor DR3A 1-Stufig	Exch. wiper motor DR3A 1-Speed	1
E542SPT	Wischermotor	Wiper motor	1
E542BSPT	Ritzel zu E542SPT	Drive gear to no. E542SPT	1
E550SPT	Halter Wischermotor Edelstahl	Strap motor mounting	1
E552SPT	Gummi unter Wischermotor	Rubber pad, motor mounting	1

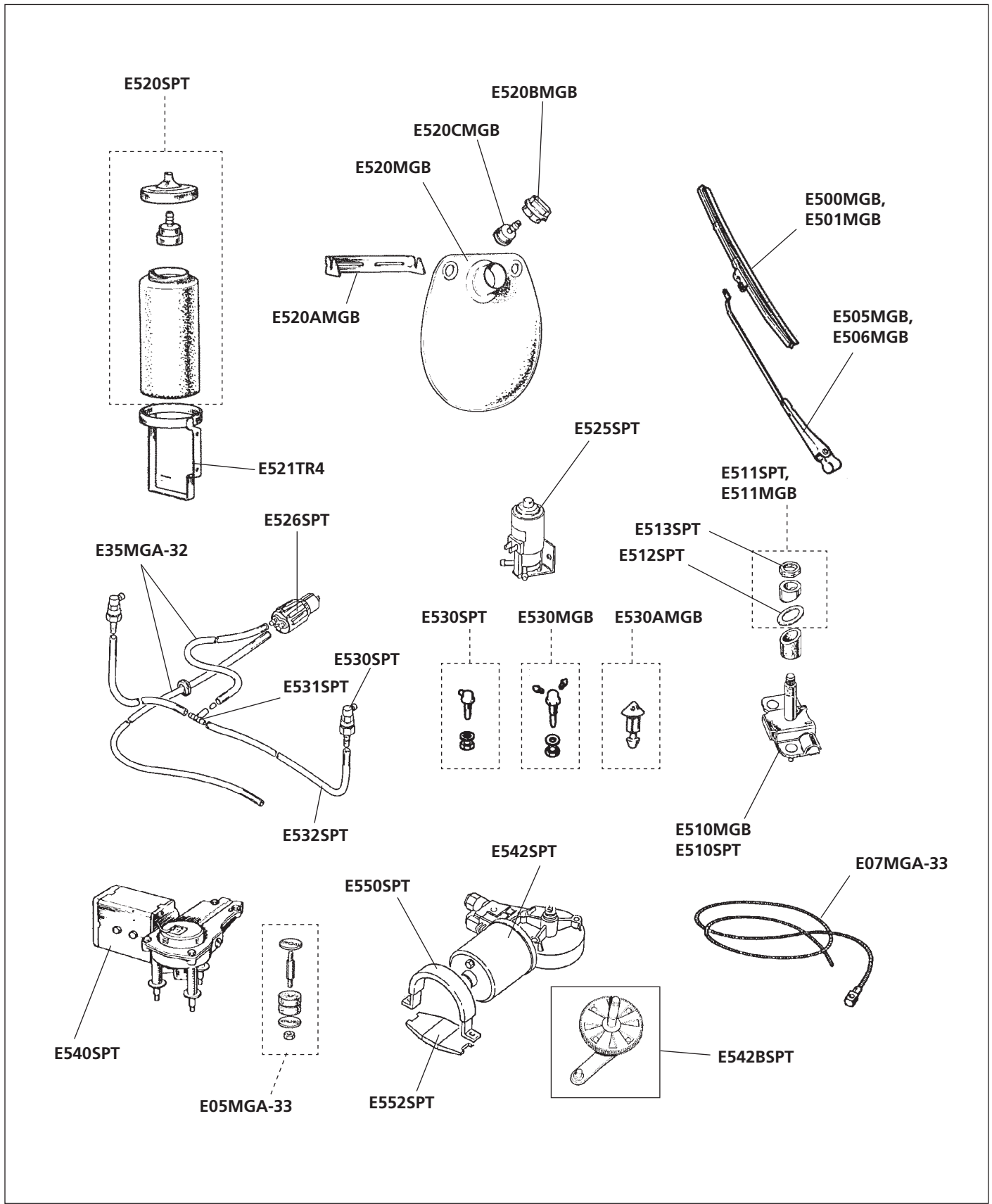

No.	Bezeichnung	Description	Anzahl/Qty.
E07MGB-26	Öldruckschlauch ab Motorblock	Oil pipe from block on	1
E08MGB-26	Verbindungsstück Öldruckschlauch (mechanische Anzeige)	Connector oil pipe to gauge (mechan. system)	1
E55MGB-26	Öldruckgeber US elektrisch	Oil pressure transmitter electric	1
E460SPT	Schraubbirne Armaturenblettbeleuchtung	Bulb instrument panel	A/R
E471SPT	Schlauch Öldruckinstrument	Hose to oil pressure gauge	1
E472SPT	T-Stück Anschluß Öldruckschlauch an Motorblock	T-piece connection oil pipe to block	1
E475ESPT	Öltemperaturinstrument elektrisch, mit Chromrand	Oil temperature gauge, electrical with chrome ring	1
E475MSPT	Öltemperaturinstrument mechanisch, mit Chromrand	Oil temperature gauge, mechanical with chrome ring	1
E475aSPT	Geber für Öltemperaturinstrument E475SPT oder Wassertemperaturinstrument E485SPT	Transmitter oil temperature gauge E475SPT or water temperature E485SPT	A/R
E475bSPT	Adapter zu E475SPT an Ölwanne oder zu E485SPT an Thermostatgehäuse	Adaptor to E475SPT to oil sump or to E485SPT to thermostat housing	1
E476SPT	Amperemeter mit Chromrand	Amperemeter gauge with chrome ring	1
E477SPT	Voltmeter mit Chromrand	Voltmeter gauge with chrome ring	1
E478SPT	Zeituhr mit Chromrand	Clock with chrome ring	1
E480SPT	Doppelinstrument Wassertemperatur u. Öldruck	Double instrument water temperature and oil pressure gauge	1
E480bSPT	Adapter für E480SPT (Wasseranschluß)	Adaptor for E480SPT (Water connection)	1
E481SPT	Öldruckinstrument mechanisch	Oil pressure gauge	1
E482SPT	Tankuhr	Fuel gauge	1
E485SPT	Wassertemperaturinstrument mechanisch	Water temperature gauge, mechanical	1
E490SPT/52	Chromrand für "SMITHS" Instrumente Ø 52 mm	Chrome ring for "SMITHS" instruments Ø 52 mm	A/R
E490SPT/80	Chromrand für "SMITHS" Instrumente Ø 80 mm	Chrome ring for "SMITHS" instruments Ø 80 mm	A/R
E490SPT/100	Chromrand für "SMITHS" Instrumente Ø 100 mm	Chrome ring for "SMITHS" instruments Ø 100 mm	A/R
E450MGB	AT-Tachometer (Überholung des eigenen Tachometers)	Exchange speedometer (Rebuilding your existing speedometer)	1
E460MGB	AT-Drehzahlmesser (Überholung des eigenen Drehzahlmessers)	Exchange speedo drive (Rebuilding your existing tachometer)	1



Wellen LHD

Cables LHD

No.	Bezeichnung	Description	Anzahl/Qty.
W8	Winkeltrieb 3-Synchro zu Tachowelle	Speedo drive 3-synchro to speedo cable	1
W10MGB	Tachowelle Schaltgetriebe 62-67, 3-Synchro	Speedo cable non-overdrive g/box 62-67, for 3-synchro models	1
W11MGB	Tachowelle Overdrive Getriebe 62-67, 3-Synchro	Speedo cable overdrive g/box 62-67, for 3-synchro models	1
W12MGB	Tachowelle Schaltgetriebe 68-76, 4-Synchro	Speedo cable non-overdrive g/box 68-76, for 4-synchro models	1
W13MGB	Tachowelle Overdrive Getriebe 68-76, 4-Synchro	Speedo cable overdrive g/box 68-76, for 4-synchro models	1
W14MGB	Tachowelle Schaltgetriebe 76-80 ab GHN/D5 410001	Speedo cable non-overdrive g/box 76-80 from GHN/D 410001	1
W15MGB	Tachowelle Overdrive Getriebe 76-80 ab GHN/D5 410001	Speedo cable overdrive g/box 76-80 from GHN/D 410001	1
W24MGB	Drehzahlmesserwelle LHD	Speedo drive LHD	1

Wellen RHD

Cables RHD

W8	Winkeltrieb zu Tachowelle	Speedo drive to speedo cable	1
W10MGB	Tachowelle Schalt-Getriebe 62-63	Speedo cable non-overdrive g/box 62-63	1
W16MGB	Tachowelle Schalt-Getriebe März 63-67, 3-Synchro	Speedo cable non-overdrive g/box 3/63-67, for 3-synchro models	1
W17MGB	Tachowelle Overdrive-Getriebe 63-67, 3-Synchro	Speedo cable overdrive g/box 63-67, for 3-synchro models	1
W18MGB	Tachowelle Overdrive-Getriebe 62-63, 3-Synchro + 67-76, 4-Synchro	Speedo cable overdrive g/box 62-63, for 3-synchro models + 67-76, for 4-synchro models	1
W19MGB	Tachowelle Schalt-Getriebe 67-76, 4-Synchro	Speedo cable non-overdrive g/box 67-76, for 4-synchro models	1
W20MGB	Tachowelle Overdrive- und Schalt-Getriebe 76-80 ab GHN/D5 410001	Speedo cable overdrive- and non-overdrive g/box 76-80 from GHN/D 410001	1
W25MGB	Drehzahlmesserwelle RHD	Speedo drive RHD	1

**Hinweis
Note:**

Original-Tachometer und Drehzahlinstrumente sind nicht mehr lieferbar. Diese Instrumente können aufbereitet werden. Lieferzeit ca. 6-8 Wochen. Bitte fragen Sie nach!

Original Speedo/Tachometer instruments are not longer available. Please ask for our service to rebuild the instruments!

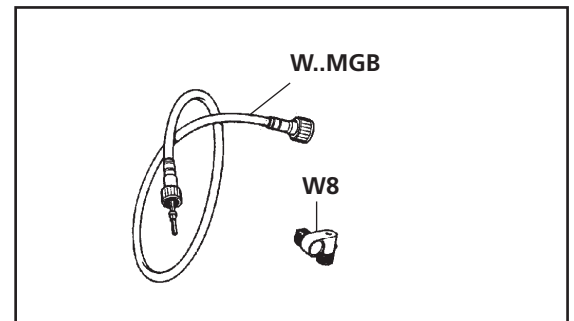

No.	Bezeichnung	Description	Anzahl/Qty.
i01MGB-33	Armaturenbrett LHD 68-72 USA	Facia panel LHD 68-72 US	1
i01AMGB-33	Armaturenbrett-Abdeckung 68-72 USA	Facia panel top crash pad 68-72 US	1
i02MGB-33	Armaturenbrett LHD 72-77	Facia panel LHD 72-77	1
i02AMGB-33	Armaturenbrett-Abdeckung 72-77	Facia panel top crash pad 72-77	1
i03MGB-33	Verkleidung Armaturenbrett LHD 77-80	Repair kit facia panel LHD 77-80	1
i03MGB-TOP	Armaturenbrett Oberteil	Crash pad, dash top	1
S06MGB-33	Handschuhfach-Schloss Blecharmaturenbrett	Glove box lock steel fascia panel	1
S06AMGB-33	Handschuhfach-Schloss Kunststoffarmaturenbrett 72-77	Glove box lock plastic fascia panel 72-77	1
S06BMGB-33	Handschuhfach-Schloss Kunststoffarmaturenbrett ab 77	Glove box lock plastic fascia panel from 77	1
i08MGB-33	Abzeichen MG für Deckel Radioöffnung	Emblem MG on dash cover radio hole	1
i09MGB-33	Deckel Radioöffnung	Cover radio hole blanking	1
i10MGB-33	Chrom-Rand Radioöffnung	Chrome finisher radio blanking	1
i11MGB-33	Klammer	Clip	2
i13MGB-33	Radiokonsole Blecharmaturenbrett 62-67	Radio console steel fascia 62-67	1
i14MGB-33	Radiokonsole Kunststoffarmaturenbrett 68-72 LHD	Radio console plastic fascia 68-72 LHD	1
i14AMGB-33	Radiokonsole Kunststoffarmaturenbrett 72-77	Radio console plastic fascia 72-77	1
i15MGB-33	Radiokonsole Kunststoffarmaturenbrett ab 77	Radio console plastic fascia from 77	1
i17MGB-33	Mittelkonsole ab 72	Centre console from 72	1
i21MGB-33	Aschenbecher (schwarzer Deckel) Modelle mit Mittelkonsole	Ashtray (black top) models with centre console	1
K28MGB-13	Lüftungsschlauch	Demister hose	2
K29MGB-13	Frischlufdüse Armaturenbrett rechts	Facia vent rh	1
K29AMGB-13	Frischlufdüse Armaturenbrett links	Facia vent lh	1
S31MGA-02	Aschenbecher + Chromdeckel	Ashtray +chrome top	1
i41MGB/LHD	Handschuhfach LHD	Glove box LHD	1
i42MGB	Schutzleiste Blech-Armaturenbrett	Crash rail steel fascia	1
i42BMGB	Schutzleiste um Instrumente	Cowl, instrument	1
i45MGB	Armlehne Mittelkonsole Vinyl schwarz 4-Synchro ab 70	Armrest centre console vinyl black 4-synchro from 70	1
i45MGBL	Armlehne Mittelkonsole Leder schwarz 4-Synchro ab 70	Armrest centre console leather black	1
i45BMGB-33	Scharnier Armlehne Konsole	Hinge armrest console	1
i45CMGB-33	Unterteil des Armlehnenverschlusses	Striker catch armrest	1
i45EMGB-33	Oberteil des Armlehnenverschlusses	Striker armrest console	1
i45FMGB-33	Aufnahmeplatte zu i45EMGB-33	Peg locating plate to no i45EMGB-33	1
E54MGA-35	Abdeckung Radioöffnung - Satz (5 Teile)	Blanking plate set (5 pcs) radio hole	1

Weitere Innenausstattungssteile - siehe ab Seite 110

For more interior trim parts - see page 110 following

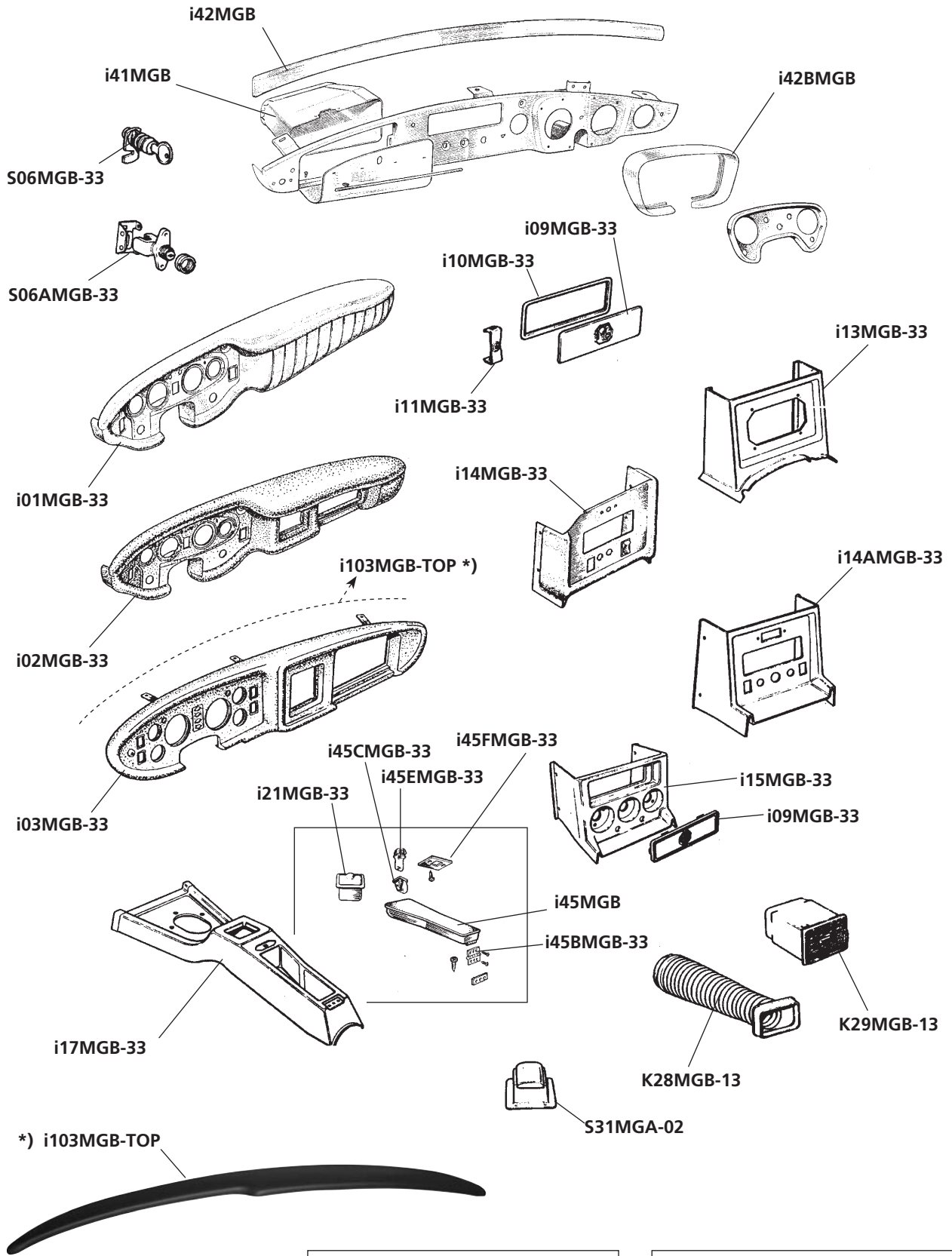

No.	Bezeichnung	Description	Anzahl/Qty.
KA05MGB-28	Rep.-Blech Kotflügel hinten B-Säule zu Radhaus *)	Rep.-panel wing rear B-post to wheel arch *)	1/1
KA06MGB-27	Spritzblech vorne *)	Baffle plate front *)	1/1
KA07MGB-27	Gummi-Spritzblech	Rubber baffle plate	2
KA08MGB-28	Türhaut *)	Door skin l*)	1/1
KA09MGB-27	Rep.-Blech Kotflügel vorne *)	Rep.-panel wing front *)	1/1
KA10MGB-27	B-Säule *)	B-post *)	1/1
KA10MGB-28	Verlängerung Spritzblech *)	Extension baffle plate *)	1/1
KA36MGB-27	Frontschürze ohne Lufteinlass	Front valance no air holes	1
KA36BMGB-27	Frontschürze mit 2 Lufteinlässen	Front valance 2 air holes	1
KA36DMGB-27	Frontschürze ab 75	Front valance rubber bumper from 75	1
KA36MGB-5B	Frontschürze "Sebring Style"	Front valance " Sebring style"	1
KA41AMGB-27	Unterlegscheibe lang Kotflügel vorne	Washer plate long front wing	2

Roadster

KA01MGB-27	Original-Karosserie Roadster (Chromstoßstange) 67-75 **)	Original bodyshell Roadster (chrome bumper) 67-75 **)	1
KA01AMGB-27	Original-Karosserie Roadster (Gummistoßstange) ab 75 **)	Original bodyshell Roadster (chrome bumper) from 75 **)	1
KA01BMGB-27	Motorhaube Roadster Aluminium bis G-HN4-187169 (62-69)	Bonnet Roadster Aluminium up to G-HN4-187169 (62-69)	1
KA01CMGB-27	Motorhaube Roadster von G-HN5-187170 (69-80)	Bonnet Roadster from G-HN5-187170 (69-80)	1
KA03MGB-27	Kotflügel Roadster GHN3 vorne bis 68 *)	Wing Roadster GHN3 front up to 68 *)	1/1
KA03BMGB-27	Kotflügel Roadster GHN4 +5 ab 68 -75 vorne *)	Wing Roadster GHN4+5 from 68-75 front *)	1/1
KA03FMGB-27	Kotflügel Roadster (Gummistoßstange) ab 75 vorne *)	Wing Roadster from 75 front (rubber bumper model) *)	1/1
KA08MGB-27R	Kotflügel Roadster bis 75 hinten rechts	Wing Roadster up to 75 rear , rh	1/1
KA08MGB-27L	Kotflügel Roadster bis 75 hinten links	Wing Roadster up to 75 rear , lh	1/1
KA08CMGB-27	Kotflügel Roadster ab 75 hinten *)	Wing Roadster from 75 rear *)	1/1
KA11AMGB-27	Heckschürze Roadster (Gummistoßstange)	Lower panel rear Roadster (rubber bumper model)	1
KA11MGB-27	Heckschürze Roadster bis 75 (Chromstoßstange)	Lower panel rear Roadster up to 75 (chrome bumper)	1
KA11CMGB-27	Rep.-Blech Heckschürze bis 75 unten	Rep.-panel rear valance up to 75 lower	1
KA11DMGB-27	Rep.-Blech Heckschürze ab 75 unten	Rep.-panel rear valance from 75 lower	1
KA19MGB-27	Türe Roadster spät *)	Door Roadster late *)	1/1
KA31MGB-29	Kofferraumdeckel Roadster	Boot lid Roadster	1
KA32MGB-28	Deckblech Kofferraum	Rear deck	1

Roadster**GT**

KA02MGB-27	Original-Karosserie GT (Chromstoßstange) bis 67-75 **)	Original bodyshell GT 67-75 **)	1
KA02AMGB-27	Original-Karosserie GT (Gummistoßstange) ab 75 **)	Original bodyshell GT from 75 **)	1
KA04MGB-27	Kotflügel GT vorne früh (Chromstoßstange) 64-68 *)	Wing GT front early model (chrome bumper) 64-68 *)	1/1
KA04CMGB-27	Kotflügel GT vorne (Chromstoßstange) 68-75 *)	Wing GT front (chrome bumper) 68-75 *)	1/1
KA04DMGB-27	Kotflügel GT hinten ab 75 (Gummistoßstange) *)	Wing GT front from 75 (rubber bumper) *)	1/1
KA09MGB-GT	Kotflügel GT vorne ab 75 *)	Wing GT front from 75 *)	1/1
KA09BMGB-GT	Kotflügel GT hinten bis 75 *)	Wing GT rear up to 75 *)	1/1
KA11BMGB-27	Heckblech GT (Gummistoßstange) bis 75	Lower panel rear GT (rubber bumper model) up to 75	1
KA11EMGB	Heckblech GT (Chromstoßstange)	Lower panel rear GT (chrome bumper model)	1
KA20MGB-27	Türe GT rechts	Door GT rh	1
KA20AMGB-27	Türe GT links	Door GT lh	1
KA24MGB-29	Heckklappe GT	Boot lid GT	1
KA100MGB	Frontspoiler "Leyland Special Tuning"	Front spoiler "Leyland Special Tuning"	1

GT**MGC**

KA01MGC	Motorhaube MGC	Bonnet MGC	1
KA01MGC-FG	Motorhaube MGC, Kunststoff	Bonnet MGC, plastic	1

MGC

*) Links/rechts. Bitte Fahrzeugseite angeben.

*) Please refer side of the car -lh or rh.

**Hinweis
Note:**

**) Rohkarosserie von "British Motor Heritage"
für Roadster oder GT-Modelle. Bitte fragen Sie nach!

**) Original bodyshell (British Motor Heritage)
for roadster and GT models on demand!

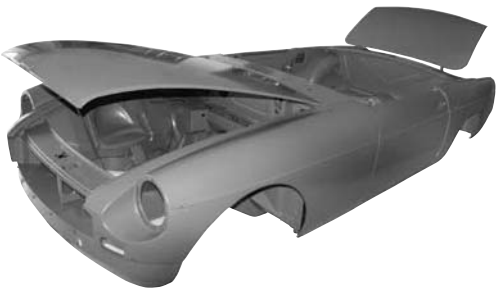
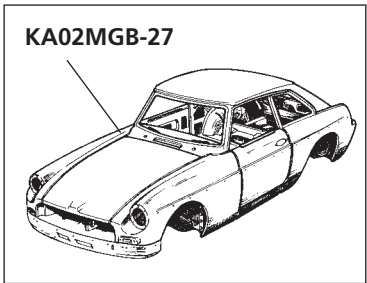
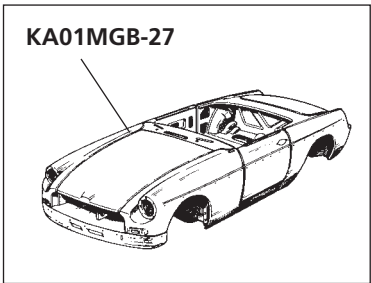

KA01MGC..

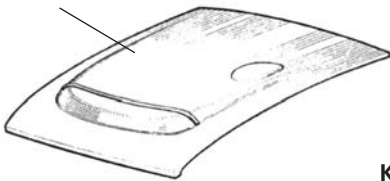

KA32MGB-27

KA08..MGB-27

KA10MGB-27

KA31MGB-29

KA01BMGB
KA01CMGB
KA02BMGB
KA02CMGB



KA11MGB-27,
KA11AMGB-27

KA11C+11DMGB-27

KA10AMGB-28

KA08..MGB-27

KA03..MGB-27
KA04..MGB-27

KA10AMGB-27

KA05MGB-28

KA07MGB-27

KA37MGB-27

KA06MGB-27

KA06MGB-27

KA08MGB-27

KA36MGB-27

KA03..MGB-27
KA04..MGB-27

KA09MGB-27

KA10MGB-28

KA19+20MGB-27



KA36MGB-SB



KA24MGB-29

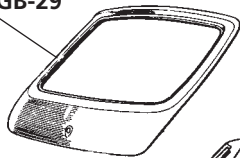

KA10MGB-27

KA10AMGB-27

KA100MGB

KA11BMGB-27,
KA11EMGB-27

KA09..MGB-GT



No.	Bezeichnung	Description	Anzahl/Qty.
KA04MGB-28	Stossdämpfer-Halteplatte hinten *)	Shocker mounting plate rear *)	1/1
KA10MGB-28	Verlängerung Spritzblech *)	Extension baffle plate *)	1/1
KA12MGB-27	Kofferraum-Boden aussen rechts	Boot floor panel outer rh	1
KA12AMGB-27	Kofferraum-Boden aussen links	Boot floor panel outer lh	1
KA13MGB-27	Radkasten innen hinten *)	Wheelarch inner rear *)	1/1
KA13AMGB-27	Radkasten innen hinten GT *)	Wheelarch inner rear GT *)	1/1
KA14MGB-27	Radkasten aussen hinten *)	Wheelarch outer rear *)	1/1
KA15MGB-27	Kofferraum-Bodenblech bis 75 (Chromstoßstange)	Boot floor up to 75 (Chrome bumper)	1
KA15AMGB-27	Kofferraum-Bodenblech ab 75 (Gummistoßstange)	Boot floor from 75 (Rubber bumper)	1
KA16MGB-27	Batterie-Abdeckung 6V	Battery cover 6V	1
KA16AMGB-27	Batterie-Abdeckung 12V	Battery cover 12V	1
KA17MGB-27	Gummi-Dichtung Batteriedeckel	Rubber seal battery cover	1
KA18MGB-27	Klemmschraube zu Batteriedeckel KA16	Fastener to battery panel KA16	2
KA29MGB-27	Motorhaube-Verschlussblech bis 75	Bonnet lock panel up to 75	1
KA29AMGB-27	Motorhaube-Verschlussblech ab 75	Bonnet lock panel from 75	1
KA30MGB-27	Verstärkungsblech Radkasten*)	Reinforcement panel wheelarch *)	1/1
KA31MGB-27	Kühler-Blech-Verstärkung bis 75 (Chromstoßstange)	Platform reinforcement radiator up to 75 (Chrome bumper)	1
KA32MGB-27	Kühler-Blech-Verstärkung ab 75 (Gummistoßstange)	Platform reinforcement radiator from 75 (Rubber bumper)	1
KA33MGB-27	Kühler-Luftleitblech bis 75 (Chromstoßstange)	Radiator panel up to 75 (Chrome bumper model)	1
KA34MGB-27	Kühler-Luftleitblech ab 75 (Gummistoßstange)	Radiator panel from 75 (Rubber bumper model)	1
KA35MGB-27	Träger Kühler-Luftleitblech bis 75 (Chromstoßstange)	Radiator panel support up to 75 (Chrome bumper model)	1
KA35AMGB-27	Träger Kühler-Luftleitblech ab 75 (Gummistoßstange)	Radiator panel support from 75 (Rubber bumper model)	1
KA37MGB-27	Aussenschweller *)	Outer sill panel *)	1/1
KA38MGB-27	Innenschweller *)	Inner sill *)	1/1
KA39MGB-27	Schwellerende hinten *)	Filler panel rear sill *)	1/1
KA40MGB-27	Profilblech Schweller *)	Castle section *)	1/1
KA41MGB-27	Innerer Längsträger *)	Inner sidemember panel *)	1/1
KA42MGB-27	Mittlerer Querträger	Centre crossmember	1
KA43MGB-27	Bodenblech 4-Synchro Modelle *)	Floor panel 4-synchro models *)	1/1
KA43DMGB-27	Bodenblech 3-Synchro Modelle *)	Floor panel 3-synchro models *)	1/1
KA44MGB-27	Wagenheber-Ansatzstück	Jacking point	2
KA45MGB-27	Verstärkung Wagenheberaufnahme	Reinforcement panel jacking point	2
KA46MGB-27	Längsträger vorne ab 75 *)	Sidemember assy front from 75 *)	1/1
KA48MGB-27	Längsträger vorne bis 75 *)	Sidemember assy front up to 75 *)	1/1
KA50MGB-27	Innenkotflügel vorne bis 75 *)	Wheelarch inner panel front up to 75 *)	1/1
KA54MGB-27	Innenkotflügel vorne ab 75 *)	Wheelarch panel front from 75 *)	1/1
KA60MGB-28	Längsträger hinten ab 75 *)	Sidemember assy rear from 75 *)	1/1
KA61MGB-28	Längsträger hinten bis 75 *)	Sidemember assy rear up to 75 *)	1/1
KA62MGB-28	Verschlussblech Längsträger hinten ab 75 *)	Plate closing sidemember rear up to 75 *)	1/1
KA63MGB-28	Verschlussblech Längsträger hinten bis 75 *)	Plate closing sidemember rear from 75 *)	1/1
KA65MGB	Blech unter Armaturenbrett seitlich *)	Extension baffle plate *)	1/1
KA66MGB	Stirnwand oben	Upper bulkhead	1

*) Links/rechts. Bitte Fahrzeugseite angeben.

*) Please refer side of the car -lh or rh

Weitere Blechteile auf Anfrage!

More body panels on demand!

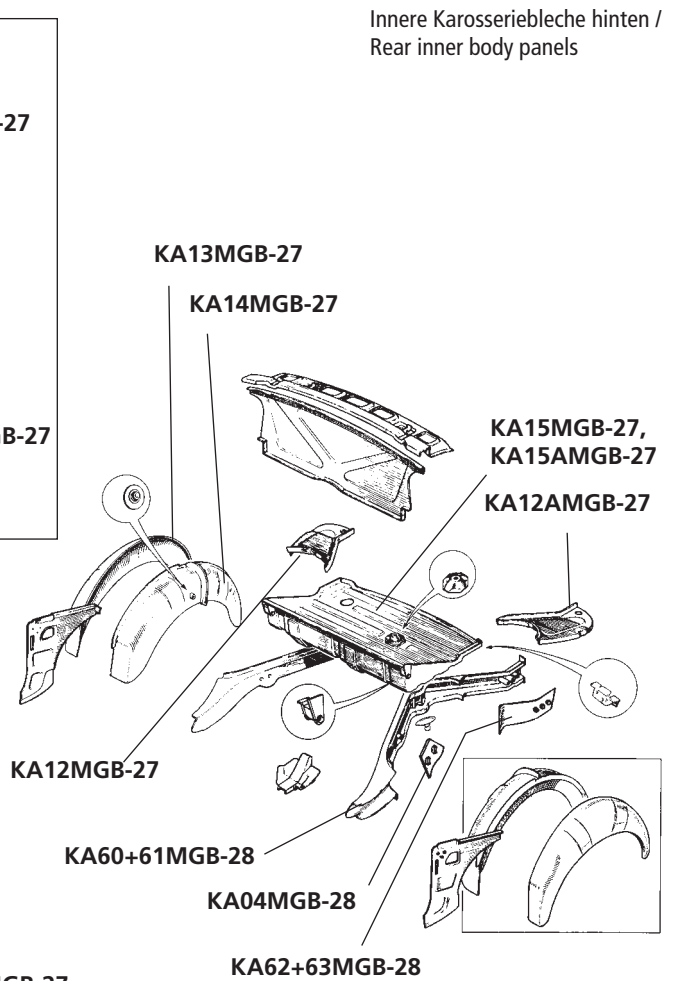
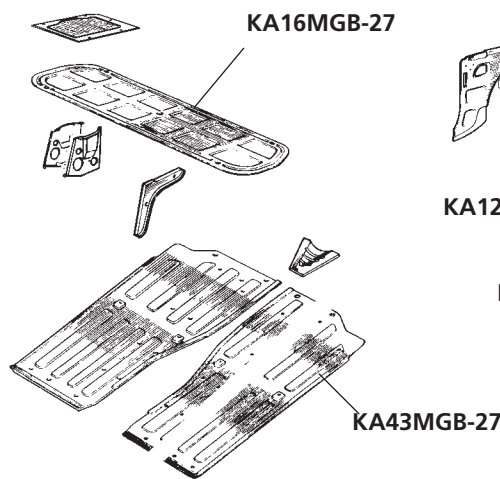
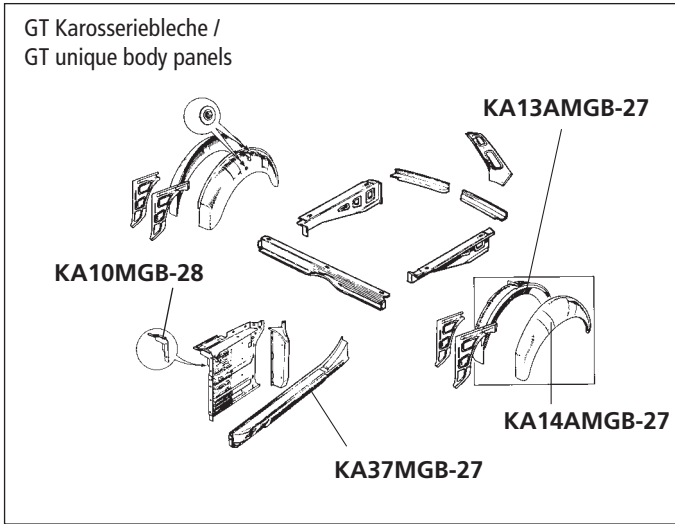
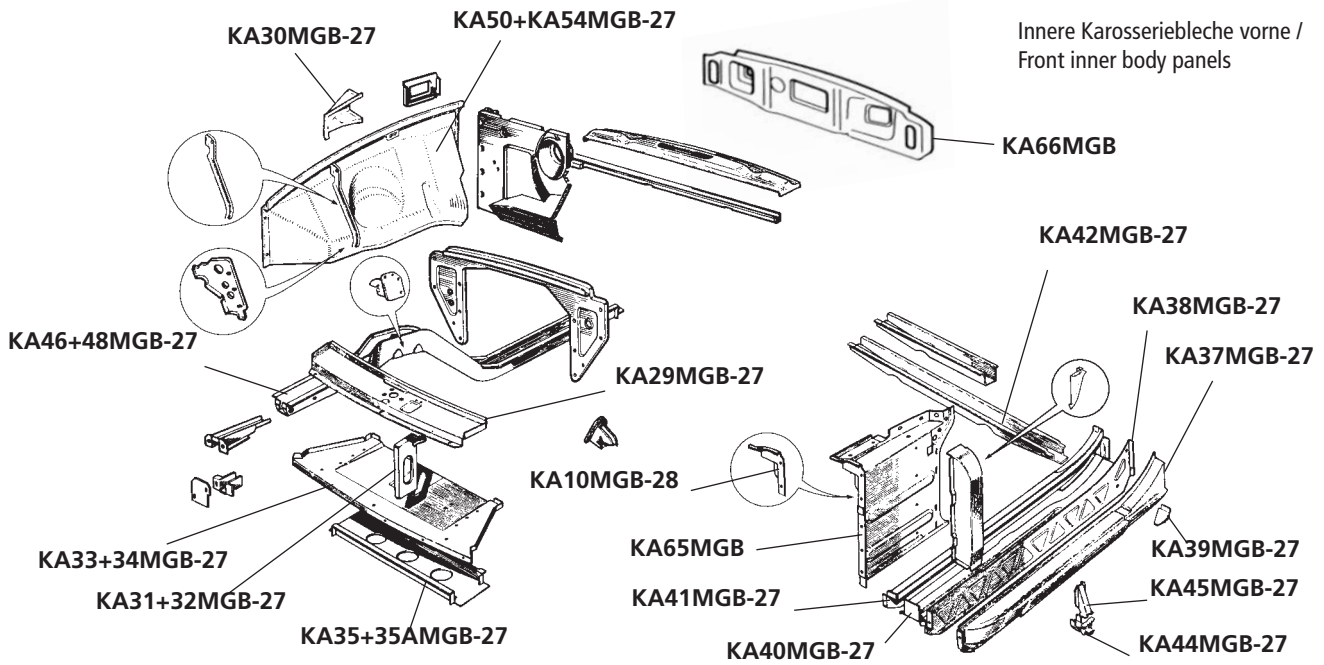

Verdecke (Pack-away Type) 63-70

Hoods (Pack-away type) 63-70

No.	Bezeichnung	Description	Anzahl/Qty.
i1MGB/F	Verdeck Vinyl schwarz, mit Reißverschluß-Heckfenster	Hood Vinyl black, with zip out window	1
i2MGB/F	Verdeck Canvas schwarz, mit Reißverschluß-Heckfenster	Hood Canvas black, with zip out window	1
i3MGB/F	Verdeck Mohair schwarz, mit Reißverschluß-Heckfenster	Hood Mohair black, with zip out window	1

Verdecke (Klappgestänge) 70-80

Hoods (Folding frame) 70-80

i1MGB	Verdeck Vinyl schwarz, mit Reißverschluß-Heckfenster	Hood Vinyl black, with zip out window	1
i2MGB	Verdeck Canvas schwarz, mit Reißverschluß-Heckfenster	Hood Canvas black, with zip out window	1
i3MGB	Verdeck Mohair schwarz, mit Reißverschluß-Heckfenster	Hood Mohair black, with zip out window	1

SR7	Senkkopf-Schraube UNF 1/4 x 1/2"	Countersunk screw UNF 1/4 x 1/2"	6
SR7-1 3/4"	Senkkopf-Schraube UNF 1/4 x 1 3/4"	Countersunk screw UNF 1/4 x 1 3/4"	6
SR8	Senkkopf-Schraube UNF 1/4 x 3/4"	Countersunk screw UNF 1/4 x 3/4"	4
i26MGA-39	Verdeck-Haken chrom hinten tränenförmig	Rear hood bar locator teardrop chrome	2
i27MGA-39	Unterlegdeckel Dachbefestigung hinten	Washer cup plate retaining	2
i41MGB-41	Verdeck-Leiste vorne	Header rail	1
i41AMGB-41	Klötzchen unter Dachleiste	Pad header rail	2
i42MGB-41	Halter Dachleisten-Dichtung	Retainer roof seal tourer	1
i43MGB-41	Gummi-Dichtung Dachleiste/Scheibe	Rubber seal header rail	1
i45MGB-41	Verdeck-Gestell "Pack-away" links und rechts	Early hood frame "Pack-away" lh + rh	1
i46MGB-41	Verdeck-Gestell spät grau	Hood frame late type grey	1
i47MGB-41	Verdeck-Gestell spät schwarz	Hood frame late type black	1
i50MGB-41	Verdeck-Klammer chrome	Hood catch chrome finish	2
i51MGB-41	Verdeck-Klammer satin	Hood catch stain finish	2
i52MGB	Verdeckhalter an Frontscheibenrahmen	Bracket, hood fastening	2
i53MGB-41	Verdeck-Befestigungs-Lasche	Hood fastener tongue	2
i54MGB-41	Platte Verdeckbefestigung	Hood fastener backplate	2
i56MGB-41	Verdeck-Führungssockel Steckgestell	Hood locating socket	2
i57MGB-41	Verdeck-Befestigungs-Platte	Locating socket hood fastener	2
i58MGB-41	Tasche Haltebügel Spritzdecke	Stowage bag tonneau rail	1
i59MGB-41	Verdecktasche (Pack-away Verdeck)	Bag hood stowage (Pack-away hodd)	1
i60MGB-41	Tasche Verdeckgestänge (Pack-away Verdeck)	Stowage bag hood frame (Pack-away hood)	1
i61MGB-41	Verdeck-Halteriemen	Hood stowage strap	2
i103	Druckknopfteil auf Karosserie	Stud tonneau	A/R
i105	Popniete zur Befestigung von i103	Rivet to stud no. i103	A/R
i113	Verdeckstift	Peg tonneau fixing	8
i114	Halter Spritzdecke	Peg fastener	4
i117	Kontermutter	Nut	8

- Fortsetzung nächste Seite

- to be continued on next page!

Farbige Verdecke und Abdeckungen auf Anfrage!

More colours for hoods and tonneaus on demand!

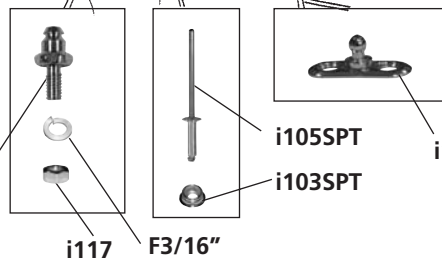
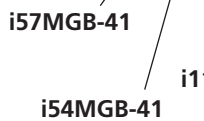
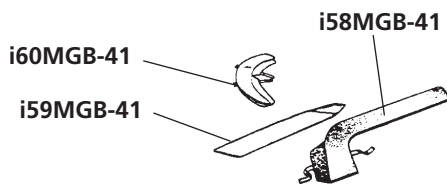
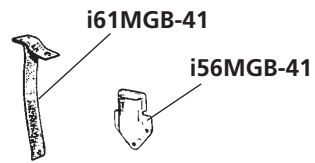
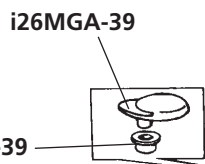
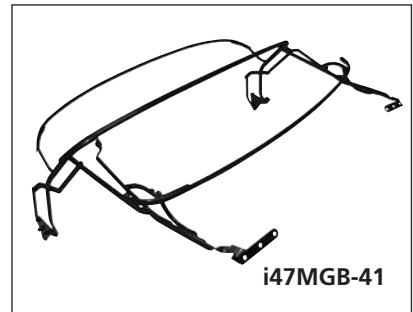
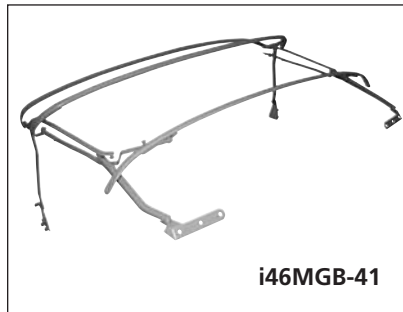
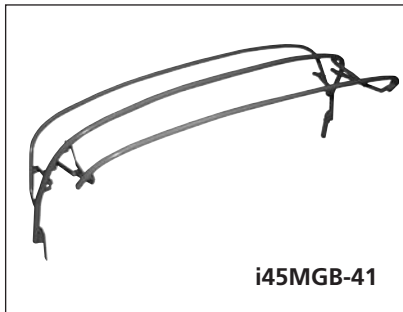
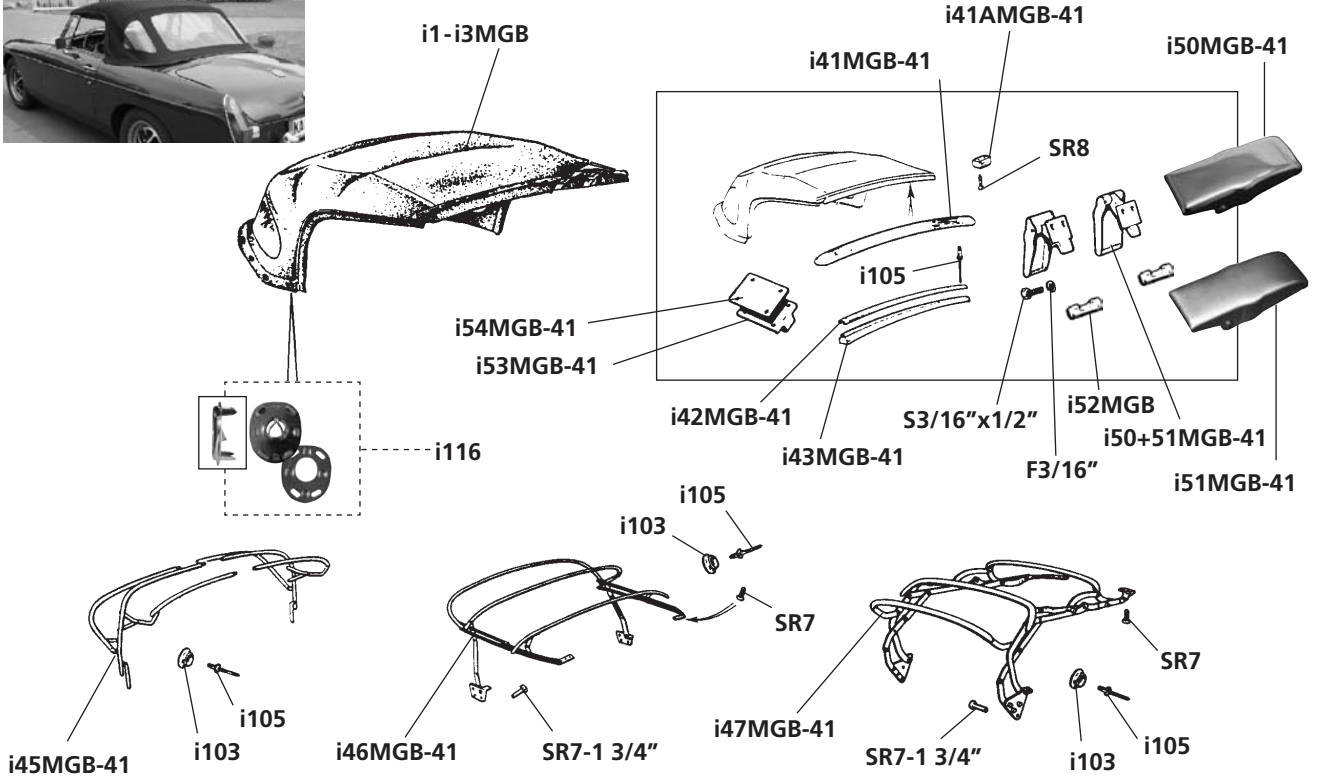

No.	Bezeichnung	Description	Anzahl/Qty.
i4AMGB	Haltegestänge Verdeckabdeckung	Cockpit rail covering kit	1
i75MGB	Dreipunkt-Automatik-Sicherheitsgurt	Seat belt 3 point automatic	2
i76SPT	Zweipunkt-Beckengurt universal	Universal static belt 2 point	A/R
i90MGB	Tasche Spritzdecke grau	Bag tonneau cover grey twill	1
i100	Verdeckdruckknopf außen chrom	Button hood outer fixing chrome	A/R
i101	Verdeckdruckknopf außen schwarz	Button hood outer fixing black	A/R
i102	Verdeckdruckknopf Oberteil unten	Button hood upper	A/R
i103	Verdeckdruckknopf Unterteil	Button hood lower	A/R
i104	Druckknopf Unterteil Gegenstück	Eyelet, button hood lower	A/R
i116	Lift-A-Dot Verdeckknopf-Oberteil	Lift-A-Dot hood fastener	A/R
WZ60	Druckknopf Montagewerkzeug	Button hood fixing tool	1
Verdeckabdeckungen		Hood covers	
i4MGB	Verdeckabdeckung PVC schwarz	Hood cover PVC black	1
i5MGB	Verdeckabdeckung Canvas Stoff schwarz	Hood cover Canvas black	1
i6MGB	Verdeckabdeckung Mohair Stoff schwarz	Hood cover Mohair black	1
Persenning ohne Nackenstütze (Chromstoßstange)		Tonneau covers w/o headrest (Chrome bumper)	
i7MGB/CB	Persenning PVC schwarz	Tonneau cover PVC black	1
i8MGB/CB	Persenning Canvas Stoff schwarz	Tonneau cover Canvas black	1
i9MGB/CB	Persenning Mohair Stoff schwarz	Tonneau cover Mohair black	1
Persenning ohne Nackenstütze (Gummistoßstange)		Tonneau covers w/o headrest (Rubber bumper)	
i7MGB/RB	Persenning PVC schwarz	Tonneau cover PVC black	1
i8MGB/RB	Persenning Canvas Stoff schwarz	Tonneau cover Canvas black	1
i9MGB/RB	Persenning Mohair Stoff schwarz	Tonneau cover Mohair black	1
Persenning mit Nackenstütze (Chromstoßstange)		Tonneau covers with headrest (Chrome bumper)	
i10MGB/CB	Persenning mit Nackenstütze PVC schwarz	Tonneau cover with headrest PVC black	1
i11MGB/CB	Persenning mit Nackenstütze Canvas Stoff schwarz	Tonneau cover with headrest Canvas black	1
i12MGB/CB	Persenning mit Nackenstütze Mohair Stoff schwarz	Tonneau cover with headrest Mohair black	1
Persenning mit Nackenstütze (Gummistoßstange)		Tonneau covers with headrest (Rubber bumper)	
i10MGB/RB	Persenning mit Nackenstütze PVC schwarz	Tonneau cover with headrest PVC black	1
i11MGB/RB	Persenning mit Nackenstütze Canvas Stoff schwarz	Tonneau cover with headrest Canvas black	1
i12MGB/RB	Persenning mit Nackenstütze Mohair Stoff schwarz	Tonneau cover with headrest Mohair black	1

**Hinweis
Note:**

Unsere Persenning werden mit allen Befestigungsknöpfen spritzdeckenseitig geliefert, verfügen über einen Mittelreißverschluss und sind auch für rechtsgelenkte Fahrzeuge lieferbar.

Every tonneau cover contents all fitting materials (for the tonneau). All tonneau cover have a centre zip and are also available for rhd cars.



Verdeckabdeckung / Hood Cover in PVC



Persenning / Tonneau Cover in Canvas

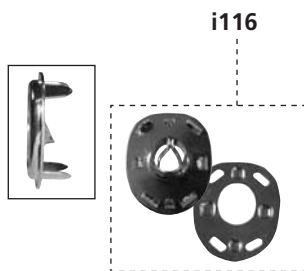
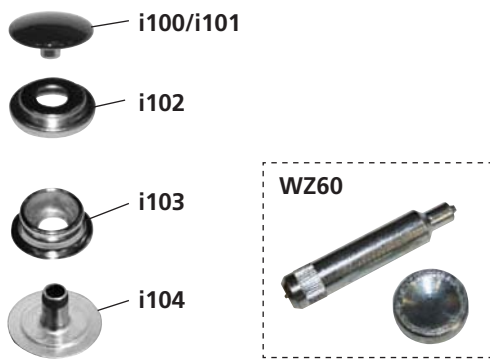
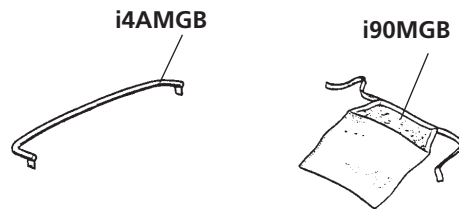
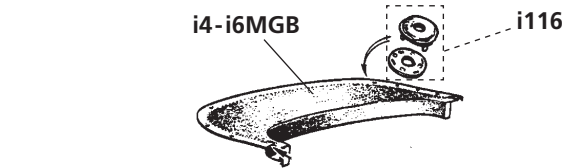
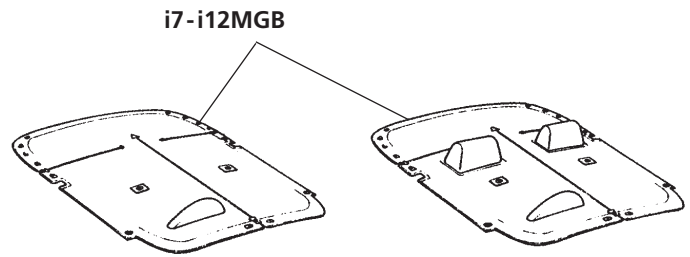
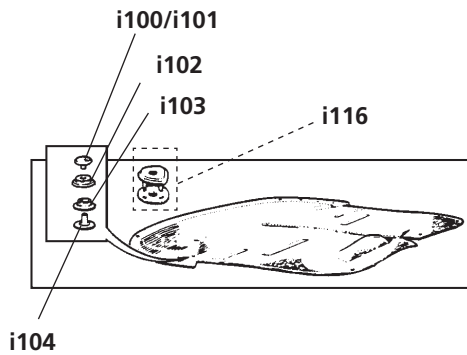

Roadster

i125MGB

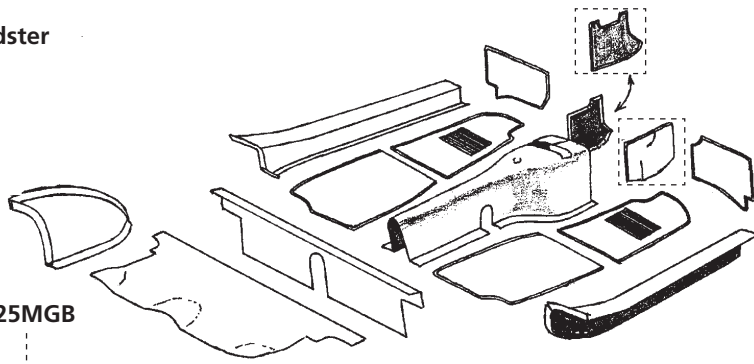
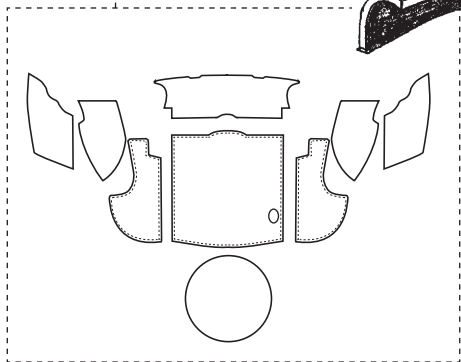

GT

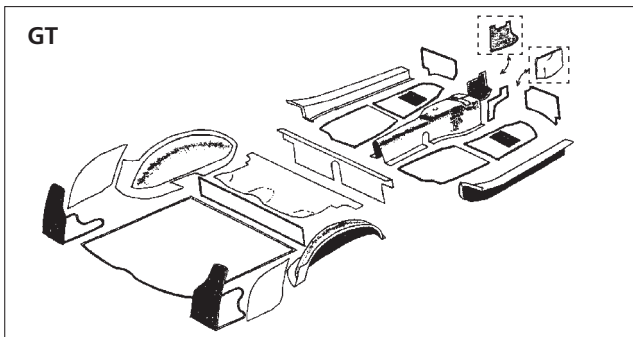

Hinweis
Note:



Farbige Teppichsätze auf Anfrage!
Bitte beachten Sie bei Sonderanfertigungen: (längere)
Lieferzeiten ca. 6-8 Wochen

Coloured carpet sets on demand!
Please note: (longer) time of delivery
ca. 6-8 weeks



beige



blau / blue



braun / brown



grün / green

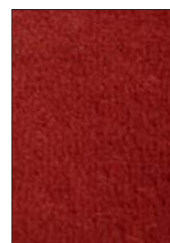

rot / red

Schutzmatten / Overmats



i105MGB



i115AMGB



i116AMGB

Roadster		Roadster	
No.	Bezeichnung	Description	Anzahl/Qty.
i100MGB	Teppichsatz schwarz Velours, genäht bis 67	Carpet set black Velours, sewed up to 67	1
i100AMGB	Teppichsatz schwarz Velours, genäht ab 67	Carpet set black Velours, sewed 67 on	1
i110MGB	Teppichsatz schwarz vorgeformt 62-68, 3-Synchro	Carpet set black Velours, moulded 62-68, 3-synchro	1
i110AMGB	Teppichsatz schwarz vorgeformt 69-81	Carpet set black Velours, moulded 69-81	1
i120MGB	Filz-Dämmmattensatz unter Teppich bis 67	Felt mat kit under carpet up to 67	1
i120AMGB	Filz-Dämmmattensatz unter Teppich ab 71	Felt mat kit under carpet 71 on	1
i125MGB	Kofferraum Ausstattungs-Kit 9-teilig	Boot lid carpet and panel kit, 9 pieces	1
i105MGB	Paar Gummifußmatten, 3-Synchro	Rubber floor mats, pair 3-synchro	1
i105AMGB	Paar Gummifußmatten, 4-Synchro	Rubber floor mats, pair 4-synchro	1
i115MGB	Paar Schmutzmatten, 3-Synchro	Overmats, pair 3-synchro	1
i115AMGB	Paar Schmutzmatten mit MG Logo, 3-Synchro	Overmats with MG-logo, pair 3-synchro	1
i116MGB	Paar Schmutzmatten, 4-Synchro	Overmats, pair 4-synchro	1
i116AMGB	Paar Schmutzmatten mit MG Logo, 4-Synchro	Overmats with MG-logo, pair 4-synchro	1
GT		GT	
i101MGB	Teppichsatz schwarz Velours, genäht GT bis 67	Carpet set black Velours, sewed GT up to 67	1
i101AMGB	Teppichsatz schwarz Velours, genäht GT ab 67	Carpet set black Velours, sewed GT 67 on	1
i111MGB	Teppichsatz schwarz vorgeformt GT 62-68, 3-Synchro	Carpet set black Velours, moulded GT 62-68, 3-synchro	1
i111AMGB	Teppichsatz schwarz vorgeformt GT 69-81	Carpet set black Velours, moulded GT 69-81	1
i121MGB	Filz-Dämmmattensatz unter Teppich GT bis 67	Felt mat kit under carpet GT up to 67	1
i121AMGB	Filz-Dämmmattensatz unter Teppich GT ab 67	Felt mat kit under carpet GT 67 on	1
Schutzmatten		Overmats	
i105MGB	Paar Gummifußmatten, 3-Synchro	Rubber floor mats, pair 3-synchro	1
i105AMGB	Paar Gummifußmatten, 4-Synchro	Rubber floor mats, pair 4-synchro	1
i115AMGB	Paar Schmutzmatten mit MG Logo, 3-Synchro	Overmats with MG-logo, pair 3-synchro	1
i116AMGB	Paar Schmutzmatten mit MG Logo, 4-Synchro	Overmats with MG-logo, pair 4-synchro	1

Sitze/-bezüge		Seats/seat covers	
No.	Bezeichnung	Description	Anzahl/Qty.
i30MGBL	Sitzbezüge Leder, Paar (3-Synchro)	Front seat covering kit - Leather - Pair (3-Synchro)	1
i30MGB	Sitzbezüge Vinyl, Paar (3-Synchro)	Front seat covering kit - Vinyl - Pair (3-Synchro)	1
i30CMGBL	Sitzbezüge Leder, Paar (4 Synchro)	Front seat covering kit - Leather - Pair (4 Synchro)	1
i30CMGB	Sitzbezüge Vinyl, Paar (4 Synchro)	Front seat covering kit - Vinyl - Pair (4 Synchro)	1
i31MGB	Schaumpolster Rückenlehne (3-Synchro)	Squab foam cushion (3-Synchro)	2
i31CMGB	Schaumpolster Rückenlehne (4 Synchro)	Squab foam cushion (4 Synchro)	2
i32MGB/R	Schaumpolster Sitzunterteil, rechts (3-Synchro)	Base foam cushion - RH (3-Synchro)	1
i32MGB/L	Schaumpolster Sitzunterteil, links (3-Synchro)	Base foam cushion - LH (3-Synchro)	1
i32CMGB/R	Schaumpolster Sitzunterteil, rechts (4 Synchro)	Base foam cushion - RH (4 Synchro)	1
i32CMGB/L	Schaumpolster Sitzunterteil, links (4 Synchro)	Base foam cushion - LH (4 Synchro)	1
i33MGB	Pappe hinter Rückenpolster (3-Synchro)	Squab backboard (3-Synchro)	2
i33CMGB	Pappe hinter Rückenpolster (4 Synchro)	Squab backboard (4 Synchro)	2
i34MGB	Spannmatte unter Sitz	Base seat diaphragm	2

Innenausstattungssteile		Interior trim parts	
i35MGB	Verkleidung Fußraum, Paar	Pair of Scuttle panels	1
i36MGB	Türverkleidung, Paar (3-Synchro 62-64)	Pair of Door panels (3-Synchro 62-64)	1
i36AMGB	Türverkleidung, Paar (3-Synchro 65-68)	Pair of Door panels (3-Synchro 65-68)	1
i36CMGB	Türverkleidung, Paar (4 Synchro)	Pair of Door panels (4 Synchro)	1
i37MGB	Verkleidung Radkasten, Paar (3-Synchro)	Pair of wheel arch panels (3-Synchro)	1
i37CMGB	Verkleidung Radkasten, Paar (4 Synchro)	Pair of wheel arch panels (4 Synchro)	1
i38MGB	Verkleidungsteil Rückwand	Rear cockpit panel	1
i39MGB	Obere Türverkleidungen, Paar (3-Synchro 62-64)	Pair Door Cappings (3-Synchro 62-64)	1
i39AMGB	Obere Türverkleidungen, Paar (3-Synchro 65-68, 4-Synchro)	Pair Door Cappings (3-Synchro 65-68, 4-Synchro)	1
i40MGB	Cockpitleiste oben hinter den Sitzen	Cockpit rail covering kit	1
i41MGB/RHD	Handschuhfach RHD	Glove box - RHD	1
i41MGB/LHD	Handschuhfach LHD	Glove box - LHD	1
i42MGB	Schutzleiste Armaturenbrett	Dash top cover & crash pad rail complete	1
i43MGB	Verkleidung Heizungsgehäuse	Heater box trim panel	1
i44MGB	Schalthebelbezug Vinyl	Vinyl gear lever gaiter	1
i44MGBL	Schalthebelbezug Leder	Leather gear lever gaiter	1
i65MGB	Satz Sonnenblenden komplett mit Haltegummis, Roadster (auch für Fzge. ohne Sonnenblenden)	Set sunvisors with fixing, Roadster models (also for cars not equipped with sunvisors)	1
i75MGB	Dreipunkt-Automatik-Sicherheitsgurt (TÜV gepr. mit "E"-Zeichen)	Seat belt 3 point automatic (German TÜV approved)	2
i76SPT	Zweipunkt-Beckengurt universal	Universal static belt 2 point	A/R

Innenausstattungen Sets		Interior trim panel kits	
i47MGB/10	Innenausstattung komplett, 10-teilig, (3-Synchro 62-64)	10 Piece trim panel kit (3-Synchro 62-64)	1
i47AMGB/10	Innenausstattung komplett, 10-teilig, (3-Synchro 65-68)	10 Piece trim panel kit (3-Synchro 65-68)	1
i47CMGB/10	Innenausstattung komplett, 10-teilig, (4 Synchro)	10 Piece trim panel kit (4 Synchro)	1

Befestigungsmaterial		Interior trim fixings	
i150	Teppich Druckknopf	Carpet fastener	A/R
i103	Teppich-Befestigungsknopf Gegenstück auf Karosserie usw.	Stud hood rear (on body)	A/R
i105	Popniete zur Befestigung von i103	Rivet imex	A/R
i110	Clip Sitzbezug	Clip tubular seat cover/frame	A/R
i160	Schraube und Rosette zur Befestigung Innenverkleidungen	Screw and chrom cap washer for fitting interieur trim	A/R
i170MGB	Befestigungsclip Türverkleidung	Clip, door trim	A/R
i171MGB	Gegenstück Clip Türverkleidung	Flanges cup to clip no. i170MGB	A/R
i172MGB	Befestigungsclip	Clip	A/R
i173MGB	Gegenstück für Befestigungsclip i172MGB	Flanged cup to clip no. i172MGB	A/R

Hinweis 
Note:

Innenausstattungen in schwarzer Ausführung. Interior trim parts in black colour.
 Farbige Innenausstattung auf Anfrage! Coloured interior trim parts on demand!
 Bitte beachten Sie bei Sonderanfertigungen: (längere) Lieferzeiten ca. 6-8 Wochen
 Please note: (longer) time of delivery ca. 6-8 weeks

Befestigungsmaterial / Interior trim fixings

i150
i105
i103
i110TR
i160
i170MGB
i171MGB
i172MGB
i173MGB

Sitze/-bezüge		Seats/seat covers	
No.	Bezeichnung	Description	Anzahl/Qty.
i30GMGB	Sitzbezüge, 1/2 Bereich perforiert, Paar (70-73)	Front seat covering kit - 1/2 perforated seat faces - Pair (70-73)	1
i30AGMGB	"D" Type Kopfstütze kompl., 1/2 Bereich perforiert, Vinyl (70-73)	"D" type headrest - complete, 1/2 perforated Vinyl (70-73)	2
i30BGMGB	"D" Type Kopfstütze Bezug, 1/2 Bereich perforiert, Vinyl (70-73)	"D" type headrest - cover - 1/2 perforated Vinyl (70-73)	2
i30KMGB	Sitzbezüge, 3/4 Bereich perforiert, Paar (ab 73)	Front seat covering kit - 3/4 perforated seat faces - Pair (73 on)	1
i30AKMGB	"D" Type Kopfstütze komplett, Voll-Vinyl (ab 73)	"D" type headrest - complete, plain Vinyl (73 on)	2
i30BKMGB	"D" Type Kopfstütze Bezug, Voll-Vinyl (ab 73)	"D" type headrest - cover - plain Vinyl (73 on)	2
i30MMGB	Sitzbezüge, ganz Stoff, Paar (73-76)	Front seat covering kit - Full cloth faces - Pair (73-76)	1
i30NMGB	Sitzbezüge, ganz Stoff, Paar (76-80)	Front seat covering kit - Full cloth faces - Pair (76-80)	1
i31GMGB	Schaumpolster Rückenlehne	Squab foam	2
i32CMGB/R	Schaumpolster Sitzunterteil, rechts (70-73)	Base foam cushion - RH, (70-73)	1
i32CMGB/L	Schaumpolster Sitzunterteil, links (70-73)	Base foam cushion - LH, (70-73)	1
i32KMGB/R	Schaumpolster Sitzunterteil, rechts (ab 73)	Base foam cushion - RH (73 on)	1
i32KMGB/L	Schaumpolster Sitzunterteil, links (ab 73)	Base foam cushion - LH (73 on)	1
i33GMGB	Pappe hinter Rückenpolster	Squab backboard	2
i34GMGB	Spannmatte unter Sitz	Base seat diaphragm	1

Innenausstattungssteile		Interior trim parts	
i35GMGB	Verkleidung Fußraum, Paar	Pair of Scuttle panels	1
i36GMGB	Türverkleidung, Paar ohne Chrom (70-71)	Pair of Door panels - no chrome strips (70-71)	1
i36GMGB/CHR	Türverkleidung, Paar mit Chromstreifen (72-76)	Pair of Door panels - with chrome strips (72-76)	1
i36NMGB/CHR	Türverkleidung, Paar mit Chromstreifen (ab 76)	Pair of Door panels- with chrome strips (76 on)	1
i37GMGB	Verkleidung Radkasten, Paar	Pair of wheel arch panels	1
i38GMGB	Verkleidungsteil Rückwand	Rear cockpit panel	1
i39GMGB	Obere Türverkleidungen, Paar	Pair Door Cappings	1
i40GMGB	Cockpitleiste oben hinter den Sitzen	Cockpit rail covering kit	1
i41MGB/RHD	Handschuhfach RHD	Glove box - RHD	1
i41MGB/LHD	Handschuhfach LHD	Glove box - LHD	1
i42MGB	Schutzleiste Armaturenbrett	Dash top cover & crash pad rail complete	1
i43GMGB	Verkleidung Heizungsgehäuse	Heater box trim panel	1
i44MGB	Schalthebelbezug Vinyl	Vinyl gear lever gaiter	1
i44MGBL	Schalthebelbezug Leder	Leather gear lever gaiter	1
i45MGB	Mittelarmkonsole Vinyl, schwarz	Centre console lid - Vinyl - Black	1
i45MGBL	Mittelarmkonsole Leder, schwarz	Centre console lid - Leather - Black	1
i65MGB/L	Sonnenblende links Roadster ab 1976	Sunvisor LHD Roadster models from 1976	1
i65MGB/R	Sonnenblende rechts Roadster ab 1976	Sunvisor RHD Roadster models from 1976	1
i65MGB	Satz Sonnenblenden komplett mit Haltegummis, Roadster (auch für Fzge. ohne Sonnenblenden)	Set sunvisors with fixing, Roadster models (also for cars not equipped with sunvisors)	1
i65AMGB	Sonnenblende Roadster 1970-76	Sunvisor Roadster models 1970-76	2
i75MGB	Dreipunkt-Automatik-Sicherheitsgurt (TÜV gepr. mit "E"-Zeichen)	Seat belt 3 point automatic (German TÜV approved)	2
i76SPT	Zweipunkt-Beckengurt universal	Universal static belt 2 point	A/R

Innenausstattungen Sets		Interior trim panel kits	
i47GMGB/10	Innenausstattung komplett, 10-teilig ohne Chrom (70-71)	10 Piece trim panel kit no chrome (70-71)	1
i47MMGB/10	Innenausstattung komplett, 10-teilig ohne Chrom (76-80)	10 Piece trim panel kit no chrome (76-80)	1
i47GMGB/10CHR	Innenausstattung komplett, 10-teilig mit Chromstreifen (ab 72)	10 Piece trim panel kit with chrome strips (72 on)	1

Innenausstattungen Sets Leder		Interior trim panel kits leather	
i48KMGB/10	Innenausstattung Leder komplett, 10-teilig (70-72)	10 Piece trim panel kit, leather (70-72)	1
i48KMGB/10CHR	Innenausstattung Leder komplett, 10-teilig mit Chromstreifen (73-76)	10 Piece trim panel kit, leather with chrome strips (73-76)	1
i48NMGB/10	Innenausstattung Leder komplett, 10-teilig (ab 76)	10 Piece trim panel kit, leather (76 on)	1

Befestigungsmaterial s. Seite 112-113

Interior trim fixings - s. page 112-113

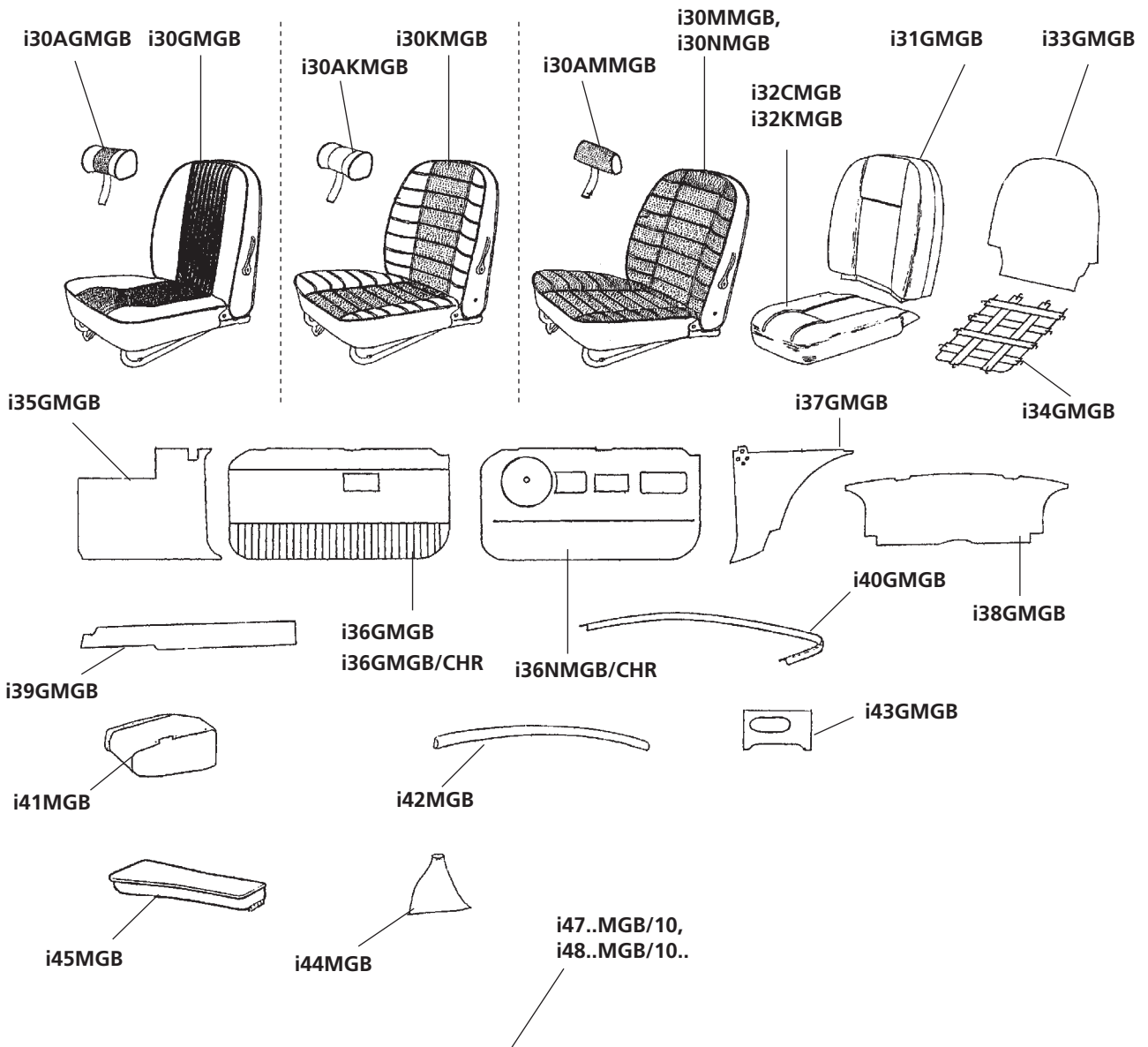

Hinweis 
Note:

Innenausstattungen in schwarzer Ausführung.
Farbige Innenausstattung auf Anfrage!
Bitte beachten Sie bei Sonderanfertigungen:
(längere) Lieferzeiten ca. 6-8 Wochen

Interior trim parts in black colour.
Coloured interior trim parts on
demand! Please note: (longer)
time of delivery ca. 6-8 weeks

Sitze/-bezüge		Seats/seat covers	
No.	Bezeichnung	Description	Anzahl/Qty.
i30MGBL	Sitzbezüge Leder, Paar (3-Synchro)	Front seat covering kit - Leather - Pair (3-Synchro)	1
i30MGB	Sitzbezüge Vinyl, Paar (3-Synchro)	Front seat covering kit - Vinyl - Pair (3-Synchro)	1
i30CMGBL	Sitzbezüge Leder, Paar (4-Synchro)	Front seat covering kit - Leather - Pair (4-Synchro)	1
i30CMGB	Sitzbezüge Vinyl, Paar (4-Synchro)	Front seat covering kit - Vinyl - Pair (4-Synchro)	1
i31MGB	Schaumpolster Rückenlehne (3-Synchro)	Squab foam cushion (3-Synchro)	2
i31CMGB	Schaumpolster Rückenlehne (4-Synchro)	Squab foam cushion (4-Synchro)	2
i32MGB/R	Schaumpolster Sitzunterteil, rechts (3-Synchro)	Base foam cushion - RH (3-Synchro)	1
i32MGB/L	Schaumpolster Sitzunterteil, links (3-Synchro)	Base foam cushion - LH (3-Synchro)	1
i32CMGB/R	Schaumpolster Sitzunterteil, rechts (4-Synchro)	Base foam cushion - RH (4-Synchro)	1
i32CMGB/L	Schaumpolster Sitzunterteil, links (4-Synchro)	Base foam cushion - LH (4-Synchro)	1
i33MGB	Pappe hinter Rückenpolster (3-Synchro)	Squab backboard (3-Synchro)	2
i33CMGB	Pappe hinter Rückenpolster (4-Synchro)	Squab backboard (4-Synchro)	2
i34MGB	Spannmatte unter Sitz	Base seat diaphragm	2
i60MGBL	Sitzbezüge Rückbank Leder (3-Synchro)	Rear seat covering kit - Leather (3-Synchro)	1
i60MGB	Sitzbezüge Rückbank Vinyl (3-Synchro)	Rear seat covering kit - Vinyl (3-Synchro)	1
i60DMGBL	Sitzbezüge Rückbank Leder (4-Synchro)	Rear seat covering kit - Leather (4-Synchro)	1
i60DMGB	Sitzbezüge Rückbank Vinyl (4-Synchro)	Rear seat covering kit - Vinyl (4-Synchro)	1
i61MGB	Schaumpolster Teile Rückbank	Rear seat foam kit	1

Innenausstattungsteile		Interior trim parts	
i35MGB	Verkleidung Fußraum, Paar	Pair of Scuttle panels	1
i36BMGB	Türverkleidung, Paar (3-Synchro)	Pair of Door panels (3-Synchro)	1
i36CMGB	Türverkleidung, Paar (4-Synchro)	Pair of Door panels (4-Synchro)	1
i37BMGB	Verkleidung Radkasten, Paar (3-Synchro)	Pair of wheel arch panels (3-Synchro)	1
i37DMGB	Verkleidung Radkasten, Paar (4-Synchro)	Pair of wheel arch panels (4-Synchro)	1
i39BMGB	Obere Türverkleidungen, Paar	Pair Door Cappings	1
i41MGB/RHD	Handschuhfach RHD	Glove box - RHD	1
i41MGB/LHD	Handschuhfach LHD	Glove box - LHD	1
i42MGB	Schutzleiste Armaturenbrett	Dash top cover & crash pad rail complete	1
i43MGB	Verkleidung Heizungsgehäuse	Heater box trim panel	1
i44MGB	Schalthebelbezug Vinyl	Vinyl gear lever gaiter	1
i44MGBL	Schalthebelbezug Leder	Leather gear lever gaiter	1
i62MGB	Heckverkleidungssatz (o. Abb.)	Tailgate panels (w/o illustr.)	1
i63MGB	Obere Verkleidungsteile hinter C-Säule, komplett	Rear quarter capping - complete	1
i64MGB	Verkleidung C-Säule, grau	"C" post panel kit, grey	1
i65MGB	Satz Sonnenblenden komplett mit Haltegummis, Roadster (auch für Fzge. ohne Sonnenblenden)	Set sunvisors with fixing, Roadster models (also for cars not equipped with sunvisors)	1
i65MGB/GT	Sonnenblende grau mit Haltern GT	Grey sunvisor with fixings GT models	2
i66MGB	Verkleidung A-Säule	"A" post panel kit	1
i75MGB	Dreipunkt-Automatik-Sicherheitsgurt (TüV gepr. mit "E"-Zeichen)	Seat belt 3 point automatic (German TÜV approved)	2

Innenausstattungen Sets		Interior trim panel kits	
i47BMGB/10	Innenausstattung komplett, 10-teilig (3-Synchro)	10 Piece trim panel kit (3-Synchro)	1
i47DMGB/10	Innenausstattung komplett, 10-teilig (4-Synchro)	10 Piece trim panel kit (4-Synchro)	1

Innenausstattungen Sets Leder		Interior trim panel kits leather	
i48KMGB/10	Innenausstattung Leder komplett, 10-teilig (1970-72)	10 Piece trim panel kit leather (1970-72)	1
i48KMGB/10CHR	Innenausstattung Leder komplett, 10-teilig mit Chromstreifen (1973-76)	10 Piece trim panel kit leather with chrome strips (1973-76)	1
i48NMGB/10	Innenausstattung Leder komplett, 10-teilig (ab 1976)	10 Piece trim panel kit leather (1976 on)	1

Befestigungsmaterial s. Seite 112-113

Interior trim fixings - s. page 112-113

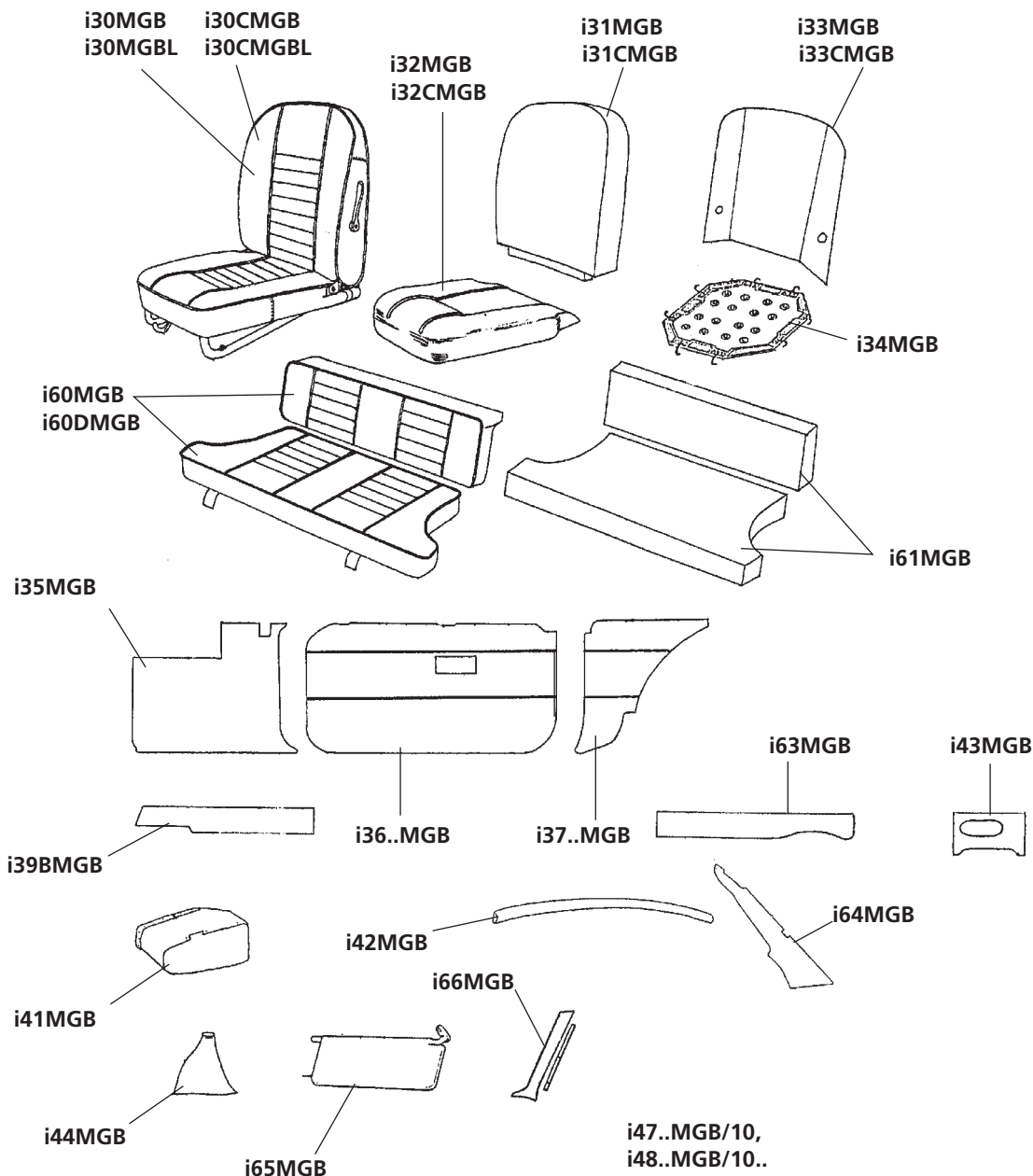

Hinweis 

Note:
Innenausstattungen in schwarzer Ausführung.
Farbige Innenausstattung auf Anfrage!
Bitte beachten Sie bei Sonderanfertigungen:
(längere) Lieferzeiten ca. 6-8 Wochen

Interior trim parts in black colour.
Coloured interior trim parts on
demand! Please note: (longer)
time of delivery ca. 6-8 weeks

Sitze/-bezüge		Seats/seat covers	
No.	Bezeichnung	Description	Anzahl/Qty.
i30GMGB	Sitzbezüge 1/2 Bereich perforiert, Paar (70-73)	Front seat covering kit - 1/2 perforated centres - Pair (70-73)	1
i30HMGB	Sitzbezüge 1/2 Bereich Stoff, Paar (71-73)	Front seat covering kit - 1/2 Cloth centres - Pair (71-73)	1
i30AGMGB	"D" Type Kopfstütze kompl., Vinyl - 1/2 Bereich perforiert (70-73)	"D" type headrest - complet - 1/2 perforated vinyl (70-73)	2
i30BGMGB	"D" Type Kopfstütze Bezug Vinyl - 1/2 Bereich perforiert (70-73)	"D" type headrest cover - 1/2 perforated vinyl (70-73)	2
i30MMGB	Sitzbezüge Sitzbereich ganz Stoff, Paar (73-76)	Front seat covering kit - Full cloth faces (73-76)	1
i30NMGB	Sitzbezüge Sitzbereich ganz Stoff, Paar (76-80)	Front seat covering kit - Full cloth faces (76-80)	1
i30AKMGB	"D" Type Kopfstütze komplett, Voll-Vinyl (73-76)	"D" type headrest - complet - plain vinyl (73-76)	2
i30BKMGB	"D" Type Kopfstütze Bezug Voll-Vinyl (73-76)	"D" type headrest cover - plain vinyl (73-76)	2
i30ANMGB	"Peardrop" Kopfstütze komplett, Voll-Vinyl (76-80)	Peardrop headrest complete - plain vinyl (76-80)	2
i30BNMGB	"Peardrop" Kopfstütze Bezug Voll-Vinyl (76-80)	Peardrop headrest cover - plain vinyl (76-80)	2
i31GMGB	Schaumpolster Rückenlehne	Squab foam cushion	2
i32CMGB/R	Schaumpolster Sitzunterteil, rechts (70-73)	Base foam cushion - RH	1
i32CMGB/L	Schaumpolster Sitzunterteil, links (70-73)	Base foam cushion - LH	1
i32KMGB/R	Schaumpolster Sitzunterteil, rechts (ab 73)	Base foam cushion - RH	1
i32KMGB/L	Schaumpolster Sitzunterteil, links (ab 73)	Base foam cushion - LH	1
i33GMGB	Pappe hinter Rückenpolster	Squab backboard	2
i34GMGB	Spannmatte unter Sitz	Base seat diaphragm	2
i60HMGB	Sitzbezüge Rückbank 1/2 Bereich perforiert	Rear seat covering kit - 1/2 perforated centres	1
i60AHMGB	Sitzbezüge Rückbank 1/2 Bereich Stoff	Rear seat covering kit - 1/2 Cloth centres	1
i60LMGB	Sitzbezüge Rückbank Sitzbereich ganz Stoff	Rear seat covering kit - Full cloth faces	1
i61MGB	Schaumpolster Teile Rückbank	Rear seat foam kit	1
Innenausstattungsteile		Interior trim parts	
i35GMGB	Verkleidung Fußraum, Paar	Pair of Scuttle panels	1
i35NMGB	Verkleidung Fußraum, Paar (ab 76)	Pair of Scuttle panels (76 on)	1
i36GMGB	Türverkleidung, Paar ohne Chrom (70-71)	Pair of Door panels - no chrome (70-71)	1
i36GMGB/CHR	Türverkleidung, Paar mit Chromstreifen (ab 72)	Pair of Door panels - with chrome strips (72 on)	1
i36NMGB/CHR	Türverkleidung, Paar mit Chromstreifen (ab 76)	Pair of Door panels - with chrome strips (76 on)	1
i37HMGB	Verkleidung Radkasten, Paar	Pair of wheel arch panels	1
i37NMGB	Verkleidung Radkasten, Paar (ab 76)	Pair of wheel arch panels (76 on)	1
i39HMGB	Obere Türverkleidungen, Paar	Pair Door Cappings	1
i39BMGB	Obere Türverkleidungen, Paar (ab 76)	Pair Door Cappings (76 on)	1
i41MGB/RHD	Handschuhfach RHD	Glove box - RHD	1
i41MGB/LHD	Handschuhfach LHD	Glove box - LHD	1
i42MGB	Schutzleiste Armaturenbrett	Dash top cover & crash pad rail complete	1
i43CMGB	Verkleidung Heizungsgehäuse (70-76)	Heater box trim panel (70-76)	1
i43GMGB	Verkleidung Heizungsgehäuse (ab 76)	Heater box trim panel (76 on)	1
i44MGB	Schalthebelbezug Vinyl	Vinyl gear lever gaiter	1
i44MGBL	Schalthebelbezug Leder	Leather gear lever gaiter	1
i45MGB	Mittelarmkonsole Vinyl schwarz	Centre console lid - Vinyl - Black	1
i45MGBL	Mittelarmkonsole Leder schwarz	Centre console lid - Leather - Black	1
i62NMGB	Heckverkleidungssatz (70-76)	Tailgate panels (70-76)	1
i62MGB	Heckverkleidungssatz (ab 76)	Tailgate panels (76 on)	1
i63HMGB	Obere Verkleidungsteile hinter C-Säule, komplett	Rear quarter capping - complete	1
i63NMGB	Obere Verkleidungsteile hinter C-Säule, komplett (ab 76)	Rear quarter capping - complete (76 on)	1
i64MGB/GT	Verkleidung C-Säule, grau GT	"C" post panel kit, grey GT models	1
i64NMGB	Verkleidung C-Säule, grau (ab 76)	"C" post panel kit, grey (76 on)	1
i65MGB	Paar Sonnenblenden komplett mit Haltegummis (auch für Fzge. ohne Sonnenblenden)	Pair sunvisors with fixings (also for cars not equipped with sunvisors)	1
i65AMGB	Satz Sonnenblenden Roadster LHD (1970-76)	Set sunvisors Roadster LHD (1970-76)	1
i65MGB/GT	Sonnenblende grau mit Haltern GT	Grey sunvisor with fixings GT models	2
i65NMGB/LHDL	Sonnenblende grau mit Haltern links, LHD (ab 76) GT	Grey/Black sunvisor with fixings LH, LHD (76 on) GT models	1
i65NMGB/LHDR	Sonnenblende grau mit Haltern rechts, LHD (ab 76) GT	Grey/Black sunvisor with fixings RH, LHD (76 on) GT models	1
i66MGB	Verkleidung A-Säule, Paar	"A" post panel kit (pair)	1
i61TR6	Dreipunkt-Automatik-Sicherheitsgurt (TüV gepr. mit "E"-Zeichen)	Seat belt 3 point automatic (German TÜV approved)	2
Innenausstattungen Sets		Interior trim panel kits	
i47KMGB/10	komplett, 10-teilig (70-72)	10 Piece trim panel kit (70-72)	1
i47KMGB/10CHR	komplett, 10-teilig mit Chromstreifen (73-76)	10 Piece trim panel kit with chrome strips (73-76)	1
i47NMGB/10	komplett, 10-teilig (ab 76)	10 Piece trim panel kit (76 on)	1
Innenausstattungen Sets Leder		Interior trim panel kits leather	
i48KMGB/10	Leder komplett, 10-teilig (70-72)	10 Piece trim panel kit leather (70-72)	1
i48KMGB/10CHR	Leder komplett, 10-teilig mit Chromstreifen (73-76)	10 Piece trim panel kit leather with chrome strips (73-76)	1
i48NMGB/10	Leder komplett, 10-teilig (ab 76)	10 Piece trim panel kit leather (76 on)	1

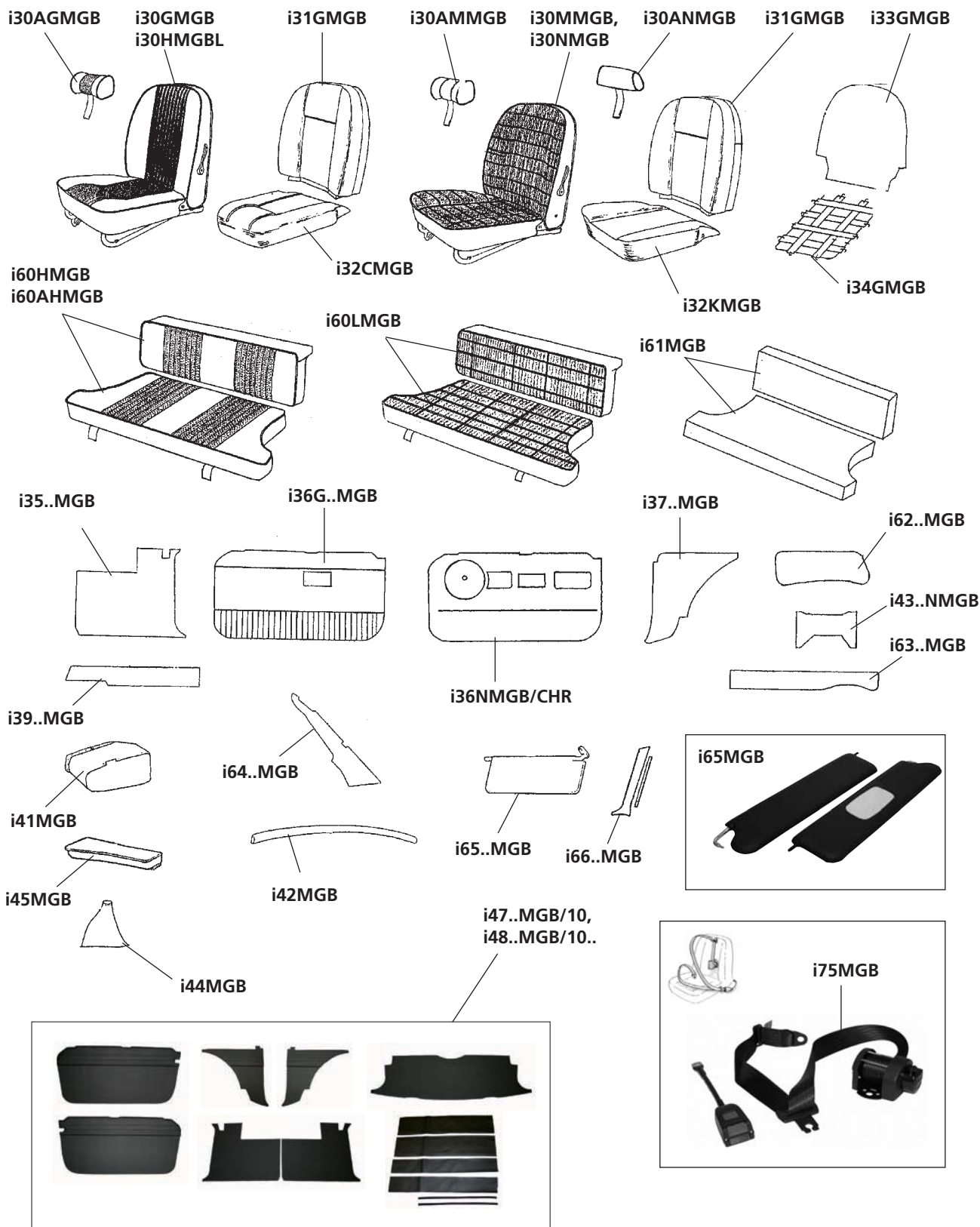

Hinweis  **Note:**

Innenausstattungen in schwarzer Ausführung.
 Farbige Innenausstattung auf Anfrage!
 Bitte beachten Sie bei Sonderanfertigungen:
 (längere) Lieferzeiten ca. 6-8 Wochen

Interior trim parts in black colour.
 Coloured interior trim parts on
 demand! Please note: (longer)
 time of delivery ca. 6-8 weeks

Befestigungsmaterial s. Seite 112-113

Interior trim fixings - s. page 112-113

Roadster		Roadster	
No.	Bezeichnung	Description	Anzahl/Qty.
R1MGB	Frontscheibe klar	Glass windscreen clear	1
R1AMGB	Frontscheibe grün getönt	Glass windscreen tinted, green	1
R2MGB	Gummi-Dichtung Frontscheibe unten	Rubber seal frontscreen lower	1
R3AMGB	Gummi-A-Säule *)	Pillar rubber *)	1/1
R4AMGB	Senkkopf-Schraube lang im Rahmen oben	Countersunk screw long (frame upper)	4
R4BMGB	Schraube Senkkopf kurz im Rahmen oben	Countersunk screw short (frame upper)	4
R5MGB	Frontscheibengummi	Seal glass to frame	1
R6MGB	Halter Dichtung	Retainer seal	2
R6AMGB	Halteleiste Dichtung innen	Retainer pillar seal	2
R7MGB	Dichtleiste Scheibe/Türe	Sealing strip frontscreen/pillar	2
R40MGB	Versteifungsteil unten	Strengthening lower corner	2
i52MGB	Verdeckhalterung an Frontscheibenrahmen	Bracket, hood fastening	2
R66MGB	Rahmenplatte außen	Packing, outer (pillar)	2
R67MGB	Rahmenplatte innen	Packing, inner (pillar)	2
R68MGB	Halteplatte Innenspiegel bis 68	Bracket rear view mirror up to 68	1
R68AMGB	Halteplatte Innenspiegel ab 69	Bracket rear view mirror from 69 on	1
R68BMGB	Halteplatte Innenspiegel ab 70	Bracket rear view mirror from 70 on	1
R69MGB	Halter Sonnenblende innen	Bracket sun visor anchor	2
R69AMGB	Halter Sonnenblende aussen	Bracket sun visor pivot	2
S3/16"x7/16"SK	Senkkopfschraube 3/16"x7/16"UNF	Countersunk screw 3/16"x7/16"UNF	4

GT		GT	
R1MGB/GT	Frontscheibe klar	Glass windscreen clear	1
R1AMGB/GT	Frontscheibe grün getönt	Glass windscreen tinted, green	1
S1MGB/GT	Dachleiste MGB-GT chrom vorne *)	Moulding finisher MGB-GT front *)	1/1
S2MGB/GT	Dachleiste MGB-GT chrom hinten *)	Moulding finisher MGB-GT rear *)	1/1
S4MGB/GT	Zierleiste Türkante MGB-GT *)	Finisher door waist MGB-GT *)	1/1
S5MGB/GT	Abschlußleiste B-Säule MGB-GT bis 72 *)	Finisher cap b-post MGB-GT up to 72 *)	1/1
S5AMGB/GT	Abschlußleiste B-Säule MGB-GT ab 72 *)	Finisher cap b-post MGB-GT from 72 *)	1/1
S6MGB/GT	Zierleiste an Ausstellfenster *)	Finisher quarter light *)	1/1
R9MGB/GT	Frontscheiben-Gummi	Frontscreen rubber	1
R10MGB/GT	Füllstreifen	Filler strip	1
R11MGB/GT	Zierleiste Frontscheibe oben	Finisher frontscreen trim upper	1
R12MGB/GT	Zierleiste Frontscheibe unten	Finisher frontscreen bottom	1
R13MGB/GT	Zierleiste Frontscheibe *)	Finisher frontscreen *)	1/1
R14MGB/GT	Zierstreifen-Ecke unten	Corner finisher lower	2
R15MGB/GT	Zierstreifen-Ecke oben	Finisher corner upper	2
R16AMGB/GT	Heckscheibe heizbar	Rear screen heated	1
R16BMGB/GT	Heckscheibe heizbar, getönt	Rear screen heated, tinted	1
R17MGB/GT	Heckscheiben-Gummi	Backlight glazing rubber	1
R19MGB/GT	Zierleiste Heckscheibe *)	Backlight finisher *)	1/1
R20MGB-20	Klammer Zierleiste MGB-GT	Clip moulding finisher MGB-GT	2
R20MGB-30	Clip Zierleiste	Backlight finisher clip	2
R23MGB/GT	Gummi-Dichtung Ausstellfenster	Rubber seal quarter light	2
R24MGB/GT	Glas Ausstellfenster hinten *)	Glass quarter light rear *)	1/1
R25MGB/GT	Dichtung Ausstellfenster (schwarz) hinten *)	Seal quarter light (black) rear *)	1/1
R61MGB/GT	Zierleisten-Satz Frontscheibe (8 tlg - beinhaltet R11,12,13,14+15MGB)	Frontscreen moulding set (8 pcs - contains R11,12,13,14+15MGB)	1

alle Modelle		all models	
S8MGB	Zierleiste Kotflügel MGB vorne *)	Finisher wing MGB front *)	1/1
S8MGB-SET	Satz Zierleisten, 6 Teile (S8+S9+S10MGB x 2)	Finisher kit 6 pieces (S8+S9+S10MGB x 2)	1
S9MGB	Zierleiste Türe MGB *)	Finisher door MGB *)	1/1
S10MGB	Zierleiste Kotflügel MGB hinten *)	Finisher rear wing MGB *)	1/1
S11MGB	Zierleisten-Schraube	Stud plate finisher	6
S12MGB	Zierleisten-Nieten MGB	Wing finisher clip MGB	ca. 50
S13MGB	Stange Innenspiegel chrom	Centre rod, chrome	1
S15MGB	Innenspiegel bis '70	Interior mirror up to 70	1
S16MGB	Innenspiegel abblendbar ab '70	Interior mirror dipping from 70 on	1
i117	Mutter UNF 3/16 x 1/8"	Nut UNF 3/16 x 1/8"	6

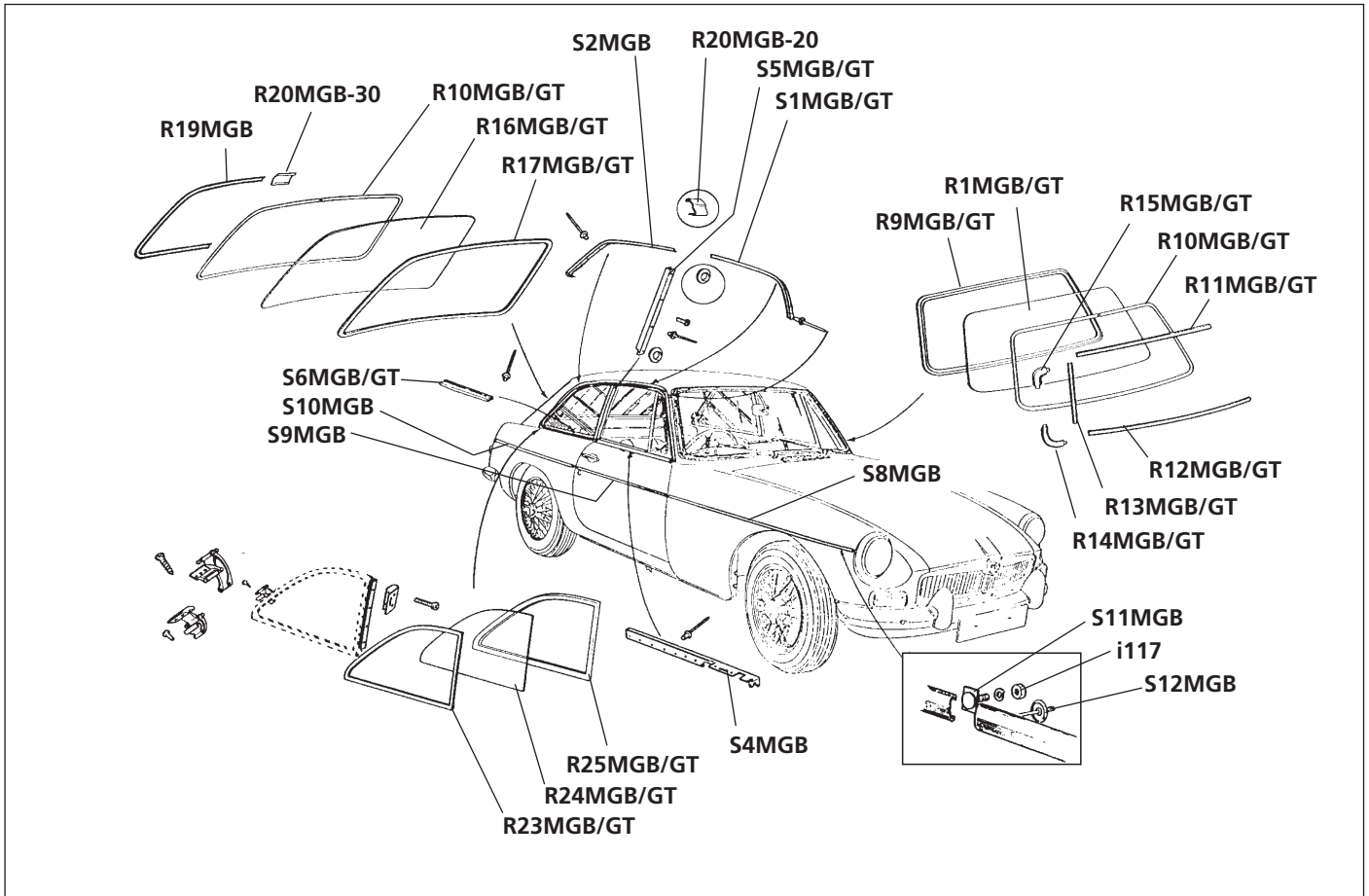
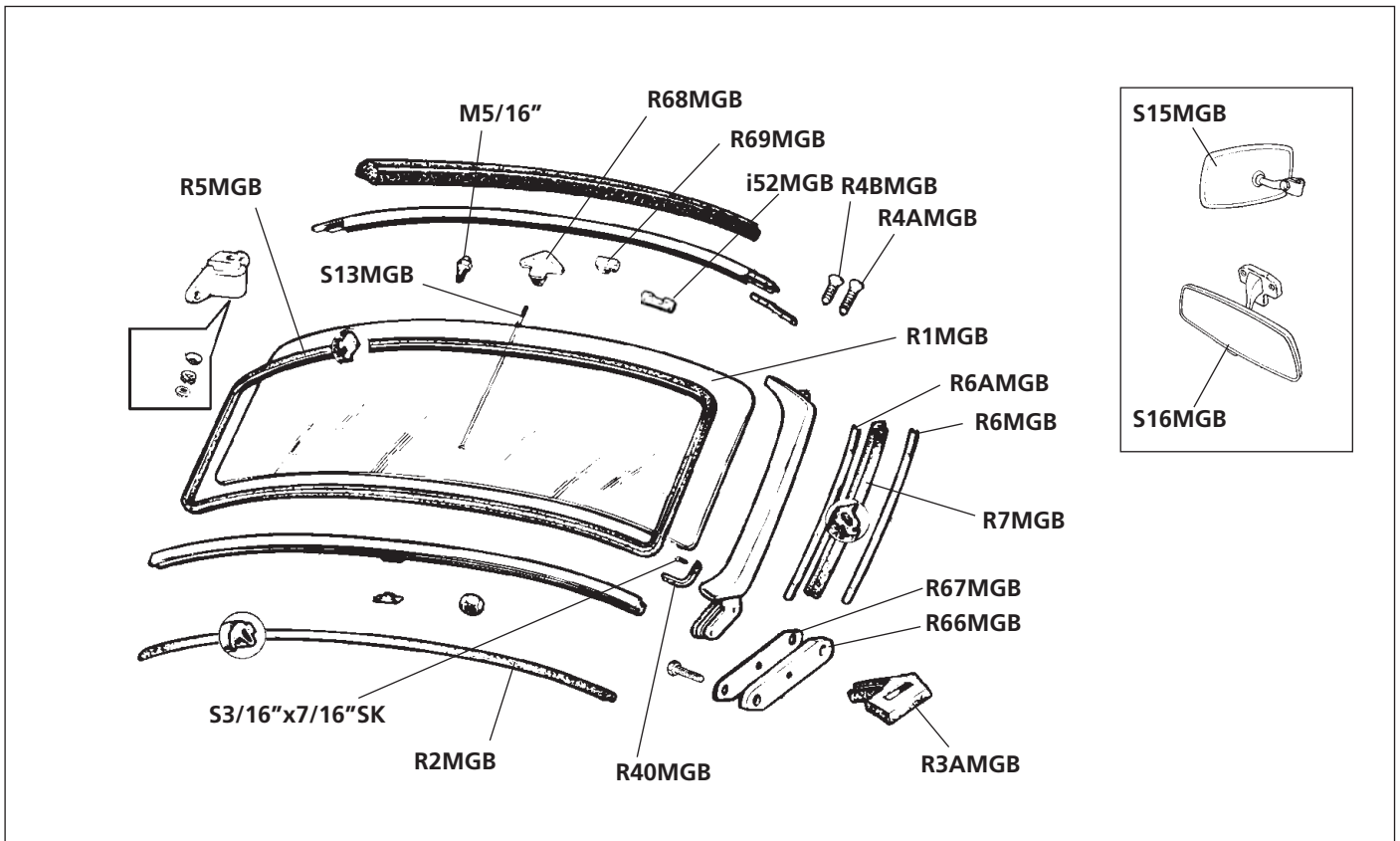

*) Bitte Seite angeben

*) Please refer side

Roadster		Roadster	
No.	Bezeichnung	Description	Anzahl/Qty.
R26AMGB	Ausstellfenster *)	Quarter light *)	1/1
R28MGB	Scharnier oben *)	Top pivot *)	1/1
R29MGB	Scharnier unten *)	Pivot lower *)	1/1
R30MGB	Gummi-Dichtung Ausstellfenster *)	Rubber seal quarter light *)	1/1
R31MGB	Glas Ausstellfenster *)	Glass quarter light *)	1/1
R32MGB	Haltestift unten	Bottom pivot	2
R32AMGB	Distanzstück vorne	Reinforcement front	2
R33MGB	Feder	Spring	2
R37MGB	Gummi-Dichtung Ausstellfenster *)	Rubber seal quarter light *)	1/1
R50MGB	Türscheibe *)	Door glass *)	1/1
R67MGB	Abflußkanal *)	Drain channel *)	1/1
R74MGB	Verschlusskappe	Capping	2

GT		GT	
R28MGB/GT	Scharnier oben *)	Top pivot *)	1/1
R29MGB/GT	Scharnier unten *)	Pivot lower *)	1/1
R32AMGB	Distanzstück vorne	Reinforcement front	2
R33MGB	Feder	Spring	2
R42MGB/GT	Gummi-Dichtung Ausstellfenster *)	Rubber seal quarter light *)	1/1
R44MGB/GT	Haltestift unten für abgerundeten Verschlusshebel	Pin bottom pivot, curved handle	2
R44AMGB/GT	Haltestift unten für geraden Verschlusshebel	Pin bottom pivot, flat handle	2
R49MGB/GT	Gummi-Dichtung Ausstellfenster unten	Rubber seal quarter light lower	2
R51MGB/GT	Türscheibe *)	Door glass *)	1/1
M1/4"S	Mutter Nylon	Nut nyloc	A/R

alle Modelle		all models	
S13MGA-38	Verschlusshebel Ausstellfenster abgerundet rechts	Handle quarterlight locking curved rh	1
S14MGA-38	Verschlusshebel Ausstellfenster abgerundet links	Handle quarterlight locking curved lh	1
S15MGB	Verschlusshebel Ausstellfenster gerade Form 4-Synchro *)	Handle quarterlight locking flat 4-synchro *)	1/1
R34MGB	Bügel für abgerundeten Verschlusshebel	Bracket quarter light handle curved	2
R34AMGB	Bügel für flachen Verschlusshebel	Bracket quarter light handle flat	2
R39AMGB	Gummiecke Ausstellfenster bis 1969 mit Chromrahmen	Corner block to 1969 chrome frame	2
R39BMGB	Gummiecke Ausstellfenster bis 1969-73 mit Chromrahmen	Corner block 1969-73 chrome frame	2
R39CMGB	Gummiecke Ausstellfenster ab 1973 mit Edelstahlrahmen	Corner block 1973 on stainless frame	2
R52MGB	Gummi-Fensterführung	Flexible window channel	2
R53MGB	Fensterführung hinten *)	Channel window rear *)	1/1
S54MGB	Fensterkurbel +Chromknopf bis 68, 3-Synchro	Window regulator handle up to 68, 3-synchro	2
S55MGB	Fensterkurbel Hexagon ab 68, 4-Synchro	Window handle hexagon from 68, 4-synchro	2
S56MGB	Scheibe hinter Fensterkurbel	Washer behind window handle	2
S57MGB	Unterlage Fensterkurbel chrom	Bezel window winder chrome	2
S57BMGB	Schraube Fensterkurbel	Spacer +screw	2
R58MGB	Regenabstreifleiste *)	Top door rubber *)	1/1
R59MGB	Filzdichtleiste Türe innen *)	Felt weatherstrip inner *)	1/1
R60MGB	Haltebügel für Fensterführung vorne + hinten 2-Schrauben- Befestigung *)	Bracket glass front + rear channel 2 screw fitting*)	1/1
R71MGB	Fensterführung vorne	Channel front flexible	2
R72MGB	Fensterheber bis GHN3-57985 *)	Regulator up to GHN3-57985 *)	1/1
R72AMGB	Fensterheber ab GHN/GHD4+5 -57986 *)	Regulator from GHN/GHD4+5 -57986 *)	1/1
R73MGB	Schiene Seitenscheibe unten	Channel, lower	2
R75MGB	Gummidichtung Ausstellfenster	Rubber glazing	2

*) Bitte Seite angeben

*) Please refer side

Roadster

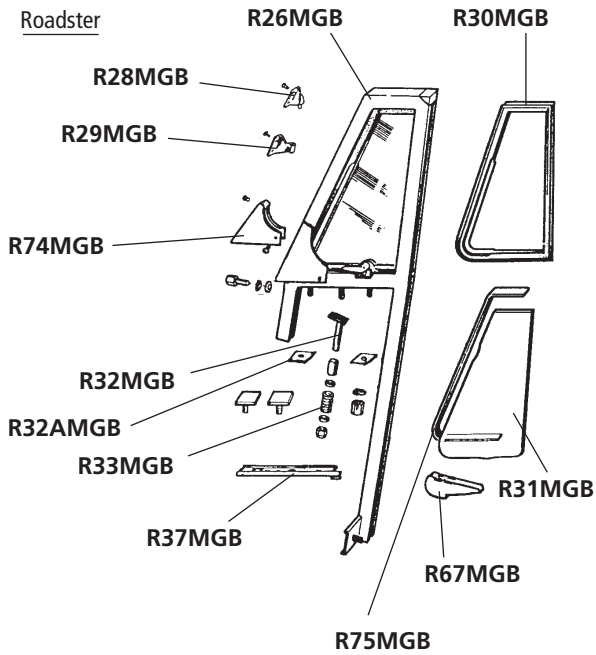

GT

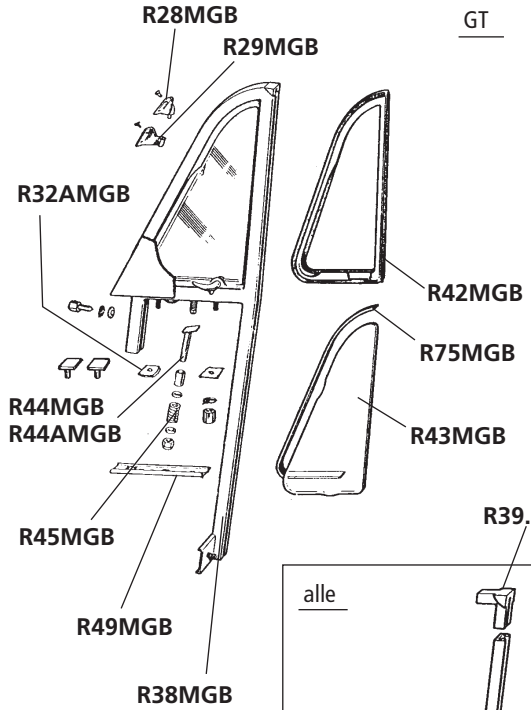

R50MGB

R51MGB

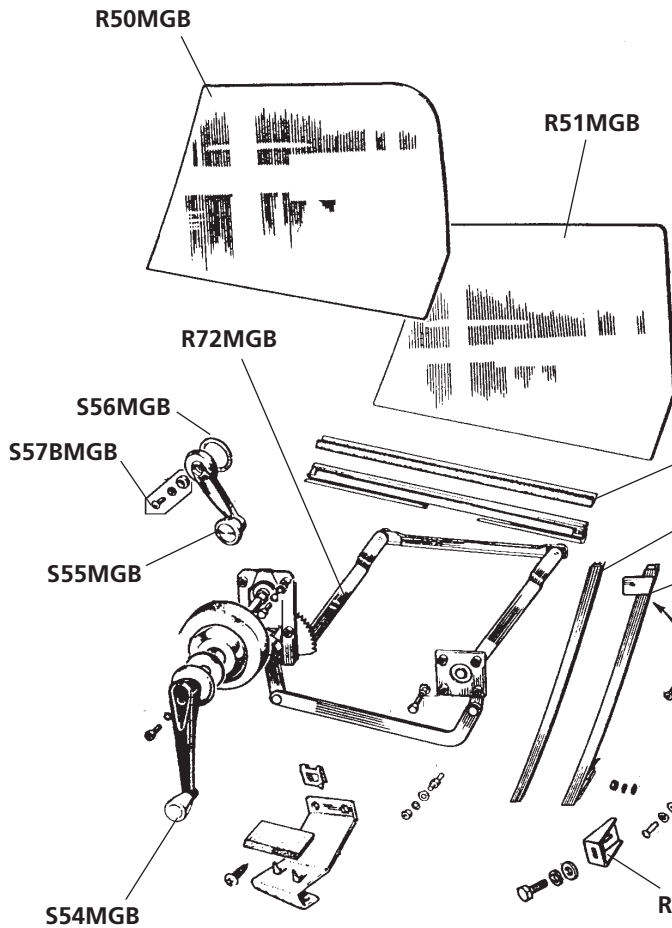

S13MGA-38

S14MGA-38

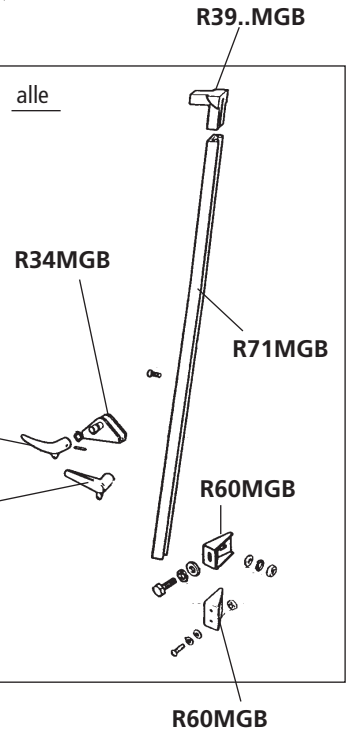

alle

R58MGB

R59MGB

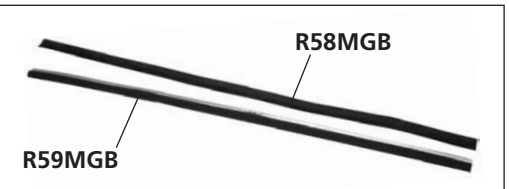

R60MGB

R60MGB

No.	Bezeichnung	Description	Anzahl/Qty.
S1SPTMK3	Türgriff aussen GHN3 57986 bis GHN4 138400 *)	Door handle exterior GHN3 57986 to GHN4 138400 *)	1/1
S1ASPTMK3	Paar Türschließzylinder ab 1965	Replacement lock set 1965 on	1
S1BSPTMK3	Türgriffunterlagen Satz	Gasket kit handle door	1
S5TR6	Türzuzieher chrom	Handle interior chrom	2
S8SPTMK3	Lucas-Style Spiegel *)	Lucas-style mirror *)	1/1
S8C	Talbot-Style Spiegel	Talbot-style torpedo mirror	2
S8SPTMK4	Außenspiegel eckig, chrom *)	Mirror rectangle, chrome *)	1/1
SR8	Senkkopfschraube	Countersunk screw	A/R
SR9	Senkkopfschraube Scharnier an Tür	Countersunk screw hinge to door	A/R
S10SPTMK4	Türfangplatte Roadster ab GHN/D4 138401, GT ab GHN/D4 138401 *)	Door striker dovetail Roadster from GHN/D4 138401, GT from GHN/D4 138401 *)	1/1
S10ASPTMK4	Unterlage Türfangplatte	Gasket door striker dovetail	2
S21MGB-27	Türöffner innen früh bis 68	Door handle interior early up to 68	2
S21AMGB-27	Türöffner innen spät ab 68 *)	Door handle interior late from 68 *)	1/1
S22MGB-27	Umrandung Türöffner innen ab 68	Finisher chrome door handle from 68	2
S25MGB-27	Türschloß innen ab GHN/D4 138401 *)	Door lock interior from GHN/D4 138401 *)	1/1
S26MGB-27	Türschloß innen ab GHN/D3 57986 bis GHN4 138400 *)	Door lock interior from GHN/D3 57986 to GHN4 138400 *)	1/1
S26AMGB-27	Schlossfalle B-Säule Roadster *)	Door striker B-post Roadster *)	1/1
S26BMGB-27	Schlossfalle B-Säule GT *)	Door striker B-post GT*)	1/1
S27MGB-27	Türschloß innen Roadster bis GHN3 57985 *)	Door lock interior Roadster up to GHN3 57985 *)	1/1
S27AMGB-27	Schloßfalle B-Säule Roadster bis GHN3 57985	Door striker B-post Roadster up to GHN3 57985	2
KA27MGB-27	Türscharnier oben *)	Door hinge upper *)	1/1
KA27AMGB-27	Türscharnier unten *)	Door hinge lower *)	1/1
S29MGB-27	Türgriff aussen früh bis GHN3 57985 *)	Door handle exterior early up to GHN3 57985 *)	1/1
S29BMGB-27	Türgriff aussen ab GHN4 138401	Door handle exterior from GHN4 138401	2
S32AMGB-27	Türgriff innen schwarz ab 72	Door pull handle black from 74	2
S32BMGB-27	Türgriff innen /Armlehne ab 74	Door pull handle/armrest black from 74	2
S33MGB-27	Knopf Türverriegelung	Knob locking	2
S34MGB-27	Zierleiste Türschloß innen	Finisher door lock interior	2
S35MGB-27	Chromkappe für Dichtung hinten *)	Chrome finisher rear for seal *)	1/1
S36MGB-27	Chromkappe für Dichtung vorne *)	Chrome finisher front for seal *)	1/1
S37MGB-27	Zierdeckel an Türverschuß GT *)	Door shut finisher GT *)	1/1
S38MGB-27	Zierblende Schweller Edelstahl	Threshold plate sill stainless steel	2
S38AMGB-27	Zierblende Schweller mit MG-Logo	Threshold plate sill with MG logo	2
S51MGA-03	Anschlaggummi Tür	Buffer door	2
i40MGA-40	Türdichtung Gummi/Velours schwarz Roadster	Draught excluder furflex black Roadster	A/R
R55AMGB-30	Türdichtung Gummi/Nylon schwarz Roadster	Draught excluder plastic black Roadster	A/R
R70MGB-30	Türdichtung Gummi/Velours schwarz GT	Draught excluder MGB-GT furflex black GT	A/R
R71MGB-30	Türdichtung Gummi/Nylon schwarz GT	Draught excluder MGB-GT plastic black GT	A/R
R72MGB-27	Anschlaggummi Scharnier	Buffer, hinge	2

*) Bitte Seite angeben

*) Please refer side



Type 1: nur Roadster bis '65 / only Roadster to '65 bis/to GHN3 57985

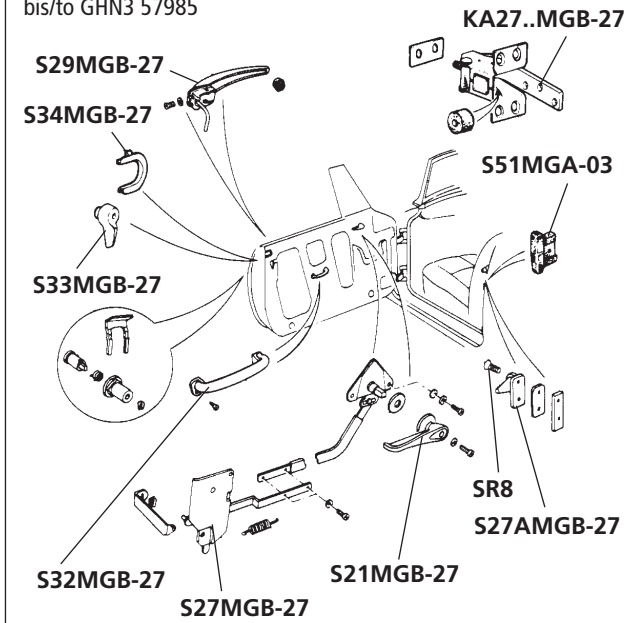

Type 2: Roadster & GT '65-67
GHN/D3 57986 - GHN4 138400, GHD 138400

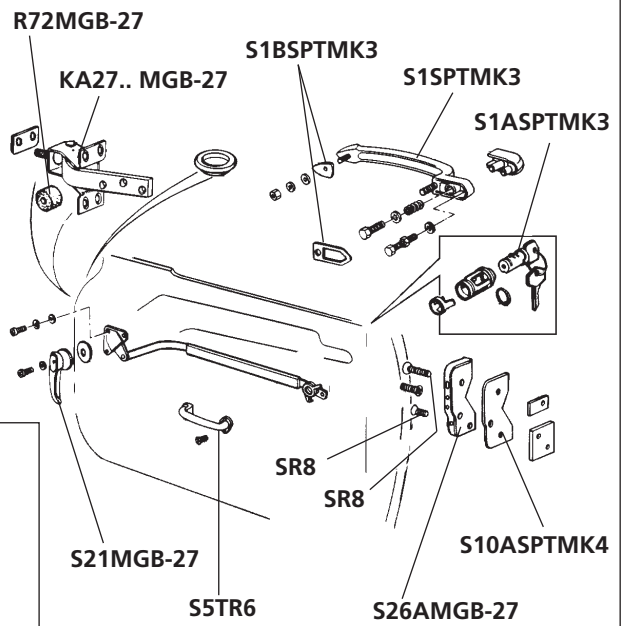

Type 3: Roadster & GT ab/from '68
ab GHN/D4 138401 on

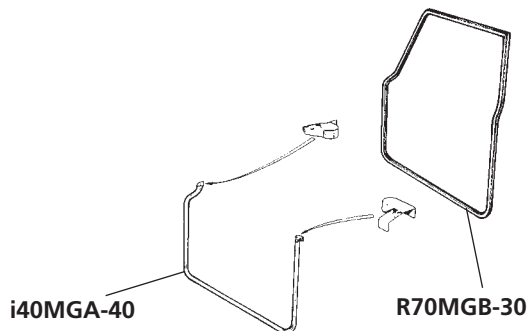
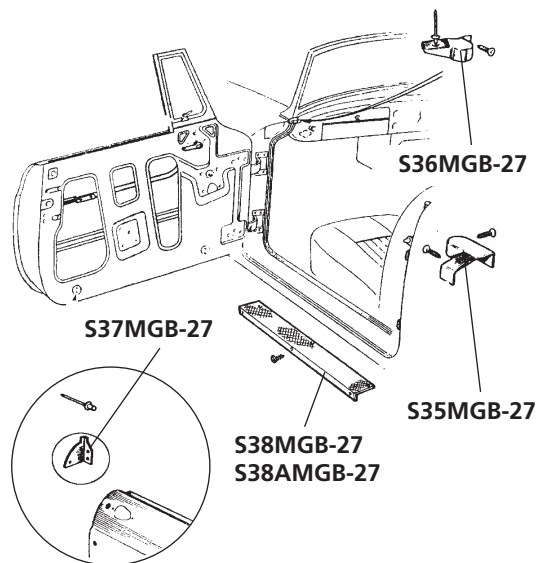
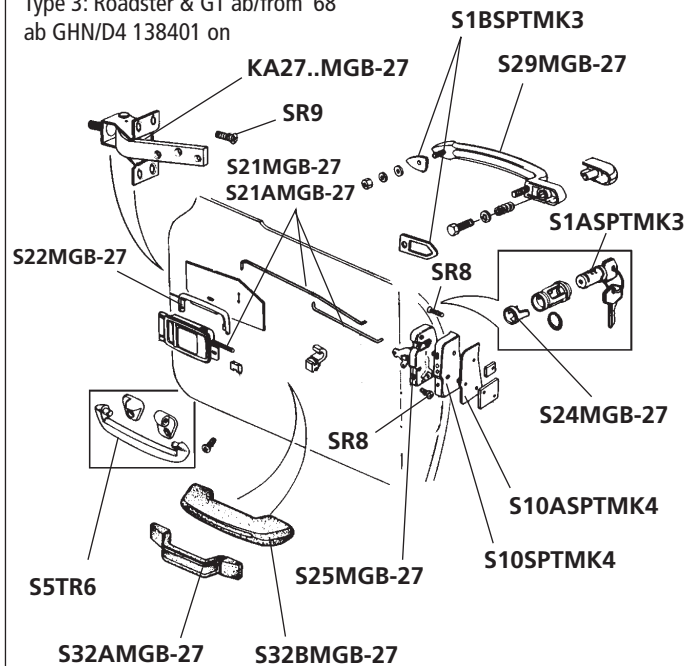

No.	Bezeichnung	Description	Anzahl/Qty.
EM1ATR	Klammer für EM34..MGB-32	Fitting clip to no. EM34..MGB-32	3
S24MGB-32	Luftführung unter Kühler Gummistoßst.modell	Air duct panel rubber bumper model	1
S25MGB-31	Schutzkarton unter Riemenscheibe ab 77	Mudshield from 77	1
EM34MGB-32	MG-Abzeichen auf Gummi-Stosstange silber	MG-Emblem front rubber bumper silver	1
EM34AMGB-32	MG-Abzeichen auf Gummi-Stosstange gold	MG-Emblem front rubber bumper gold	1
EM34BMGB-32	MG-Abzeichen auf Gummi-Stosstange rot	MG-Emblem front rubber bumper red	1
S36MGB-32	Kühlergrill-Gitter Gummistoßstangenmodell ab 75	Air intake grille Rubber bumper model from 75	1
S37MGB-32	Kühlergrill chrom 62-69	Radiator grille 62-69	1
S38MGB-32	Kühlergrill chrom mit schwarzem Gitter 72-74	Radiator grille 72-74	1
S39MGB-32	Kühlergrill 69-72	Radiator grille 69-72	1
S40MGB-32	Zierblech unten zu Kühlergrill S39MGB-32	Finisher radiator grille lower to no S39MGB-32	1
S41MGB-32	Zierblech Kühlergrill rechte Seite zu S39MGB-32	Grille finisher side rh to no S39MGB-32	1
S41AMGB-32	Zierblech Kühlergrill linke Seite zu S39MGB-32	Grille finisher side lh to no S39MGB-32	1
S42MGB-32	Zierleiste Kühlergrill oben zu S39MGB-32	Finisher radiator grille upper to no S39MGB-32	1
S43MGB-32	Zierleiste Kühlergrill unten zu S39MGB-32	Finisher radiator grille lower to no S39MGB-32	1
S44MGB-32	Klammer zu Zierleisten Kühlergrill S41-44MGB-32	Clip radiator grille finisher to no S41-44MGB-32	12
S45MGB-32	Zierleiste Motorhaube	Finisher bonnet MGB	1
EM46MGB-32	MG-Abzeichen Kühlergrill zu S39MGB-32	MG-medailon grille to no S39MGB-32	1
EM47MGB-32	Halter MG-Zeichen zu S46MGB-32	Plinth frontal MG-emblem to no S46MGB-32	1
EM47AMGB-32	Clip zu Halter MG-Zeichen	Clip to plinth MG-emblem	1
EM48MGB-32	MG-Abzeichen Kühlergrill schwarz 63-68	MG-medailon grille black 63-68	1
EM49MGB-32	MG-Abzeichen Kühlergrill rot 72-75	MG-medailon grille red 72-75	1
S50MGB-32	Kühlerhalteblech Satz 3-teilig	Grill stay set (3 pieces)	1

Embleme s. auch Seite 133

more badges - please refer page 133

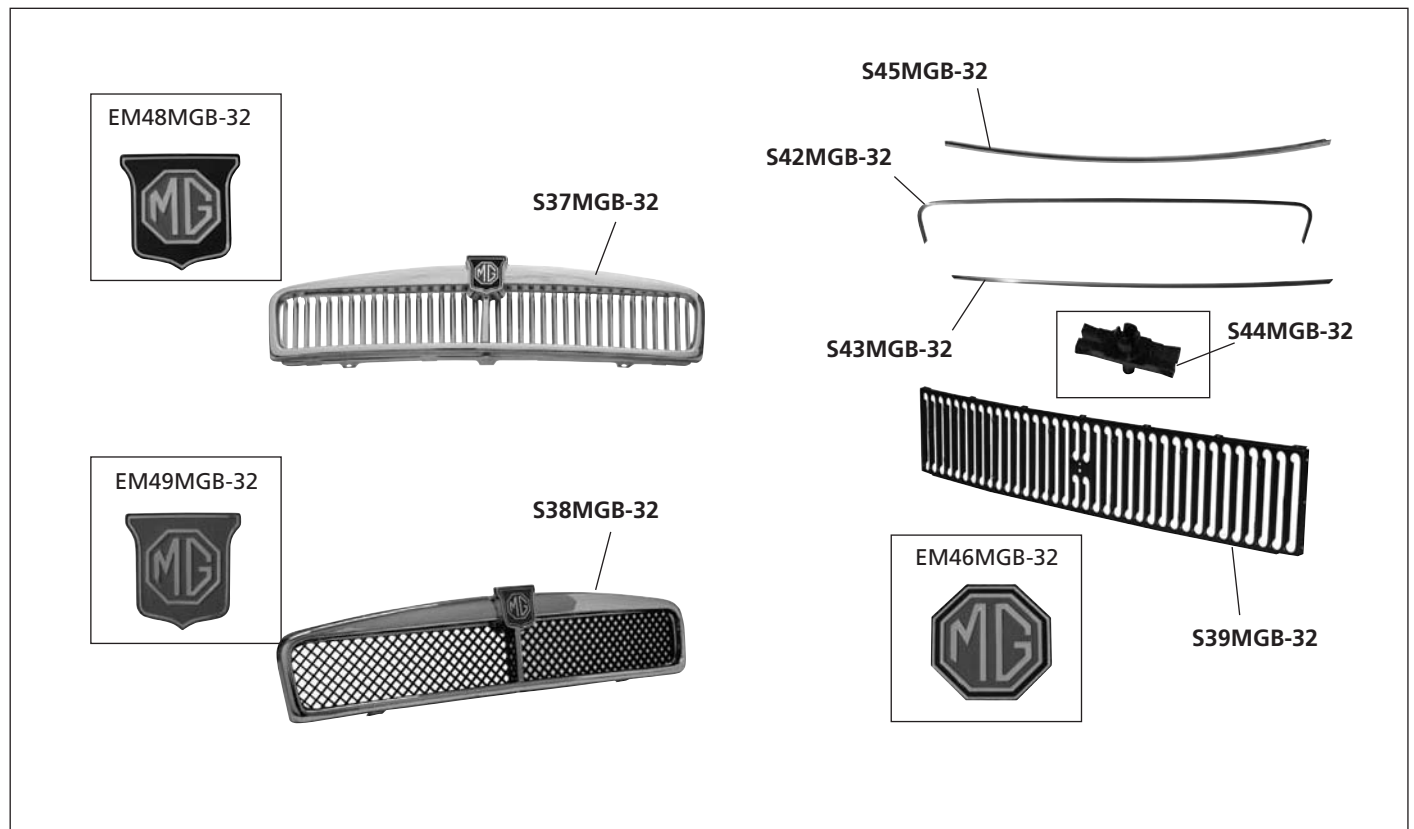

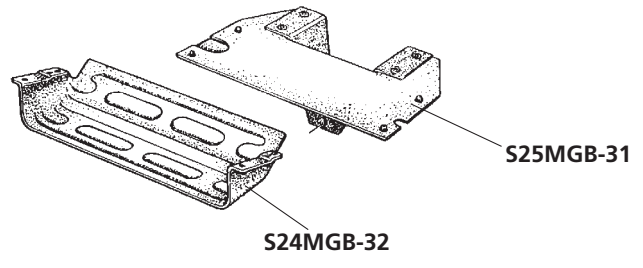
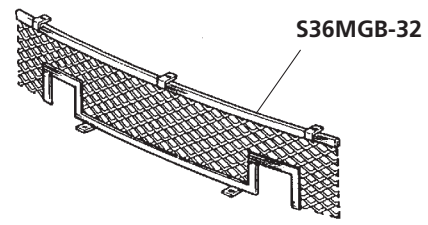
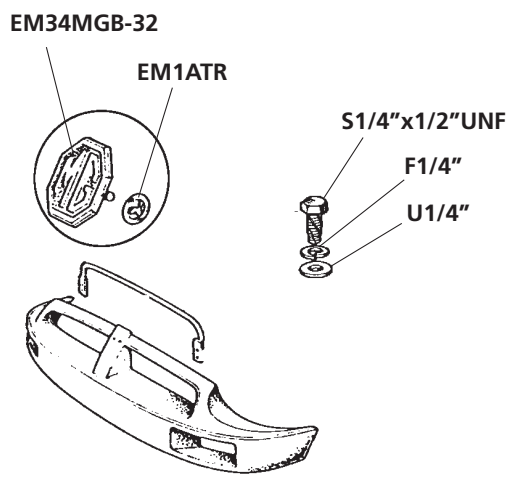
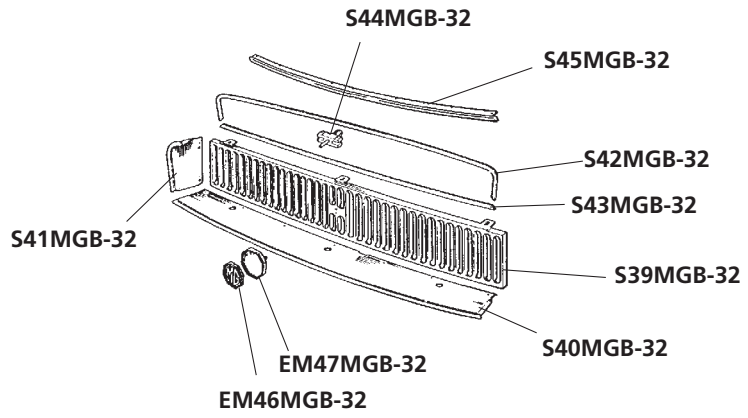
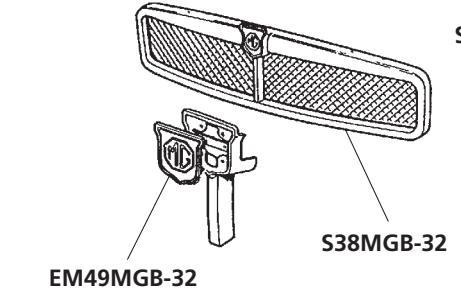
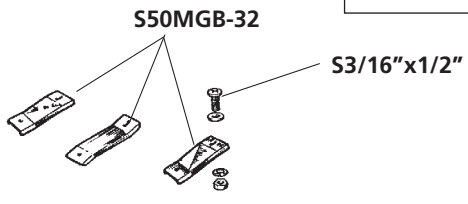
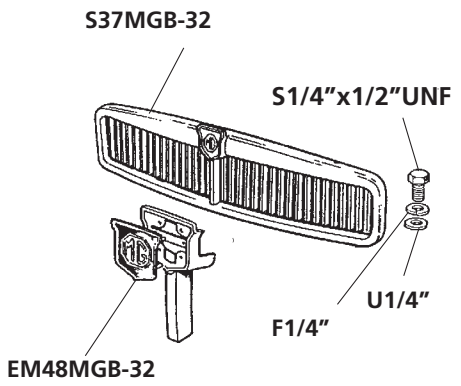

No.	Bezeichnung	Description	Anzahl/Qty.
S01MGB-31	Stoßstange chrom vorne	Bumper chrome front	1
S01BMGB-31	Stoßstange Befestigungsschrauben-Satz vorne	Bumper fitting kit front	1
S02MGB-31	Stoßstange Träger bis 75 vorne *)	Bumper spring bar up to 75 front *)	1/1
S04MGB-31	Stoßstange Haltewinkel vorne außen	Steady bracket outer front bumper	2
S05MGB-31	Gummi-Puffer	Bumper rubber	2
S06MGB-31	Distanz-Scheibe Stoßstange	Spacer washer bumper	6
S08MGB-31	Stoßstange-Horn chrom früh vorn	Override chrome early front	2
S09MGB-31	Stoßstange-Horn chrom mit Gummipuffer vorne	Override chrome +buffer front	2
S12MGB-31	Stoßstange chrom hinten	Bumper rear chrome	1
S13MGB-31	Stoßstange Träger bis 75 hinten	Bumper iron up to 75 rear	2
S14MGB-31	Stoßstange Befestigungsschrauben-Satz hinten	Bumper fitting kit rear	1
S14AMGB-31	Stoßstange-Haltebügel hinten	Bumper mounting bracket rear	2
S15MGA-01	Nummernschild-Träger vorne, alle Modelle	Number plate carrier front, all models	1
S15AMGA-01	Nummernschild-Träger vorne Edelstahl, alle Modelle	Number plate carrier front stainl. steel, all models	1
S17MGB-31	Unterlage Stoßstange rechts Edelstahl	Bumper filler rh stainless steel	1
S17AMGB-31	Unterlage Stoßstange links Edelstahl	Bumper filler lh stainless steel	1
S18MGB-31	Stoßstangen-Horn chrom hinten re mit Bohrung für Lampe	Override chrome/lamp holes rear rh	1
S18AMGB-31	Stoßstangen-Horn chrom hinten li mit Bohrung für Lampe	Override chrome/lamp holes rear lh	1
S19MGB-31	Stoßstange-Horn chrom mit Gummipuffer hinten rechts mit Bohrung	Rear override chrome rh with rubber + hole	1
S19AMGB-31	Stoßstange-Horn chrom +mit Gummipuffer hinten links mit Bohrung	Rear override chrome lh with rubber + hole	1
S21MGB-31	Bügel Nummernschild-Träger (Gummistoßstangen-Modell)	Bracket number plate carrier (Rubber bumper model)	2
S21AMGB-31	Bügel Nummernschild-Träger (Chromstoßstangen-Modell)	Bracket number plate carrier (Chrome bumper model)	1
S22MGB-31	Nummernschild-Träger hinten Edelstahl (Chromstoßstangen-Modell), Leuchte in Stoßstangenhorn	Number plate carrier rear stainl. steel (Chrome bumper model) with lights in override	1
S22EMGB-31	Nummernschild-Träger hinten Edelst. (Gummistoßstangenmodell)	Number plate carrier rear stainl. steel (Rubber bumper model)	1
S23MGB-31	Gummi-Puffer	Rubber buffer	2
S24MGB-31	Befestigungsblech auf Stoßstangenträger	Fixing plate an bumper beam	1
S26MGB-31	Gummi-Stoßstange vorne	Rubber skin bumper front	1
S27MGB-31	Stoßstangen-Träger vorne *)	Bumper support front *)	1/1
S28MGB-31	Träger Gummistoßstange	Bracket rubber bumper front	1
S29MGB-31	Stoßstangen-Gummihaut hinten	Bumper skin rubber rear	1
S30MGB-31	Träger für Gummiboot-Stoßstange	Side fixing bracket	1
S31MGB-31	Stoßstangen-Halterung seitlich	Armature, skin - rubber bumper models	2
S31AMGB-31	Befestigungsbolzen	Stud	5
S32MGB-31	Distanz-Scheibe Gummi-Stoßstange	Distance piece rubber bumper	4
S33MGB-31	Abzeichen-Stange (Chromstoßstangen-Modell) Befestigung an Nummernschild-Verschraubung	Badge bar (Chrome bumper model) to be mounted on number plate fixation	1
S33AMGB-31	Abzeichen-Stange (Chromstoßstangen-Modell) Befestigung an Stoßstangenhörner	Badge bar (Chrome bumper model) to be mounted on override	1
S33BMGB-31	Abzeichen-Stange (Chromstoßstangen-Modell)	Badge bar (Chrome bumper model)	1
S33CMGB-31	Abzeichen-Stange (Gummistoßstangen-Modell)	Badge bar (Rubber bumper model)	1
S33DMGB-31	Befestigungsclip Abzeichen	Retainer	1
S34MGB-31	Verstärkungsrahmen	Support, bumper	1
S35MGB-31	Bleckecke unterhalb Rückleuchte (erforderlich beim Umbau von Gummistoßstange auf Chromstoßstange)	Corner wing near taillight (necess. to rebuild rubber bumper to chrome bumper)	2
S36MGB-31	Umbau-Satz von Gummi- auf Chromstoßstange (ohne Grill)	Conversion kit rubber to chrome bumper (grille not included)	1
S37MGB-31	Paar Halteleisten zur Stoßstange	Pair retaining ledge to bumper	1
S54	Stoßstange-Schraube + Mutter lang	Bumper bolt + nut long	4/6
S55SPT	Gummi-Dichtung Stoßstange/Horn	Rubber moulding strip bumper/override	4

*) Bitte Seite angeben

*) Please refer side

Embleme s. auch Seite 133

more badges - please refer page 133

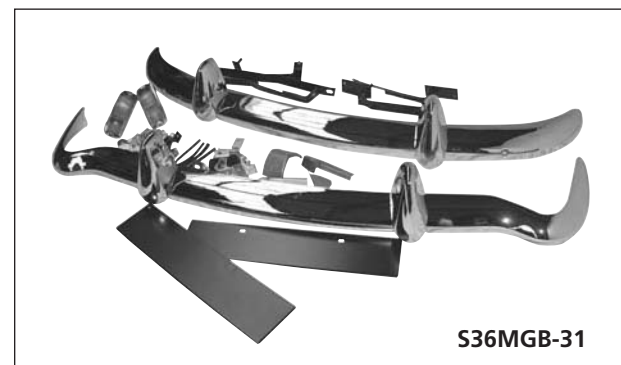
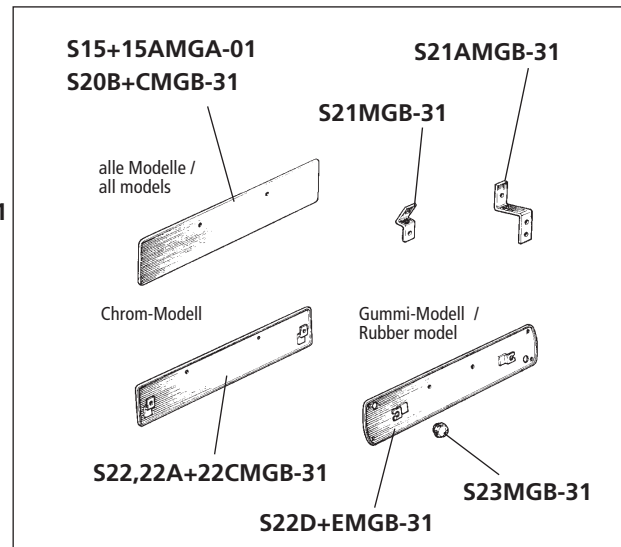
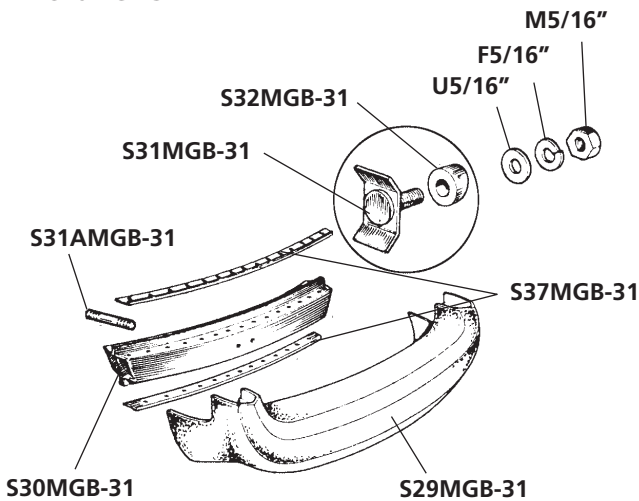
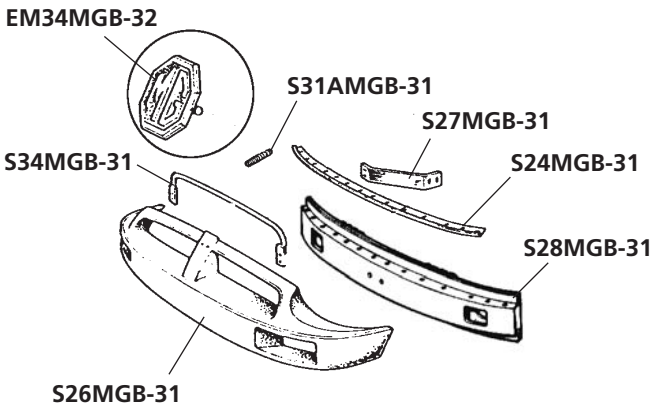
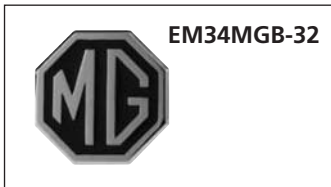
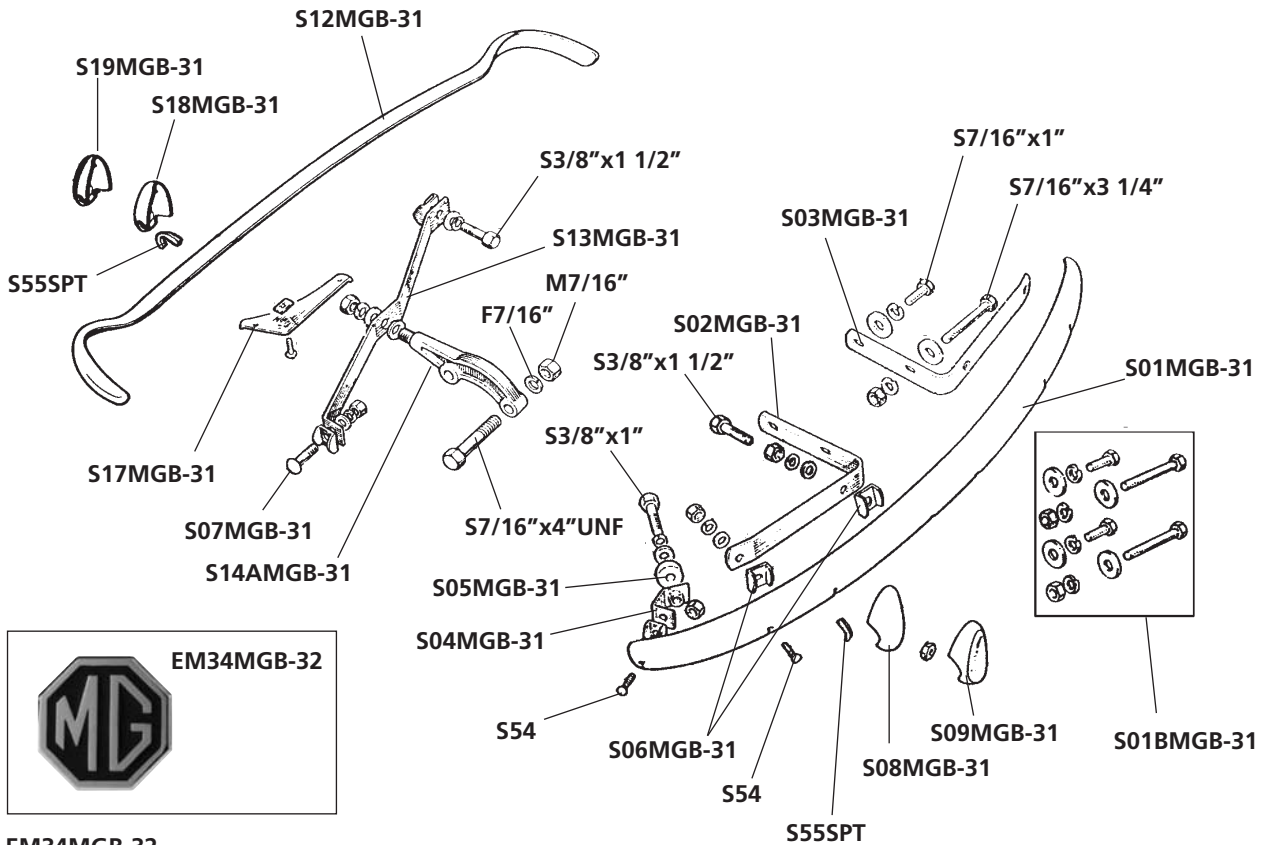

No.	Bezeichnung	Description	Anzahl/Qty.
EM1ATR	Halteclip für EM28+28AMGB-32	Fitting clip to no. EM28+28AMGB-32	3
EM28MGB-32	Emblem Kofferraumdeckel/Heckklappe Plastik	Emblem boot lid plastic	1
EM28AMGB-32	Emblem Kofferraumdeckel/Heckklappe MG Metall	Emblem boot lid metal	1
EM28BMGB-32	Emblem Kofferraumdeckel/Heckklappe Gold	Emblem boot lid Gold	1
S35MGB-29	Kofferraum-Schloss Unterteil	Boot lid lock lower	1
S36MGB-29	Bügel	Striker	1
S37MGB-29	Kofferraum-Schloss	Boot lid lock	1
S38MGB-29	Dichtring Kofferraumschloss MG	Sealing washer boot lid lock MG	1
EM44MGA-03	Emblem MG-Octagon (3 teilig)	Emblem MG + octagon surround (3 pcs)	1
EM45MGA-03	Klammer Abzeichen zu EM44MGA-03	Clip securing badge to EM44MGA-03	12/23

Roadster

Roadster

EM29MGB-32	Emblem MGB	Emblem MGB	1
S32MGB-29	Scharnier Kofferraum-Deckel rechts *)	Hinge boot lid *)	1
R33MGB-29	Gummi-Dichtung Kofferraum-Deckel	Rubber seal boot lid	1
R33AMGB-29	Gummi-Dichtung Kofferraum ab 76	Rubber seal boot lid from 76	1
S39MGB-29	Aufstellstange Kofferraum-Deckel bis GHN5 219000	Stay boot lid up to GHN5 219000	1
S39AMGB-29	Aufstellstange Kofferraum-Deckel ab GHN5 219001	Stay boot lid up from GHN5 219001	1
S60MGB	Gepäckträger Edelstahl	Luggage rack stainless steel	1
KA301MGB	Gasfeder-Kit Kofferraumdeckel, Roadster	Boot stay kit, Roadster	1

*) Bitte Seite angeben

*) Please refer side

Embleme s. auch Seite 133 more badges - please refer page 133

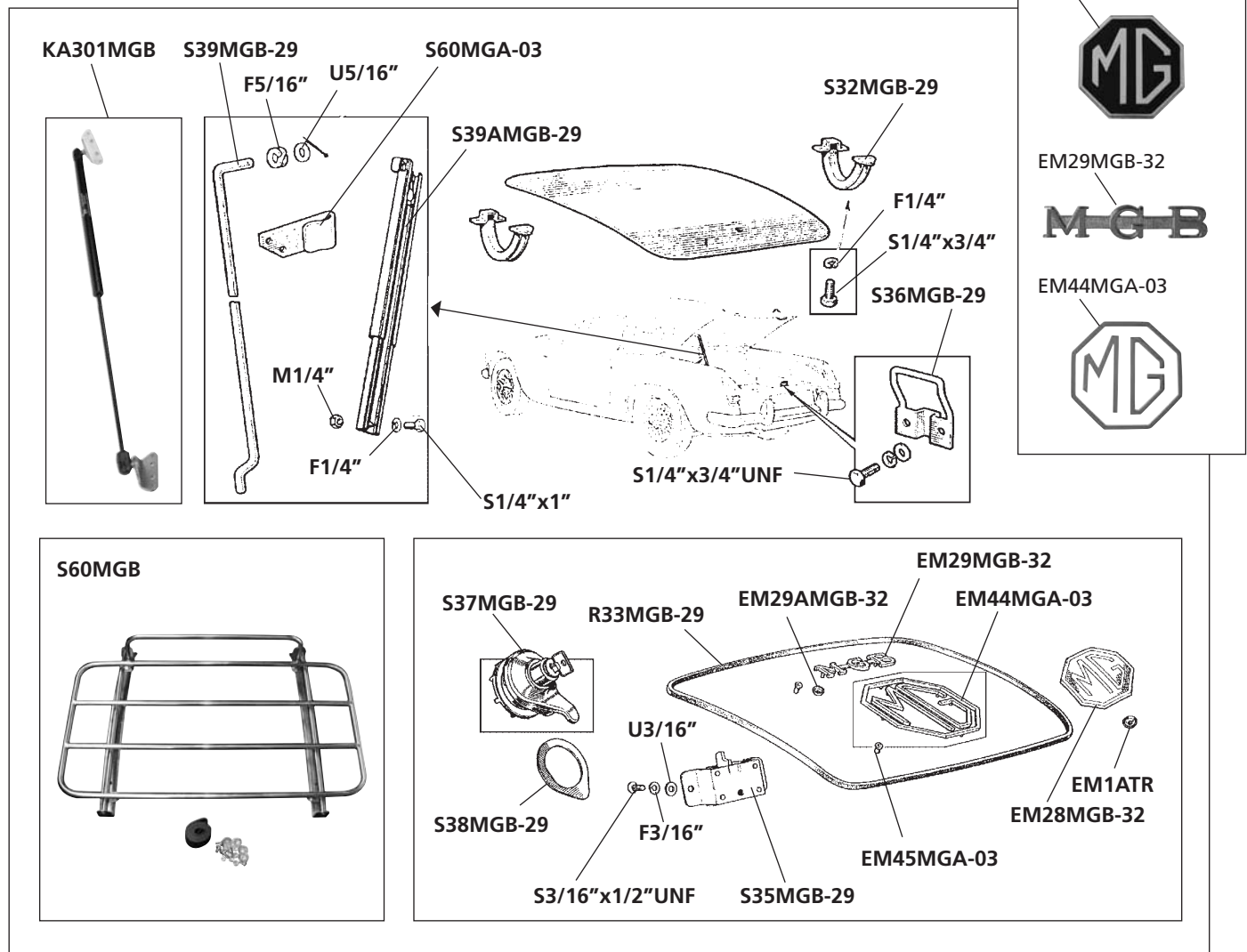

No.	Bezeichnung	Description	Anzahl/Qty.
EM1ATR	Halteclip Abzeichen	Retainer	3
S25MGB-29	Heckklappen-Scharnier *)	Tailgate hinge *)	1/1
S26MGB-29	Heckklappen-Ständer *)	Tailgate stay *)	1/1
S28MGB-29	Chrom-Deckel Heckklappenständer	Chrome cover tailgate stay	2
S28AMGB-29	Deckel Fettkappe klein	Cap cover small	2
S28BMGB-29	Deckel Fettkappe gross	Cap cover large	2
R29MGB-29	Gummi-Dichtung Heckklappe aussen	Rubber seal boot lid outer	1
R30MGB-29	Gummi-Dichtung Heckklappe innen	Rubber seal boot lid inner	1
EM30AMGB-32	Abzeichen MGB-GT schwarz/silber	Badge tailgate MGB-GT black/silver	1
EM30BMGB-32	Abzeichen MGB-GT schwarz/gold	Badge tailgate MGB-GT black/gold	1
EM30CMGB-32	Abzeichen MGB-GT blau/silber	Badge tailgate MGB-GT blue/silver	1
EM30DMGB-32	Abzeichen MGB-GT rot/silber	Badge tailgate MGB-GT red/silver	1
EM31MGB-32	Abzeichen B	Badge B	1
EM31AMGB-32	Klammer Plastik	Clip plastic	A/R
EM32MGB-32	Abzeichen GT	Badge GT	1
EM33MGB-32	Abzeichen MGB-GT	Badge MGB-GT	1
EM35SPT	Abzeichen Leyland am Kotflügel	Badge Leyland on wing	1
S35MGB-29	Kofferraumschloß Unterteil	Latch	1
S42MGB-29	Befestigungsbolzen zu S26MGB-29	Stud to no. S26MGB-29	2
EM54MGB-32	Abzeichen MGB-GT hinten auf C-Säule *)	Badge MGB-GT rear to C-post *)	1
i108TR	Chrom-Hutmutter zu S26MGB-29	Dome nut chrome to no. S26MGB-29	4
KA301MGB/GT	Gasfeder-Kit Heckklappe	Tailgate stay kit gas	1

*) Bitte Seite angeben

*) Please refer side

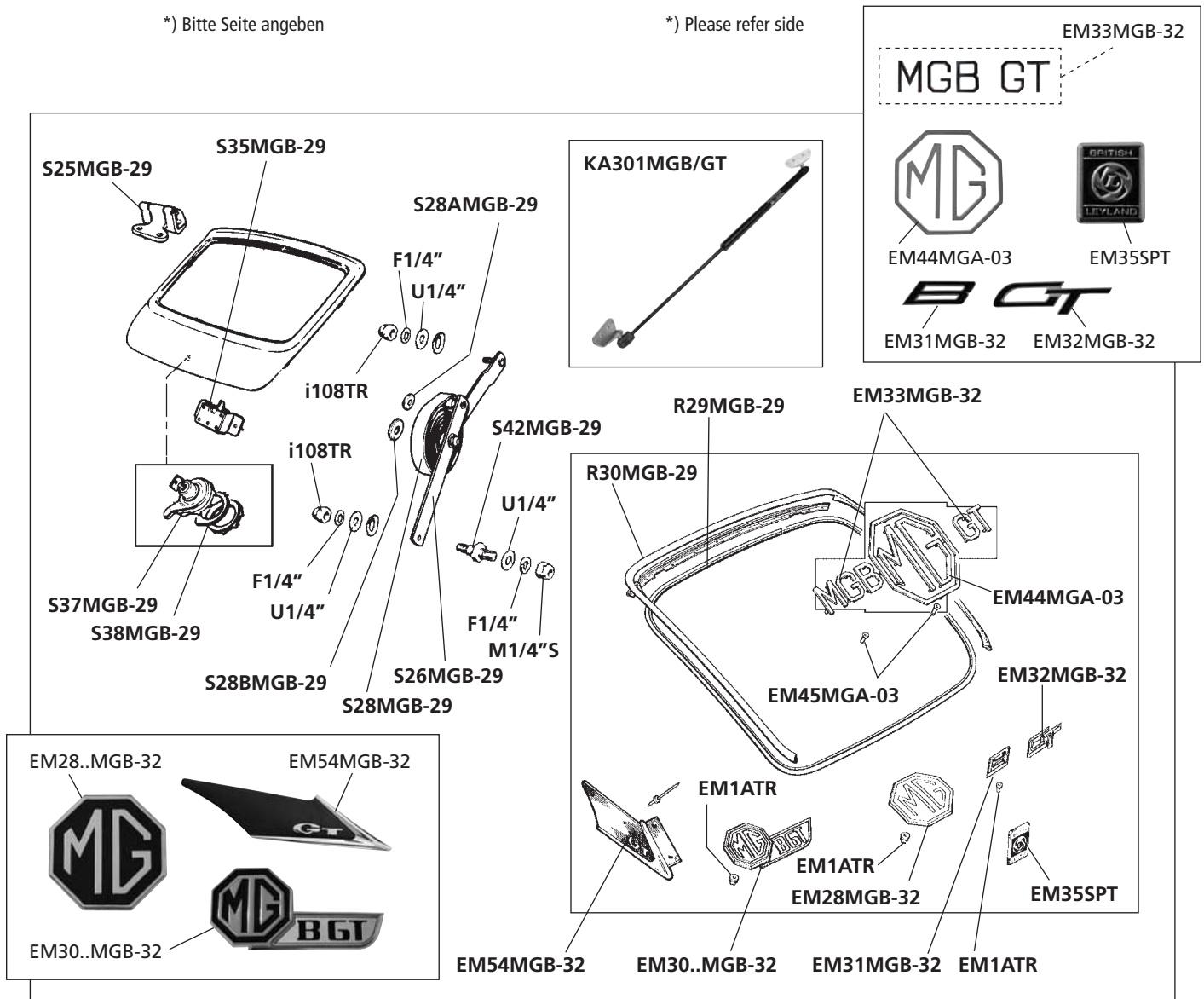

No.	Bezeichnung	Description	Anzahl/Qty.
i03AMGB-29	Motorhaube Isolierung Satz (2 Teile)	Bonnet insulating set (2 pieces)	1
S04MGB-29	Scharnier Motorhaube	Bonnet hinge	2
S05MGB-29	Motorhaube-Zug (Knebel-Griff)	Bonnet release cable t-handle	1
S06MGB-29	Endstück Zug	Trunnion control cable	1
S07MGB-29	Schraube	Screw	1
S08MGB-29	Gummi-Puffer Motorhaube	Rubber bonnet to side	2/4
S08AMGB-29	Rundkopf-Schraube UNF 3/16 x 3/8"	Screw rounded head UNF 3/16 x 3/8"	8
R09MGB-29	Gummi-Dichtung Motorhaube	Rubber seal bonnet	1
R10MGB-29	Klebedichtung Motorhaube hinten	Bonnet seal rear	1
R11MGB-29	Gummi-Dichtung Kühlerblech	Rubber seal radiator	1
S12MGB-29	Motorhaube-Aufsteller bis '71	Bonnet prop up to '71	1
S13MGB-29	Motorhaube-Aufsteller ab '71	Bonnet prop from '71	1
S15MGB-29	Halteblech Gummi	Bracket sealing rubber	1
S16MGB-29	Motorhaube-Sicherungsriegel	Safety catch bonnet	1
S17MGB-29	Bügel Sicherheitsriegel	Bracket safety catch	1
S17MGB-32	Chromgrill auf dem Lufteinlass	Air intake grille	1
S17AMGB-32	Chromnetz auf dem Lufteinlass	Mesh air intake grille	1
S18MGB-29	Schlossplatte (Chromstoßstangen-Modell)	Release catch plate (Chrome bumper model)	1
S19MGB-29	Führungstrichter	Locating cup	1
S20MGB-29	Sicherungsstift	Locking pin	1
S21MGB-29	Federtasse	Thimble	1
S22MGB-29	Haubenschlussfeder	Bonnet spring	1
S23MGB-29	Feder Schlossplatte	Spring catch plate	1
EM31AMGB-32	Befestigungsclip Chromgrill Lufteinlass	Bush friction	6
R41TR3	Gummi-Halter Aufstellstab Motorhaube	Rubber retainer bonnet prop	1
S44MGB-29	Rundkopf-Schraube UNF 3/16 x 1/2"	Screw rounded head UNF 3/16 x 1/2"	2
S45MGB-29	Klemmmutter zu S16MGB-29 inkl. Schraube	Captive nut to no S16MGB-29 including screw	3
S46MGB-29	Haltebügel Motorhaubenstange unten	Bracket prop mounting lower	1
i117	Mutter UNF 3/16 x 1/8"	Nut UNF 3/16 x 1/8"	8
KA300MGB	Gasfeder-Kit Motorhaube	Bonnet stay kit	1

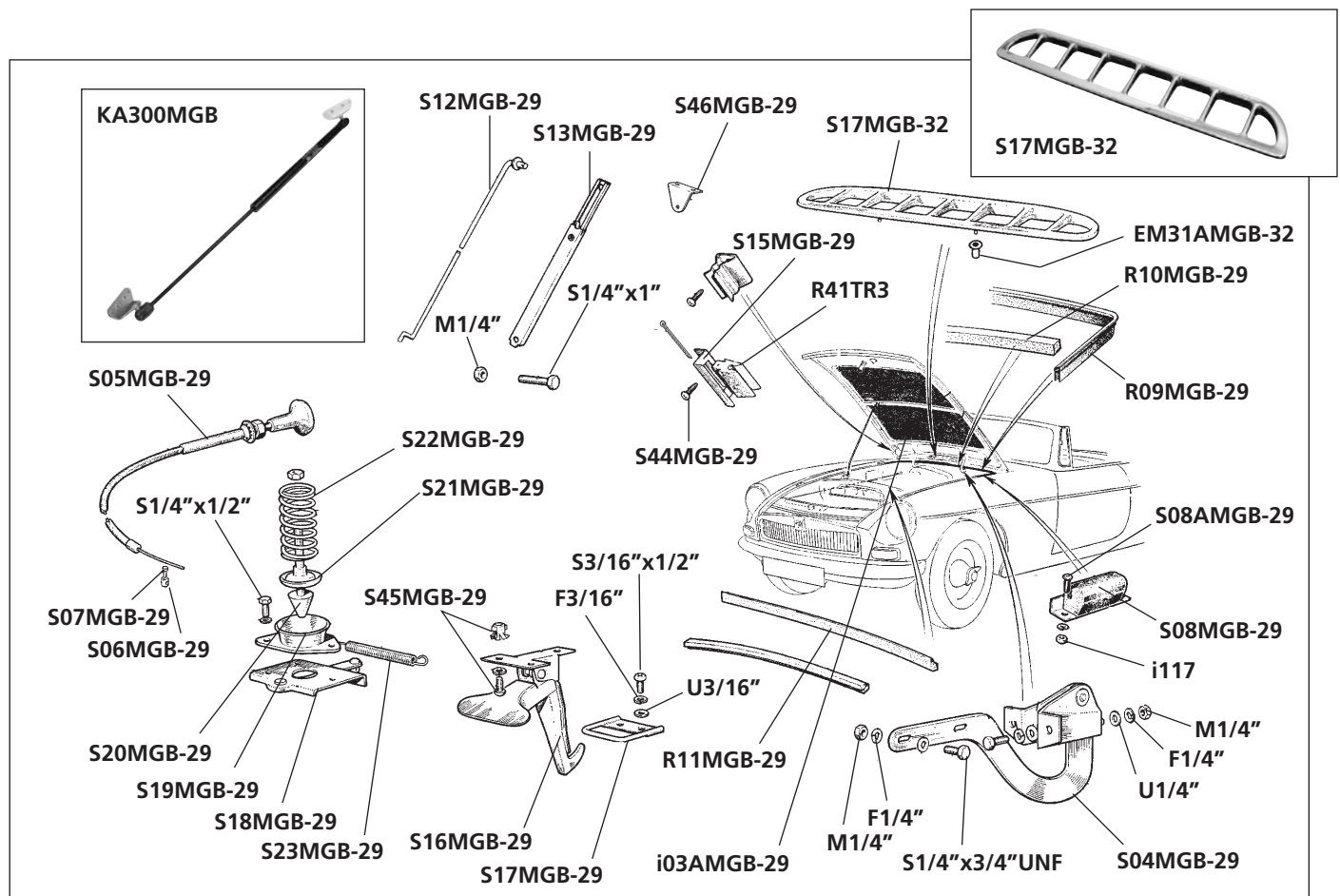

No.	Bezeichnung	Anzahl
EM28MGB-32	Emblem Kofferraumdeckel/Heckklappe Plastik	1
EM28AMGB-32	Emblem Kofferraumdeckel/Heckklappe MG Metall	1
EM28BMGB-32	Emblem Kofferraumdeckel/Heckklappe Gold	1
EM29MGB-32	Emblem MGB	1
EM29MGC	Emblem "MGC" für Kofferdeckel MGC Roadster	1
EM30AMGB-32	Abzeichen MGB-GT schwarz/silber	1
EM30BMGB-32	Abzeichen MGB-GT schwarz/gold	1
EM30CMGB-32	Abzeichen MGB-GT blau/silber	1
EM30DMGB-32	Abzeichen MGB-GT rot/silber	1
EM31MGB-32	Abzeichen B	1
EM32MGB-32	Abzeichen GT	1
EM33MGB-32	Abzeichen MGB-GT	1
EM33MGC	Abzeichen "MGC GT" MGC/GT Heckklappe	1
EM34MGB-32	MG-Abzeichen auf Gummi-Stosstange silber	1
EM34AMGB-32	MG-Abzeichen auf Gummi-Stosstange gold	1
EM34BMGB-32	MG-Abzeichen auf Gummi-Stosstange rot	1
EM35SPT	Abzeichen Leyland am Kotflügel	1
EM44MGA-03	Emblem MG-Octagon (3 teilig)	1
EM46MGB-32	MG-Abzeichen zu Kühlergrill S39MGB-32	1
EM48MGB-32	MG-Abzeichen Kühlergrill schwarz 63-68	1
EM49MGB-32	MG-Abzeichen Kühlergrill rot 72-75	1
EM54MGB-32L	Abzeichen GT hinten auf C-Säule linke Seite	1
EM54MGB-32R	Abzeichen GT hinten auf C-Säule rechte Seite	1

No.	Description	Qty.
EM28MGB-32	Emblem boot lid plastic	1
EM28AMGB-32	Emblem boot lid metal	1
EM28BMGB-32	Emblem boot lid Gold	1
EM29MGB-32	Emblem MGB	1
EM29MGC	Boot Badges MGC Roadster "MGC"	1
EM30AMGB-32	Badge tailgate MGB-GT black/silver	1
EM30BMGB-32	Badge tailgate MGB-GT black/gold	1
EM30CMGB-32	Badge tailgate MGB-GT blue/silver	1
EM30DMGB-32	Badge tailgate MGB-GT red/silver	1
EM31MGB-32	Badge B	1
EM32MGB-32	Badge GT	1
EM33MGB-32	Badge MGB-GT	1
EM33MGC	Letter set "MGC GT"	1
EM34MGB-32	MG-Emblem front rubber bumper silver	1
EM34AMGB-32	MG-Emblem front rubber bumper gold	1
EM34BMGB-32	MG-Emblem front rubber bumper red	1
EM35SPT	Badge Leyland on wing	1
EM44MGA-03	Emblem MG + octagon surround (3 pcs)	1
EM46MGB-32	MG-medaille grille to no S39MGB-32	1
EM48MGB-32	MG-medaille grille black 63-68	1
EM49MGB-32	MG-medaille grille red 72-75	1
EM54MGB-32L	Badge GT rear to C-post lh	1
EM54MGB-32R	Badge GT rear to C-post rh	1

Eine entsprechende Zuordnung der Embleme finden Sie auch ab Seite 126 ff.

A suitable allocation of the emblems you will find also from page 126 onwards.

EM28..MGB-32



EM34MGB-32



EM29MGB-32



EM34AMGB-32



EM29MGC



EM35SPT



EM30AMGB-32



EM44MGA-03



EM30BMGB-32



EM46MGB-32



EM30CMGB-32



EM48MGB-32



EM31MGB-32



EM49MGB-32



EM32MGB-32



EM33MGB-32



EM54MGB-32L



EM33MGC



EM54MGB-32R



Motor MGC

Internal engine MGC

No.	Bezeichnung	Description	Anzahl/Qty.
M2MGC/STD	Hauptlagersatz STD	Main bearing set STD	1
M2MGC/10	Hauptlagersatz +0.010"	Main bearing set +0.010"	1
M2MGC/20	Hauptlagersatz +0.020"	Main bearing set +0.020"	1
M2MGC/30	Hauptlagersatz +0.030"	Main bearing set +0.030"	1
M2MGC/40	Hauptlagersatz +0.040"	Main bearing set +0.040"	1
M04MGA-12	Sicherungskeil Nockenwelle	Camshaft woodruff key	1
MD24MGC	Ölfiltergehäusedichtung	Gasket oilfilter housing	1
M26MGC	Befestigungsschraube Schwungscheibe	Bolt flywheel to crankshaft	6
M30TR4	Steuerkette	Timing chain	1
M40MGA-11	Dichtung Kettenspanner	Gasket tensioner	1
M41MGA-11	Kettenspanner	Tensioner	1
M42MGA-11	Sicherungsblech Kettenspanner	Locktabe tensioner	1
M43MGA-10	Paßstift Kupplung	Dowel	3
M47MGB-02	Sicherungsblech Schwungscheibe	Flywheel lock plate	1
M48TR4	Pleuelbüchse	Bush, connecting rod	6
M50BMG	Dichtring	Sealing ring	1
M50MGC	Filzring Ölfiltergehäuse	Felt washer	1
M51MGC/STD	Pleuellagersatz STD	Rod bearing set STD	1
M51MGC/10	Pleuellagersatz 0.010"	Rod bearing set 0.010"	1
M51MGC/20	Pleuellagersatz 0.020"	Rod bearing set 0.020"	1
M51MGC/30	Pleuellagersatz 0.030"	Rod bearing set 0.030"	1
M51MGC/40	Pleuellagersatz 0.040"	Rod bearing set 0.040"	1
M84MGC	Ölpumpengehäusedichtung	Gasket oil pump	1
M97TR4	Ölfilter	Oil filter	1
M98MGA/TC	Gummikappe Ölmesstab	Dust cap	1
M126MGC	Überdruckventil Öldruck	Oil pressure relief valve	1
M401AH/STD	Kolben-Satz STD	Piston set STD	1
M401AH/20	Kolben-Satz 020"	Piston set 020"	1
M401AH/30	Kolben-Satz 030"	Piston set 030"	1
M401AH/40	Kolben-Satz 040"	Piston set 040"	1
M401AH/60	Kolben-Satz 060"	Piston set 060"	1
M420AH/BJ8STD	Kolbenringe-Satz STD für 6 Kolben (comp.Ring.078" dick,5-Ringe)	Piston ring set STD for 6 pistons (5 ring)	1
M420AH/BJ8.20	Kolbenringe-Satz 020" für 6 Kolben (comp.Ring.078" dick,5-Ringe)	Piston ring set 020" for 6 pistons (5 ring)	1
M420AH/BJ8.30	Kolbenringe-Satz 030" für 6 Kolben (comp.Ring.078" dick,5-Ringe)	Piston ring set 030" for 6 pistons (5 ring)	1
M420AH/BJ8.40	Kolbenringe-Satz 040" für 6 Kolben (comp.Ring.078" dick,5-Ringe)	Piston ring set 040" for 6 pistons (5 ring)	1
M420AH/BJ8.60	Kolbenringe-Satz 060" für 6 Kolben (comp.Ring.078" dick,5-Ringe)	Piston ring set 060" for 6 pistons (5 ring)	1
M433MGC	Nockenwelle	Camshaft	1
M435MGC	Nockenwelle-Lager-Satz	Cam bearing set	1
M439AH	Sicherungsblech Kettenrad Nockenwelle	Lock washer	1
M440AH	Mutter Kettenrad Nockenwelle	Nut	1
M501MGC	Kettenrad Nockenwelle	Camshaft gear	1
M502MGC	Kettenrad Kurbelwelle	Crankshaft gear	1
M508MGC	Stößelstange	Pushrod	12
M509MGC	Stößeltasse	Tappet	12
M511MGC	AT-Kurbelwelle (Schaltgetriebe)	Crankshaft reconditioned (manual gearbox)	1
M511MGC/AUT	AT-Kurbelwelle (Automatikgetriebe)	Crankshaft reconditioned (automatic gearbox)	1
M512MGC	Pilotlager Kurbelwelle Schaltgetriebe	Spigot bush manual gearbox	1
M512MGC/AUT	Pilotlager Kurbelwelle Automatikgetriebe	Spigot bush automatic gearbox	1
M515MGC	Pleuel aufgearbeitet	Connecting rod, reconditioned	6
M519MGC	Pleuelschraube	Bolt, con rod cap.	12
M520AH	Mutter Pleuelschraube	Nut	12
M536AH/005	Anlaufscheiben-Satz 0.005"	Trustwasher set 0.005"	1
M536AH/010	Anlaufscheiben-Satz 0.010"	Trustwasher set 0.010"	1
M536AH/025	Anlaufscheiben-Satz 0.025"	Trustwasher set 0.025"	1
M536AH/STD	Anlaufscheiben-Satz STD	Trustwasher set STD	1
M540AH	Keil Kurbelwelle	Key	2
M601AH	Ausgleichscheibe Kettenrad/Kurbelwelle	Packing washer	A/R
M603AH	Sicherungsblech Kurbelwelle	Lock washer	1
M604MGC	Mutter Kurbelwelle vorne	Nut	1
M606AH	Keilriemenscheibe 3/8" inkl. Hochleistungsschwingungsdämpfer	Pulley and damper crankshaft 3/8"	1
M611MGC	Anlasserzahnkranz Schwungscheibe	Starter ring gear	1
M615MGC	Ölpumpe	Oil pump	1
M616MGC	Reparatursatz Ölpumpe	Oil pump repair kit motor set	1
M619MGC	Filter Ölpumpe	Oil strainer	1

Motor MGC

Internal engine MGC

No.	Bezeichnung	Description	Anzahl/Qty.
ZK01MGA-09	Einstellschraube Ventile	Adjuster, rocker arm	12
ZK2MGC	Kipphebel	Rocker kit	12
ZK3MGC	Lagerbuchse Kipphebelwelle	Bush rocker arm	12
ZK08MGB-02	Klemmkeil Ventile	Cotter valve retaining	24
ZK13MGC	Ventilschaftdichtung	Valve stem gasket	12
ZK23MGC	Einlassventil	Valve, inlet	6
ZK25MGA-09	Ventilführung	Valve guide	12
ZK25MGC	Auslassventil	Valve, exhaust	6
ZK26MGA-09	Bronze Ventilführung	Valve guide, bronze	12
ZK30AH	Ventilfeder-Satz (24 Federn)	Valve spring set (24 spring)	1
ZK32AH	Ventilfeder-Teller oben	Cap valve spring	12
ZK33AH	Unterlage Ventilfeder	Washer valve spring	12
ZK38MGC	Kipphebelwelle	Rocker shaft	1
ZK85SPT	Kontermutter Ventileinstellschraube	Locknut rocker screw	12

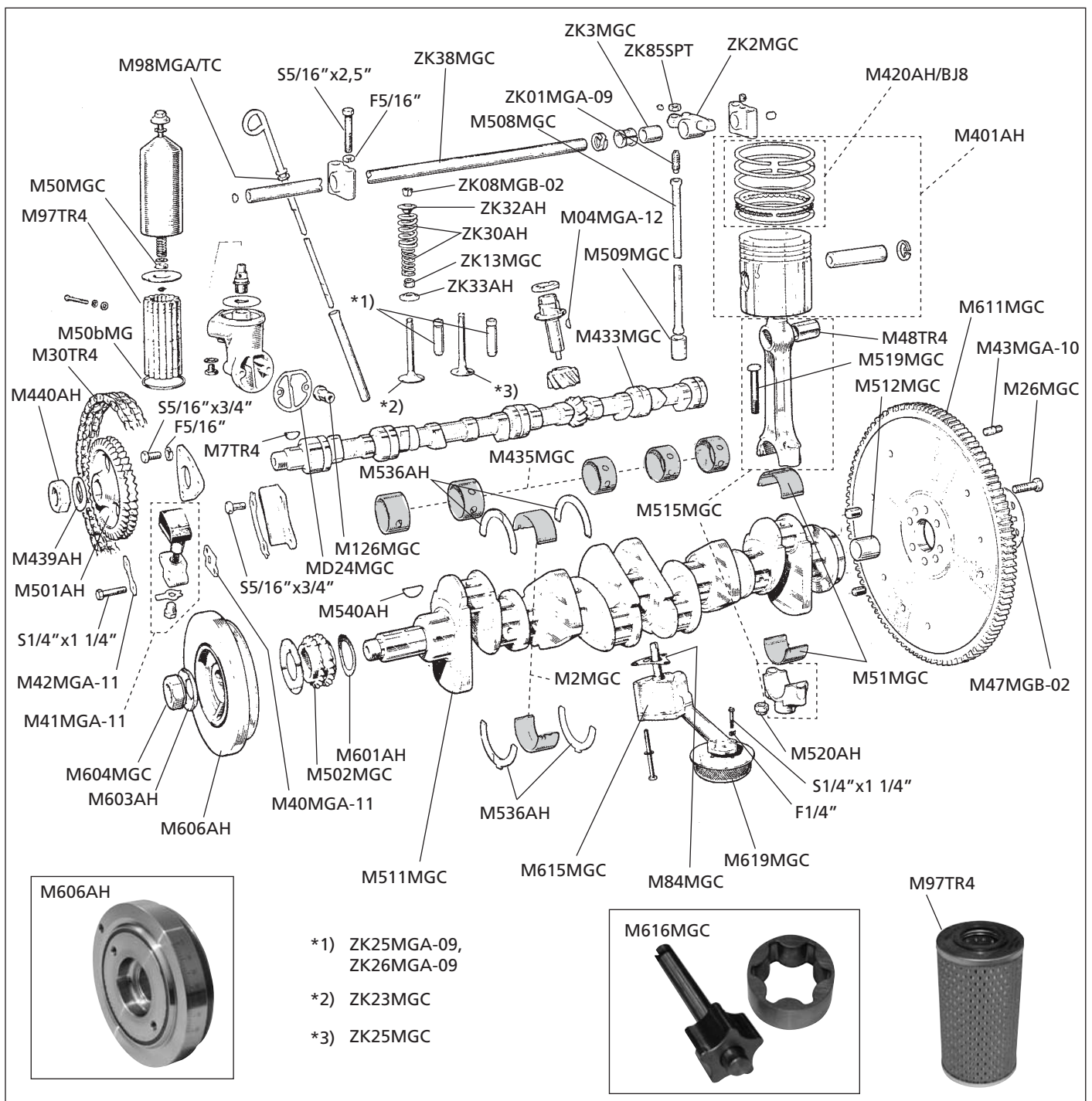

Motor MGC		External engine MGC	
No.	Bezeichnung	Description	Anzahl/Qty.
ZK1MGC	AT-Zylinderkopf	Cylinder head exchange	1
MD1MGC	Zylinderkopf-Dichtsatz	Head gasket set	1
MD2MGC	Zylinderkopf-Dichtung	Head gasket	1
MD3MGC	unterer Motordichtsatz	Lower gasket set	1
K3AH	Fiberscheibe 1/2 x 3/4"	Washer for train tap 1/2 x 3/4"	1
SR4-5/8"	Rundkopfschraube 1/4"x5/8" UNF	Screw	7
ZK5MGC	Stopfen	Plug	1
MD8MGC	Ventildeckel-Dichtung	Valve cover gasket	1
MD9MGC	Einlaß-Auslaß Dichtung	Manifold gasket	1
ZK09MGB-01	Öleinfülldeckel Plastik	Oil filler cap	1
ZK10MGB	Öleinfülldeckel Dichtung	Gasket oil filler cap	1
MD11MGC	Dichtung Steuerkettendeckel	Gasket	1
B12MGC	Stehbolzen 5/16"	Stud 5/16"	2
MD12MGC	O-Ring Dichtung	O-ring gasket	2
MD13MGC	Dichtung Motorplatte hinten	Rear engine mounting plate gasket	1
MD18MGC	Ölwannen-Dichtung	Oil sump gasket	1
ZK19TR6R	Zylinderkopfmutter hochfest	Nut, cylinderhead reinforced	16
ZK19ATR6R	U-Scheibe spezial hart 7/16"	Washer plain 7/16"	16
MD21AH	Unterlagscheibe 5/16"	Washer	5
MD22AH	Dichtung Deckel Motorseite	Gasket	2
MD22MGC	Dichtung Deckel vorne	Gasket side cover front	1
MD23MGC	Dichtung Wasserdeckel	Gasket wather manifold	1
K25MGA-32	Dichtung an Zylinderkopf	Gasket	1
ZK26MGA-08	Abdeckplatte Heizungskanal	Plate, blanking	1
ZK26MGC	Heizungsanschluss	Elbow heater outlet	1
M27MGA-12	Wasser-Ablasshahn	Train tap eng block	1
S31AMGB-31	Stehbolzen 3/8"	Stud 3/8"	15
FS33	Froststopfen Ø 1 5/16"	Core plug Ø 1 5/16"	1
M35MGC/L	Stehbolzen Zylinderkopf lang	Stud cylinderhead long	7
M35MGC/K	Stehbolzen Zylinderkopf kurz	Stud cylinderhead short	7
M36AH	Zylinderkopfmutter	Nut, cylinderhead	16
ZK40MGB	Aufkleber Ventildeckel "MG"	Sticker valve cover "MG"	1
FS42	Froststopfen Ø 1 5/8"	Core plug Ø 1 5/8"	5
M44MGB-02	Simmerring Kurbelwelle	Crankshaft oil seal	1
M47MGB	Schraube Hauptlagerdeckel (ersetzt frühe Stehbolzen)	Bold main bearing cap (raplaced early stud)	14
M47MGA/TC	Abdeckblech für Benzinanschluß	Blanking plate	1
M48MGA/TC	Abdeckblech Dichtung	Gasket blanking plate	1
M74VO	Kupferdichtung 3/4"	Copper washer 3/4"	1
M90MGA/TC	Ölablaßschraube	Drain plug	1
M90MGA/TC-M	Ölablassschraube magnetisch	Drain plug magnetic	1
M113MGC	Froststopfen-Satz	Core plug set	1
M131AH	Simmerring Steuerdeckel	Oil seal, timing cover	1
M707AH	Mutter Messing Krümmer/Zylinderkopf	Nut bronze 3/8" UNF	15
MD17SPT	Dauerplast. Universaldichtung "Marston" 80 ml	Universal jointing compound "Marston" 80 ml	A/R
MD17ASPT	Hochwertige Silikonichtmasse - schwarz "Hylosil" 200 ml	Silicone sealant - black "Hylosil" 200 ml	A/R
MÖ	Motorenöl 20W50 pro Liter	Motor oil 20W50, per liter	A/R



ZK40MGB

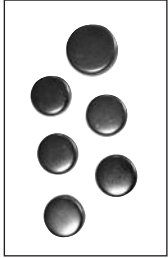

M113MGC

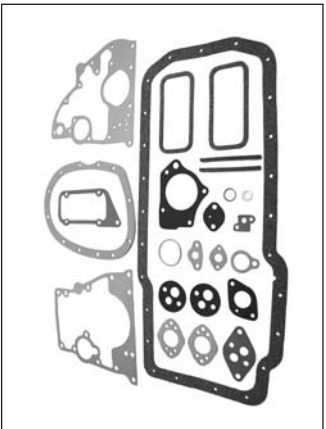
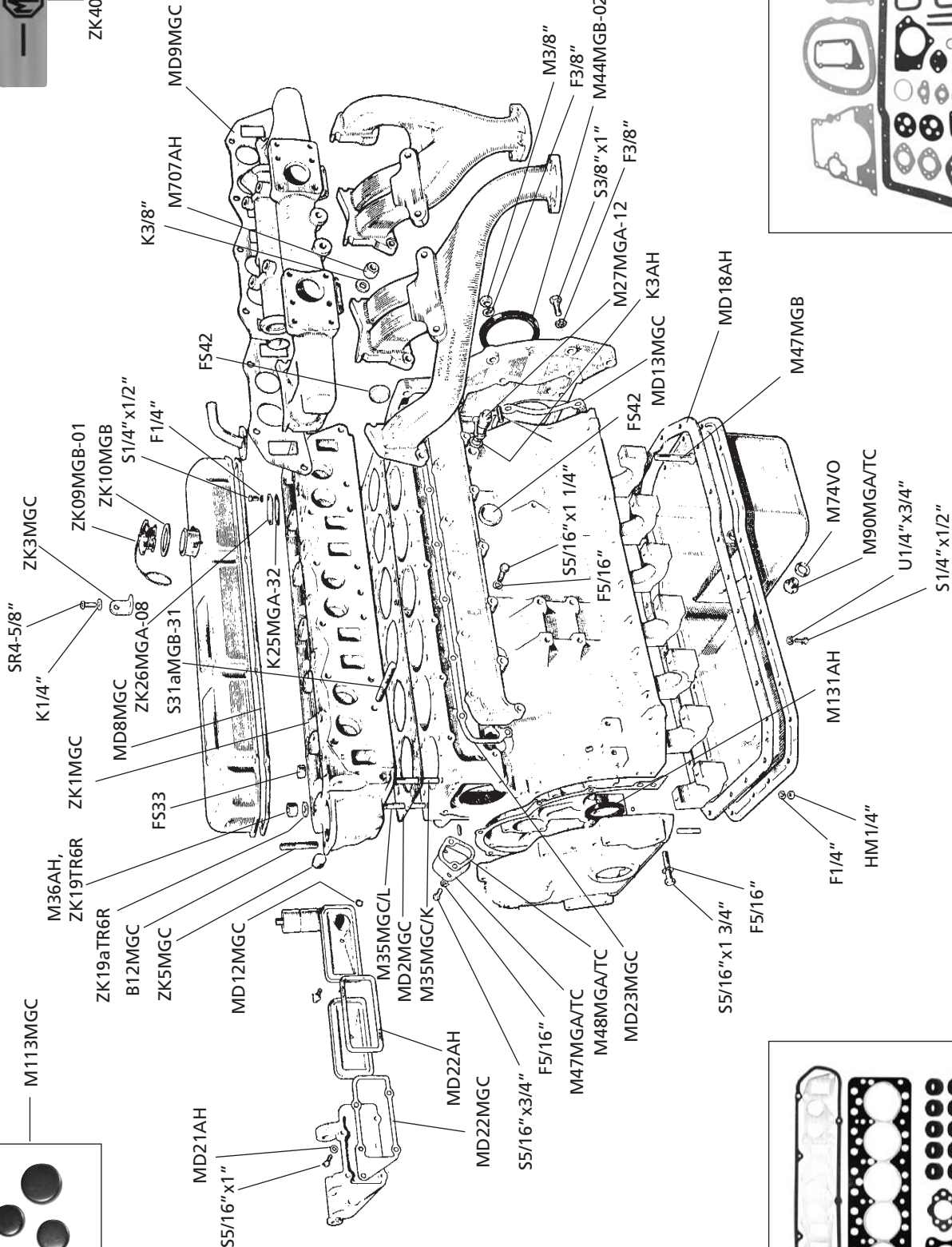

MD3MGC

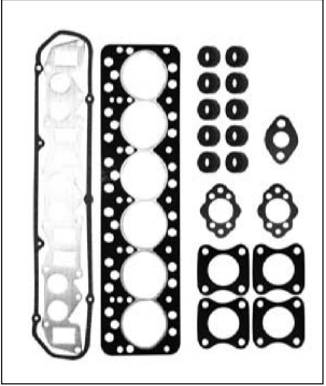

MD1MGC

No.	Bezeichnung	Description	Anzahl/Qty.
G110MGC	Gummi-Lager Getriebehals hinten	Gearbox mounting rubber	2
M121MGC	Motoraufhängung	Engine mounting rubber	2

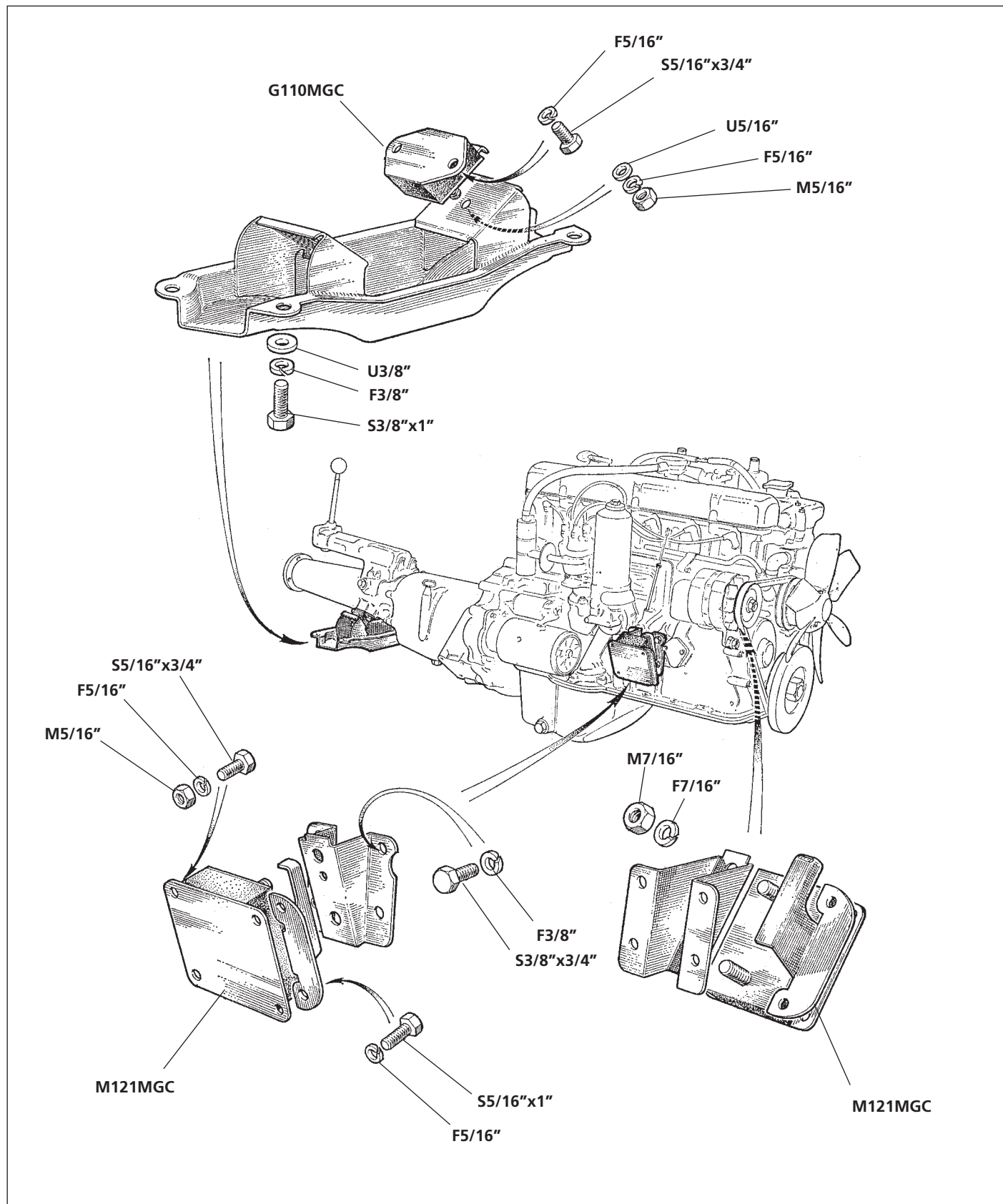

No.	Bezeichnung	Description	Anzahl/Qty.
E1TR4	Unterbrecherkontakt	Point set	1
E2TR6	Verteilerfinger	Rotor	1
E3TR6	Kondensator	Condenser	1
E4TR6	Verteilerkappe	Cap, distributor	1
E5SPT	Befestigungsschraube Unterbrecherkontakt/Kondesator	Screw for point set/condenser	1
E6TR6	Zündkabelsatz	Ignition wires, set	1
E6N-6	Zündkabel Nummernsatz 6-Zylinder	Sleeve set, lead identification 6 cyl.	1
E8MGC	Zündverteiler	Distributor	1
E8aTR	Satz Verteilerfedern	Spring set	1
E9AH/BJ8	Unterdruckdose	Vacuum unit	1
E9TR6	Plastikanschluss Verteiler	Low tension, lead and bush	1
E12MGA-19	Halteklammer Zündverteiler	Mounting plate ignition coil	1
E13SPTMK4	Zündkerze	Spark plug	6
E17	Unterdruckleitung 1,5m 2 x Anschlussgummis	Vacuum pipe 1.5 m 2x rubber connection	1
E300MGC	AT-Anlasser	Starter, exchange	1
E303TR4	Satz Kohlen Anlasser	Brush set, starter	2
E310MGB	Lichtmaschine	Alternator	1

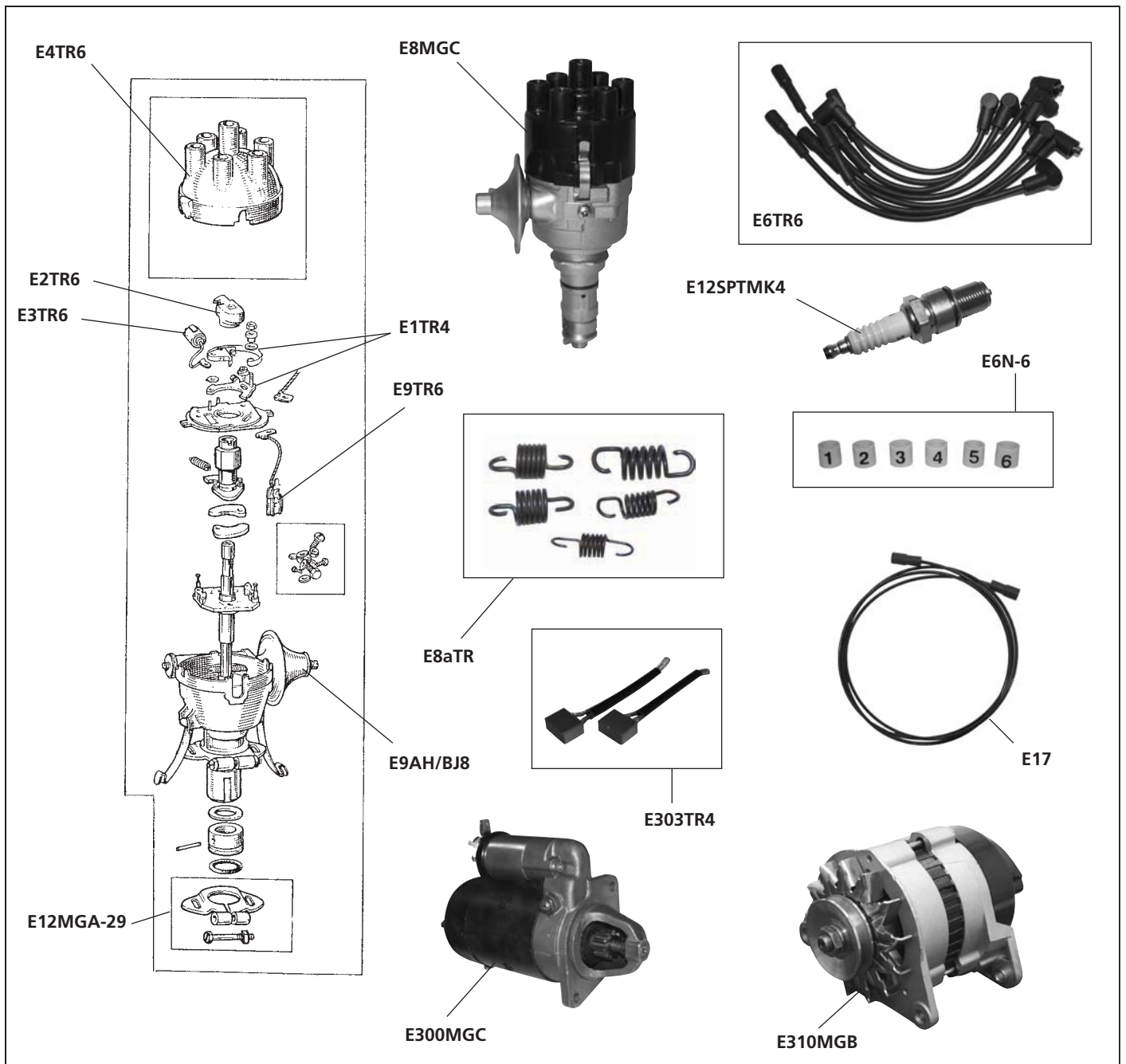

Auspuffanlage Standard MGC**Standard exhaust system MGC**

No.	Bezeichnung	Description	Anzahl/Qty.
A1MGC	Hosenrohr	Front pipe	1
A2MGC	Vorschalldämpfer	Front silencer	1
A3MGC	Endschalldämpfer	Rear silencer	1
A4MGC	Halter Auspuff Mitte oben	Exhaust bracket middle top	1
A5MGC	Halter Auspuff Mitte unten	Exhaust bracket middle buttom	1
A6MGC	hinterer Auspuffhalter unten	Rear bracket exhaust mounting buttom	2
A7MGC	Auspuffschelle vorne	Exhaust clip front	1
A18MGB-14	hinterer Auspuffhalter	Rear bracket exhaust mounting	1
A19MGB-14	Haltebügel Auspuff hinten ab 1969	Bracket hinge rear exhaust mounting	1
A21MGB-14	Auspuff Aufhängungsgummi hinten	Rubber hanger rear	4
A29MGA-14	Dichtring Auspuffrohr	Gasket	2
A30MGA-14	Stehbolzen Auspuff-Krümmen	Stud manifold	6
A32MGA-14	Mutter UNF 3/8" " Messing "	Nut 3/8"	6
A37MGB-14	Auspuff Isolierscheibe hinten	Insulation washer	8
A38MGA-14	Auspuff-Aufhängungsgummi mitte	Mounting intermediate	1
A53MGA-14	Buchse/Gehäuse-Satz mittlere Auspuffhalter	Exhaust bracket kit	1
SCH59/B	Auspuffschelle hinten	Exhaust clip rear	1

Sportauspuffanlage MGC**Sport exhaust system MGC**

No.	Bezeichnung	Description	Anzahl/Qty.
A1MGC	Hosenrohr	Front pipe	1
A2MGC/S	Verbindungsrohr Sport	Link pipe, sport	1
A3MGC/S	Endschalldämpfer Sport	Rear silencer, sport	1
A4MGC	Halter Auspuff Mitte oben	Exhaust bracket middle top	1
A5MGC	Halter Auspuff Mitte unten	Exhaust bracket middle buttom	1
A6MGC	hinterer Auspuffhalter unten	Rear bracket exhaust mounting buttom	2
A7MGC	Auspuffschelle vorne	Exhaust clip front	1
A18MGB-14	hinterer Auspuffhalter	Rear bracket exhaust mounting	1
A19MGB-14	Haltebügel Auspuff hinten ab 1969	Bracket hinge rear exhaust mounting	1
A21MGB-14	Auspuff Aufhängungsgummi hinten	Rubber hanger rear	4
A29MGA-14	Dichtring Auspuffrohr	Gasket	2
A30MGA-14	Stehbolzen Auspuff-Krümmen	Stud manifold	6
A32MGA-14	Mutter UNF 3/8" " Messing "	Nut 3/8"	6
A37MGB-14	Auspuff Isolierscheibe hinten	Insulation washer	8
A38MGA-14	Auspuff-Aufhängungsgummi mitte	Mounting intermediate	1
A53MGA-14	Buchse/Gehäuse-Satz mittlere Auspuffhalter	Exhaust bracket kit	1
SCH59/B	Auspuffschelle hinten	Exhaust clip rear	1

Auspuffanlage Standard / Standard exhaust system

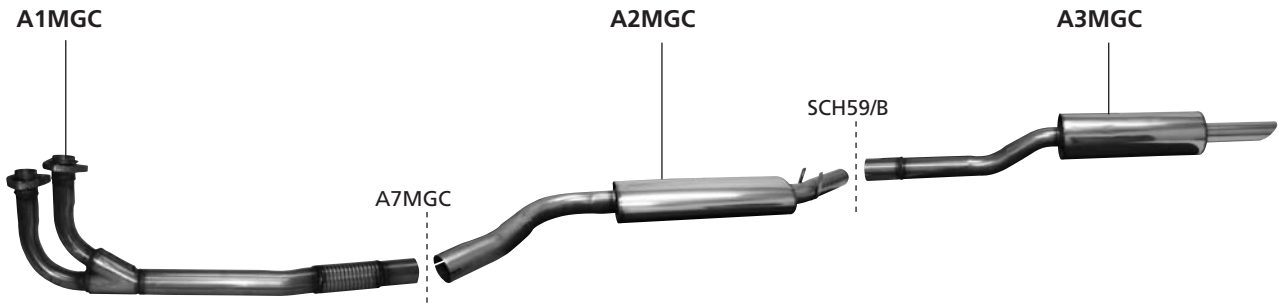

Sportauspuffanlage / Sport exhaust system

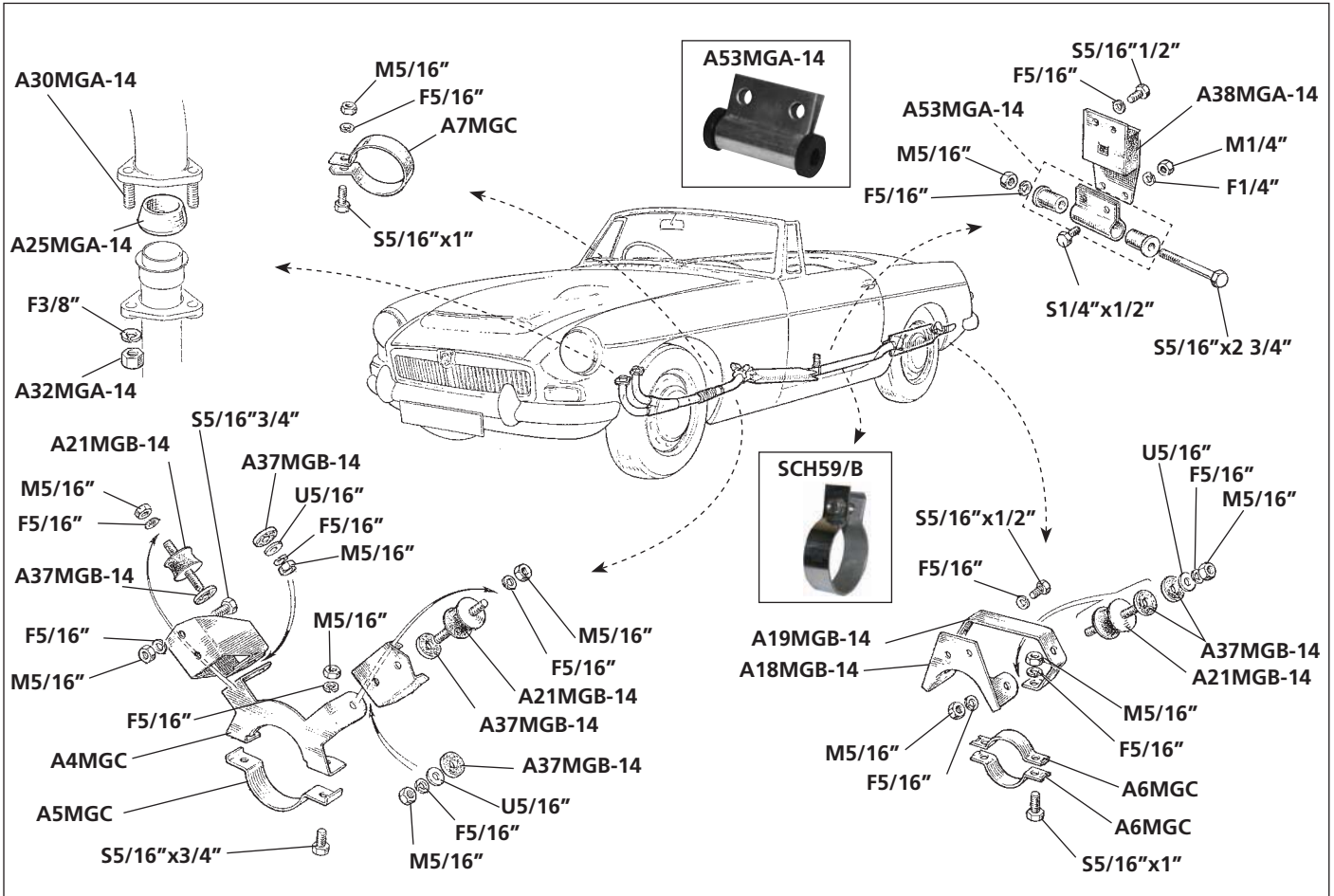
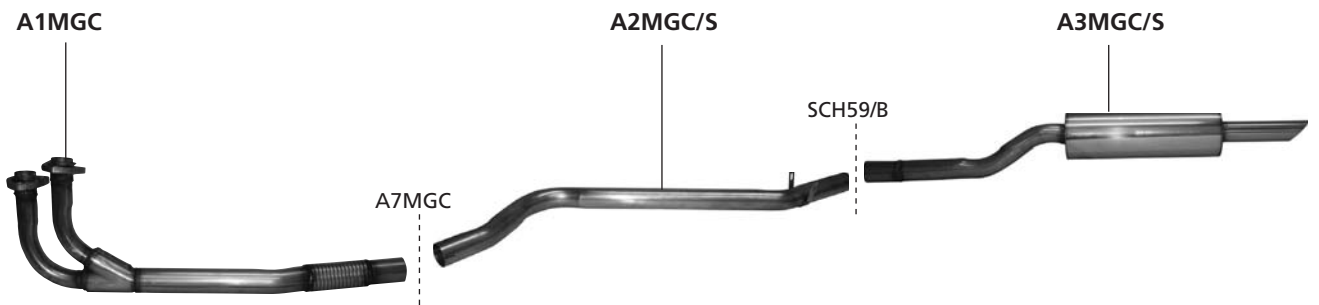

Kühlanlage MGC

Cooling system MGC

No.	Bezeichnung	Description	Anzahl/Qty.
K1MGC	Kühler	Radiator	1
K1MGC/ALU	Hochleistungs Aluminiumkühler	High performance Alu-Radiator	1
K2MGC	Wasserablaßschraube Kühler	Drain plug	1
K3MGC	Kühlerhalteblech seitl. Rechts	Radiator mounting bracket RH	1
K4MGC	Kühlerhalteblech seitl. Links	Radiator mounting bracket LH	1
K05aMGB-12	Deckel Ausgleichsbehälter	Cap tank filler	1
K7	Schlauchschelle 8-12mm	Hose clip 8-12mm	A/R
K10SPT	Schlauchschelle 30-45mm	Hose clip 30-45mm	4
K11MGC	Kühlerhalteblech oben rechts	Radiator upper bracket RH	1
K12MGC	Kühlerhalteblech oben links	Radiator upper bracket LH	1
K23MGC	Kühlwasserschlauch unten	Radiator hose buttom	1
K24MGC	Kühlwasserschlauch oben	Radiator hose top	1
K28MGC	Halter Ausgleichsbehälter	Clip tank retaining	1
K34MGC	Schlauch Halteklammer	Hose clip	1
R71MGB	Filz Kühler (74cm)	Felt seating	2
V78SPT	Schlauch 8mm / 5/16" pro Meter	Hose 8mm/ 5/16" par meter	A/R
K4SPT	Thermostat 74°	Thermostat 74°	1
K4VOB18	Thermostat 82°	Thermostat 82°	1
MD6SPT	Thermostatdichtung	Thermostat gasket	1
K9aSPT	Schlauchschelle 16-27mm	Hose clip 16-27mm	A/R
K22MGA-15	Dichtung Wasserthermostat	Gasket thermostat housing	1
M22MGC	Keilriemen	Fan belt	1
M37MGC	Dichtung Wasserpumpe	Water pump gasket	1
M39MGC	Wasserpumpe	Water pump	1
K51MGC	Wasser-Einfülldeckel	Cap water filler	1
K52MGC	Kupfer Dichtung 5/8" innen	Copper washer	1
K53MGC	Adapter an Wasserpumpe	Adaptor wather pump	1
K54MGC	Adapter Wasserpumpe By-Pass	Adaptor wather pump By-Pass	1
K55MGC	Kupferdichtung By-Pass Adapter	Copper washer	1
K56MGC	Schlauch Wasserpumpe By-Pass	By-Pass hose water pump	1
K57MGC	Verbindungsschlauch Wasserpumpe zu Rücklaufrohr	Connecting hose	1
K58MGC	Wasser Rücklaufrohr zu Wasser-Pumpe	Water return pipe	1

Kühlanlage / Cooling System MGC

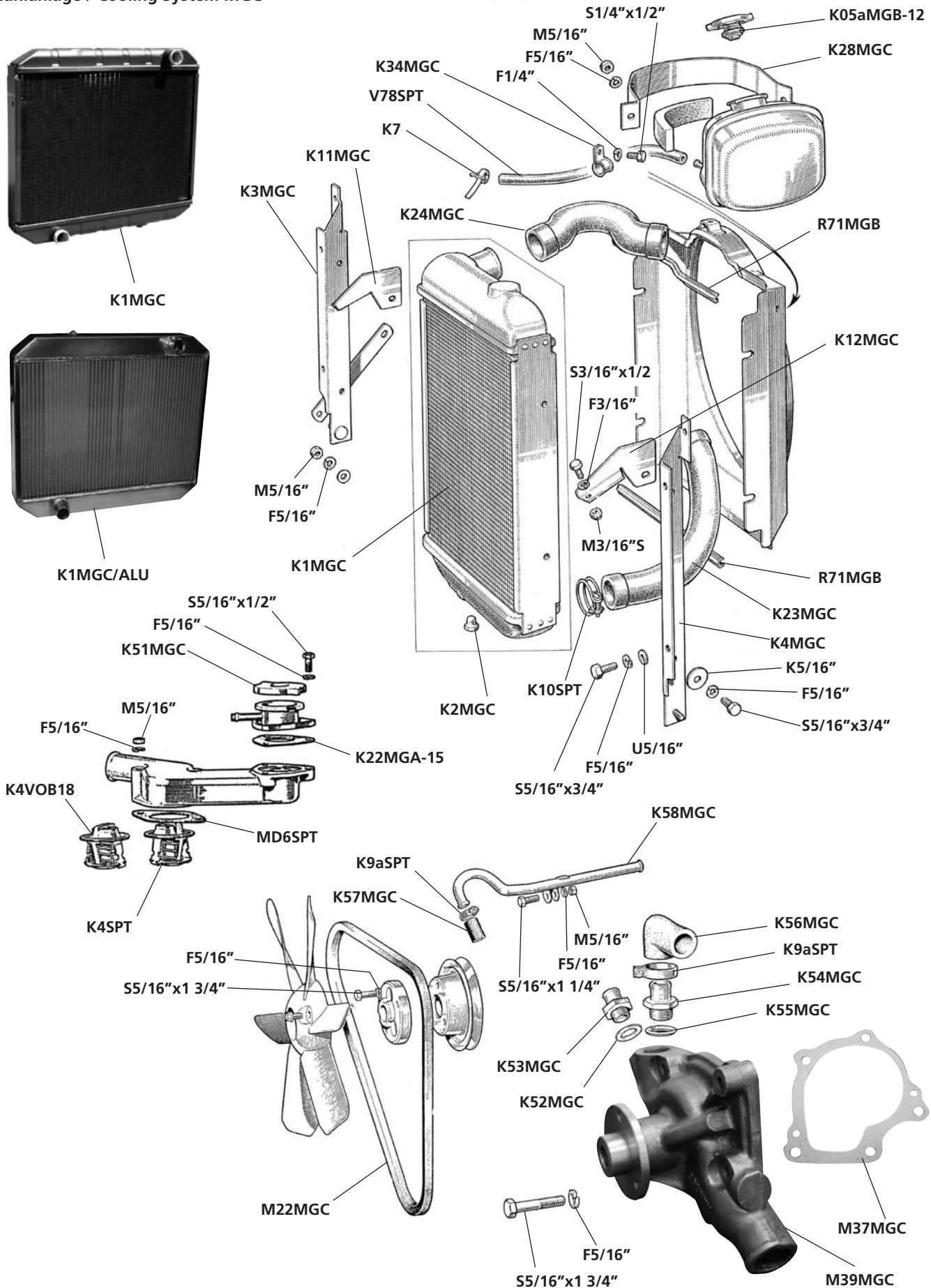

Kupplung MGC		Clutch MGC	
No.	Bezeichnung	Description	Anzahl/Qty.
C3MGC	Kupplungsscheibe	Clutch plate	1
C5AH	Kupplungsautomt	Clutch cover	1
C9AH	Kupplungs-Lager	Clutch bearing	1
C12MGC	Kupplungsleitung	Clutch pipe	1
C12MGC/RHD	Kupplungsleitung Rechtslenker	Clutch pipe RHD	1
B14MGA-20	Rückholfeder Pedale	Brake- /Clutchpedal return spring	2
B14MGA-AQ	Kupplungsschlauch stahlummantelt incl. Banjoschraube als Alternative zu B56MGC	Clutch hose steel covert incl. Banjo bolt - altern. to no. B56MGC	1
C16MGC	Kupplungsnehmerzylinder	Clutch slave cylinder	1
C17MGC	Reperatursatz Kupplungsnehmer	Seal kit slave cylinder	1
C18MGC	Ausrückstange Kupplung	Push rod	1
C19MGC	Halterung Kupplungsleitung	Bracket clutchpipe	1
B19MGA-20	Pedalgummi	Pedal rubber	2
B20MGA-22	Sicherungsblech	Lock plate	1
B21MGA-22	Kupferscheibe 7/16"	Copper washer	1
B22MGA-22	Hohlschraube	Banjo bolt	1
B25MGA-22	Klammer Bremsleitung 3/16" x 11/32"	Pipe clip 3/16" x 11/32"	1
C25MGB-05	Halteclip Ausrücklager	Clip clutch rel bearing	2
C26MGM	Lagerstift 5/16" x 11/16"	Clevis Pin 5/16" x 11/16"	1
C26MGC	Lagerstift 5/16 x 7/8"	Clevis Pin 5/16 x 7/8"	1
C30MGC	Kupplungsgeberzylinder	Clutch master cylinder	1
B56MGC	Kupplungsschlauch	Clutch hose	1
B58C	Kupferdichtring	Copper washer	2
B58D	Zahnscheibe für Kupplungsschlauch	Washer, shaleproof	1
SR61	Splint	Splint pin	2
HM3/8"	Mutter 3/8" UNF halbe Stärke	Nut	1

Kuplung / Clutch MGC

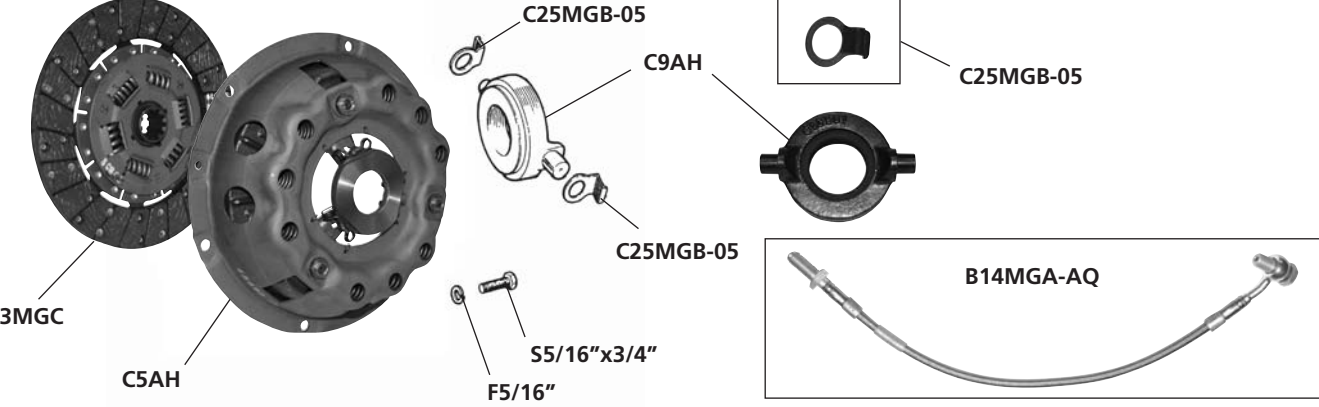
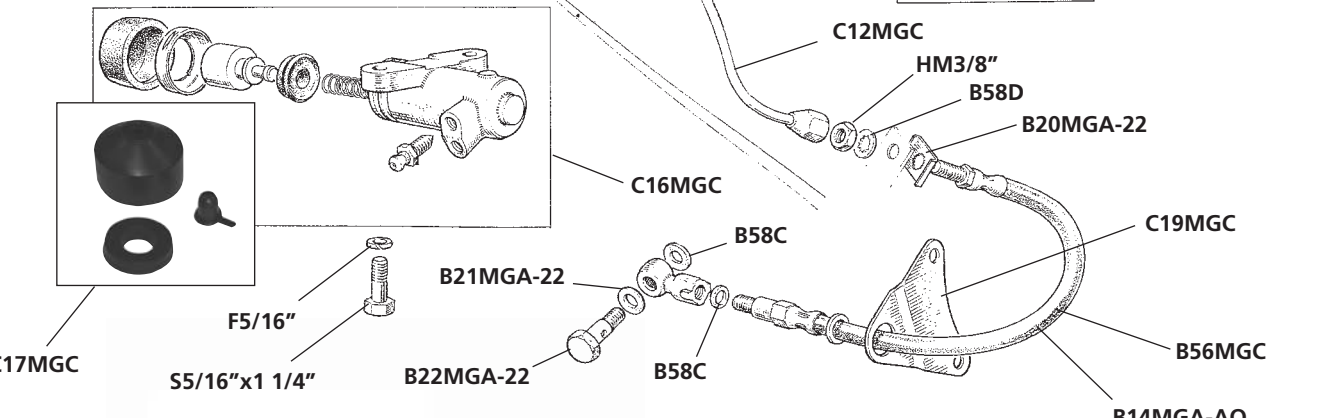
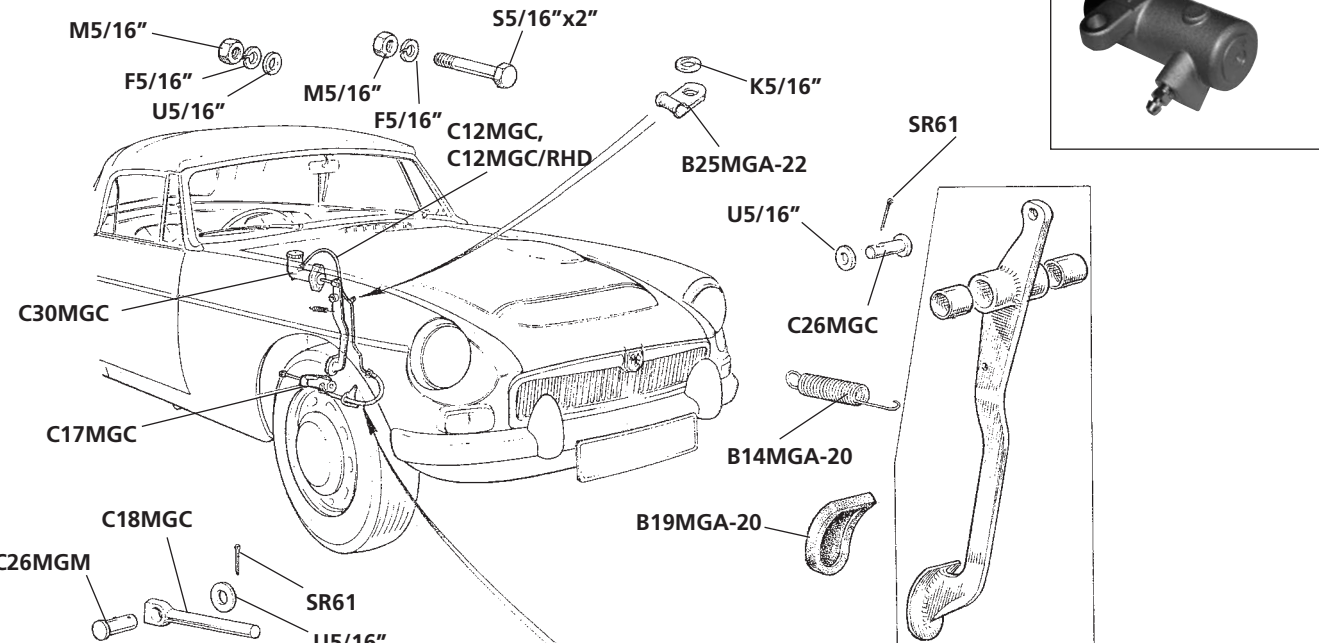
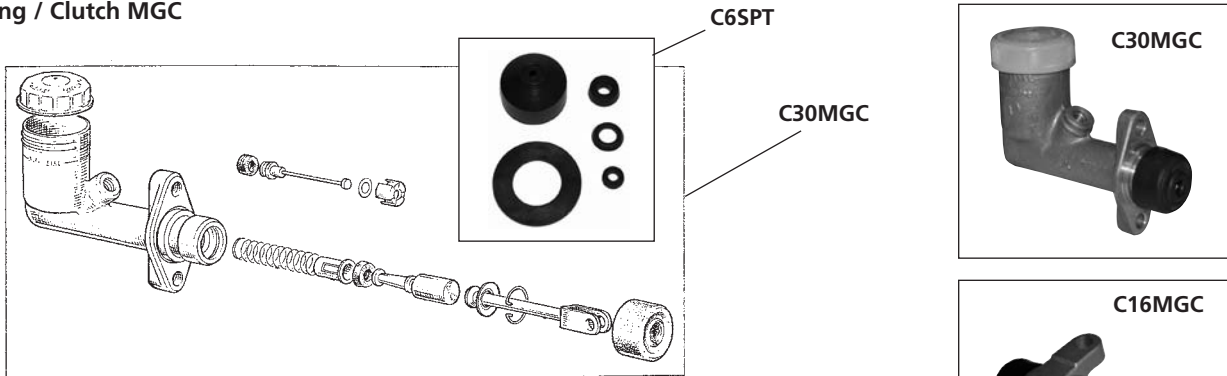

Hinterachse + Kardanwelle MGC

Die meisten Teile stimmen mit der "Tube Achse" des MGB überein - s. hierzu Seite 60. Die wichtigsten Unterschiede des MGC sind nachstehend aufgelistet:

Rear Suspension + Drive Shaft MGC

The most parts are agree with the "Tube Axle" MGB - see page 60. The important differences from MGC are listed below

No.	Bezeichnung	Description	Anzahl/Qty.
D27MGC/LH	Speichenradnabe hinten links	Hub left for wire wheel	1
D27MGC/RH	Speichenradnabe hinten rechts	Hub right for wire wheel	1
D55VO	Kreuzgelenk	Universal joint	2
D57TR	Schraube Kardanwelle an Getriebe (4-Gang Getriebe/ Differential)	Bolt propshaft to gearbox (4 speed gearbox/ differential)	4/8
D57MGC	Schraube Kardanwelle an Overdrive (4-Gang Getriebe/ Overdrive)	Bolt propshaft to overdrive (4 speed gearbox/ overdrive)	4
HA60MGC	Kardanwelle	Prop shaft	1
HA66MGC	Gummimanschette	Rubber boot	1
HA100MGC	Blattfeder Roadster MGC	Rear spring roadster	2
HA101MGC	Blattfeder MGC - GT	Rear spring gt	2
D146AH	Sicherungsblech Getriebe Flansch	Lockwasher	2

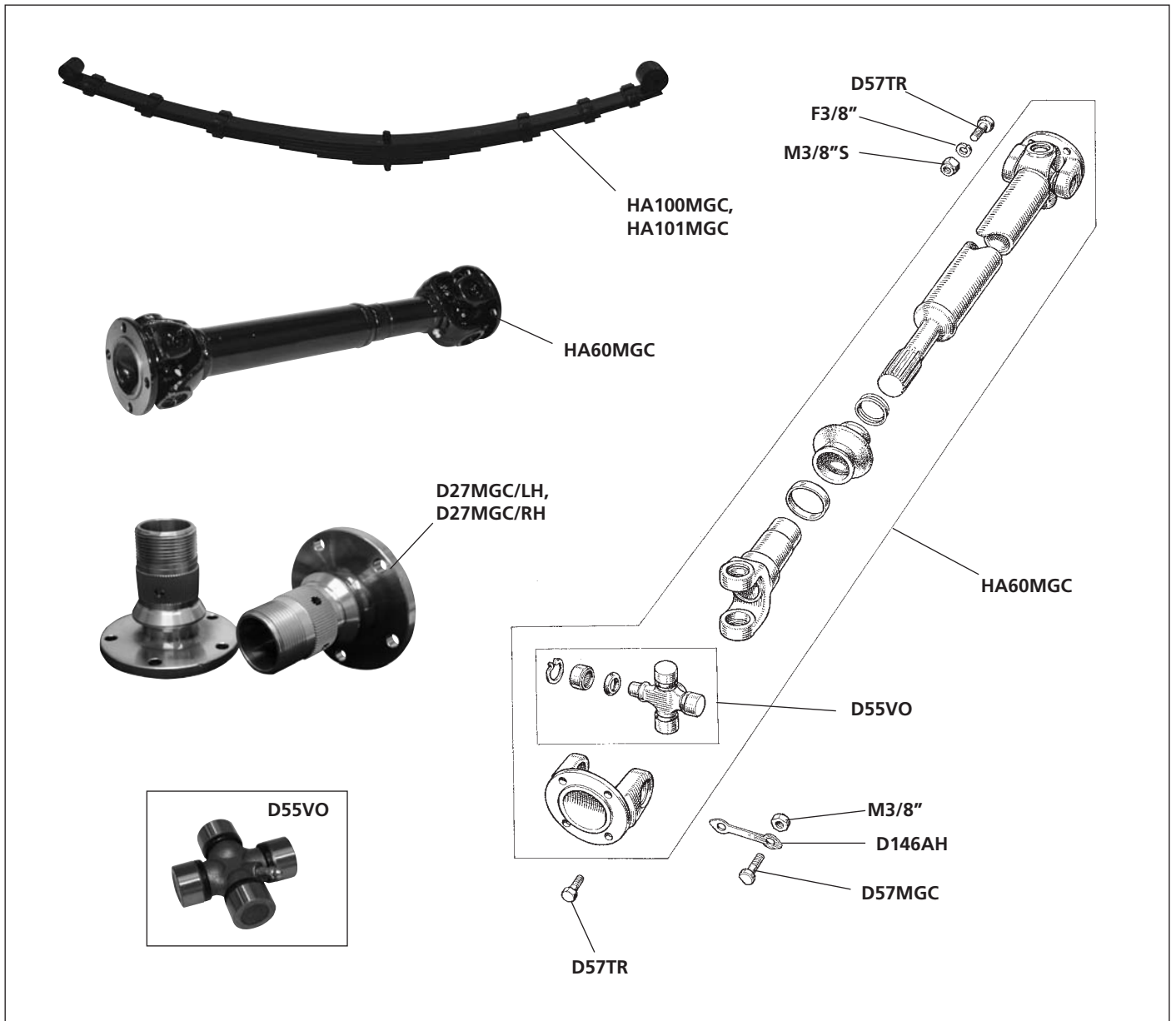

Lenkung MGC

Steering MGC

No.	Bezeichnung	Description	Anzahl/Qty.
L01MGC	Lenkung Linkslenker	Steering rod lhd	1
L01MGC/RHD	Lenkung Rechtslenker	Steering rod rhd	1
L05MGB-17	Spurstangenendkopf	Trock rod end	2
L26AMGC	Kreuzgelenk Lenksäule	Universal joint	1
L31MGA-27	Ausgleichscheibe Lenkung	Shim rod to bracket	A/R
L44MGB	Lenkmanschettensatz	Rod bellars set+clip	1
i105	Popniete 1/8"x7/16"	Pop rivet 1/8"x7/16"	A/R

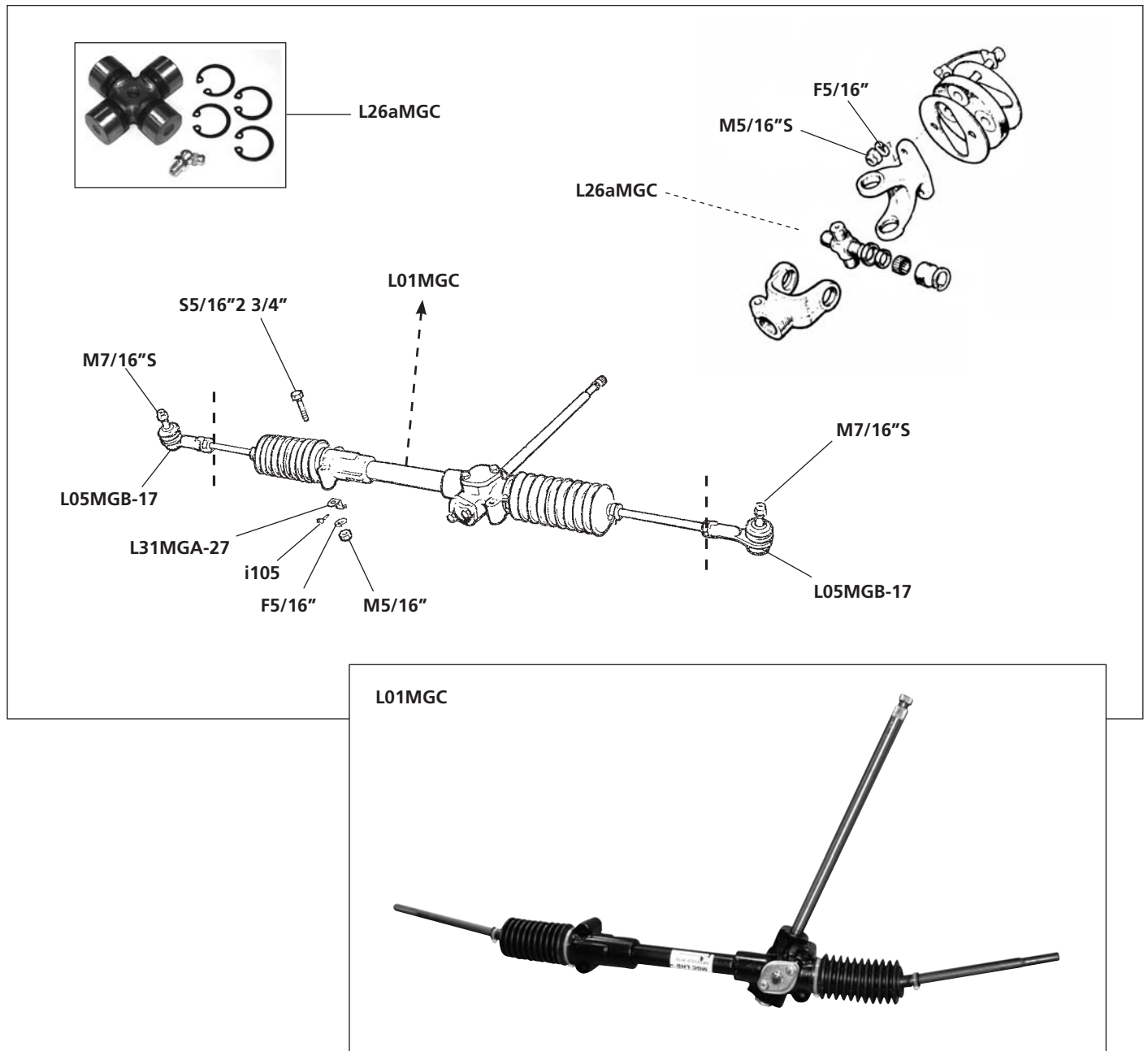

Vorderachse MGC

Front Suspension MGC

No.	Bezeichnung	Description	Anzahl/Qty.
VA6TR	Kronenmutter 7/16"	Slotted nut	4
VA6MGC	Stoßdämpfer Vorderachse	Shock absorber	2
VA6MGC/SPAX	Stoßdämpfer Spax einstellbar Vorderachse	Spax adjustable shock absorber	2
VA08MGB-18	Lagerbolzen Achsträger oben	Top fulcrum pin	4
VA09MGB-18	Lagerbuchse	Bush top link	4
VA09MGB/P	Satz-Polyurethan Buchsen oben (ersetzt VA09MGB-18)	Set polyurethan bearing bush (replace VA09MGB-18)	4
VA13MGC	Schraube Vorderachse unten	Pin lower	2
VA14MGC	Manschette Vorderachse unten	Collar split cover	2
VA15MGC	Abstandsrohr Vorderachse unten	Distance tube	2
VA16MGC	Verbinder Dreischlenker Vorderachse unten	Lower swivel pin	2
VA17MGC	Buchse Vorderachse unten	Bottom bush king pin	2
VA18MGC	Nylon Scheibe Vorderachse unten	Nylon washer	4
VA11MGC	Anschlaggummi Vorderachse oben	Bump stop	2
ZK19TR6	Zylinderkopfmutter	Nut	A/R
VA21MGC	Lagerbolzen Vorderachse unten	Fulcrum rod	2
VA24SPT	Kronenmutter 1/2"	Slotted nut	4
VA46MGC	Buchse Vorderachse unten	Bush	2
HA50GT6	Silentgummi Rotoflexachse Vorderachse oben	Bush upper arm inner	4
VA90MGC/P	Satz-Polyurethan Buchsen Vorderachse	Set polyurethan bushes front axle	1

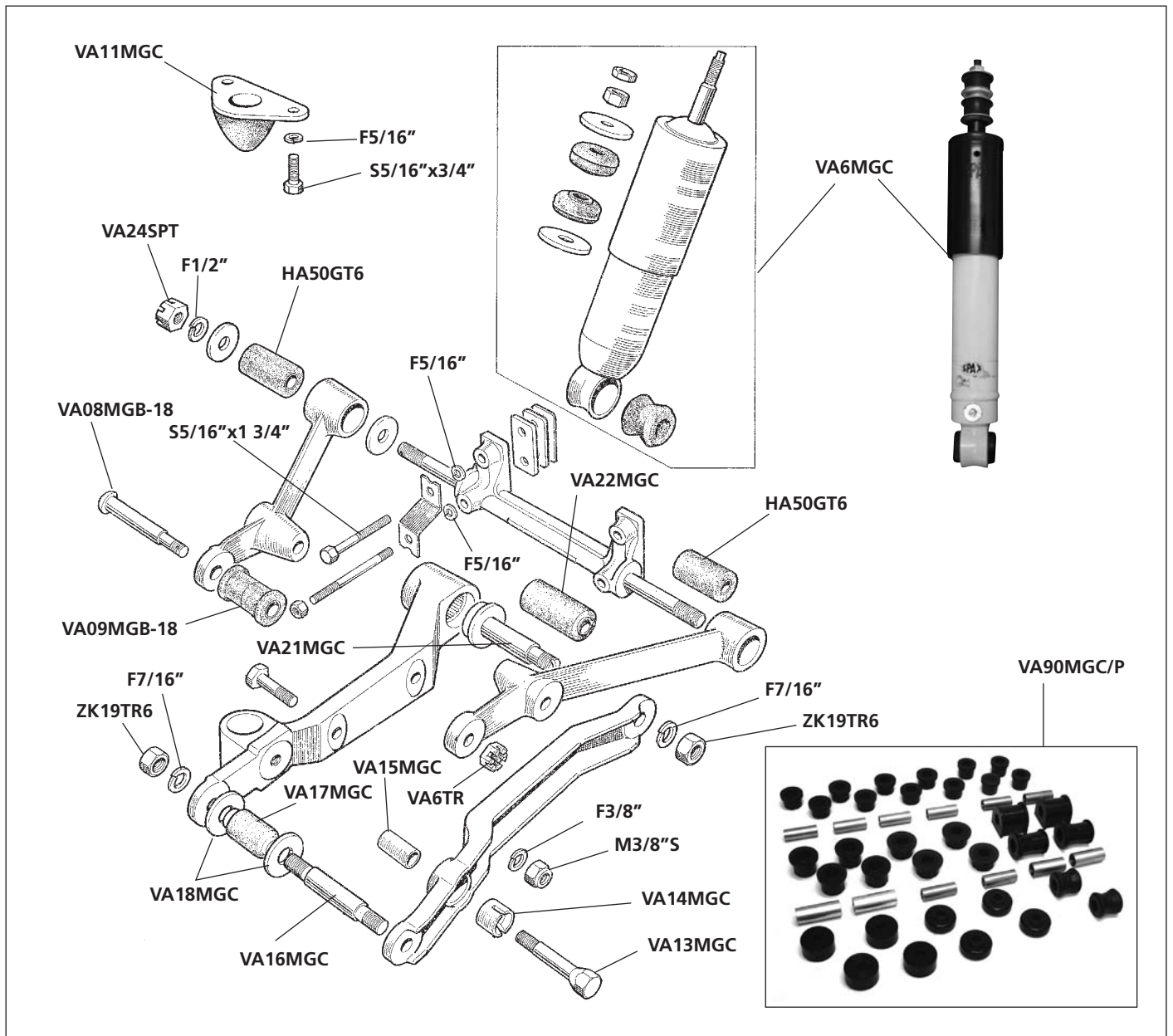

Vorderachse MGC

Front Suspension MGC

No.	Bezeichnung	Description	Anzahl/Qty.
VA24SPT	Kronenmutter 1/2" UNF	Slotted nut 1/2" UNF	2
HA27MGB-19	obere + untere Halteklammer Stabi hinten 11/16" Stabi	End stop kit anti-roll bar	2
VA51MGB-3/4"N	Neopren Lager Satz Stabilisator 19 mm	Neopren bush mountings to 19mm anti roll bar	1
VA51MGB-7/8"	Neopren Lager Satz Stabilisator 22 mm	Neopren bush mountings to 22mm anti roll bar	1
VA54MGB	Büchse Stabilisator außen Vorderachse	Anti roll bar bush	2
VA100MGC	Stabilisator	Anti roll bar	1
VA100MGC-3/4"	Stabilisator verstärk 19mm dick	Anti roll bar uprted 19mm thick	1
VA100MGC-7/8"	Stabilisator verstärk 22mm dick	Anti roll bar uprted 22mm thick	1
VA116MGC	Schubstrebe Vorderachse	Tie bar front suspension	2
VA117MGC	Schraube Schubstrebe	Screw tie bar	2
VA120MGC	Gummibuchse Schubstrebe	Bush tie bar	4
VA120MGC/P	Polyurethan Buchse Schubstrebe	Polyurethan bush tie bar	4
VA122MGC	Mutter + Schraube Schubstrebe	Nut & bolt tie bar	2
VA126MGC	Stabilisatorgelenk	Link arm anti roll bar	2
VA129MGC	Schraube Stabilisatorgelenk	Screw link arm anti roll bar	2
VA132MGC	Haltegummi Stabilisator Vorderachse	Anti roll bar bush	2
VA132MGC/P	Polyurethan Haltegummi Stabbi Vorderachse	Polyurethan anti roll bar bush	2

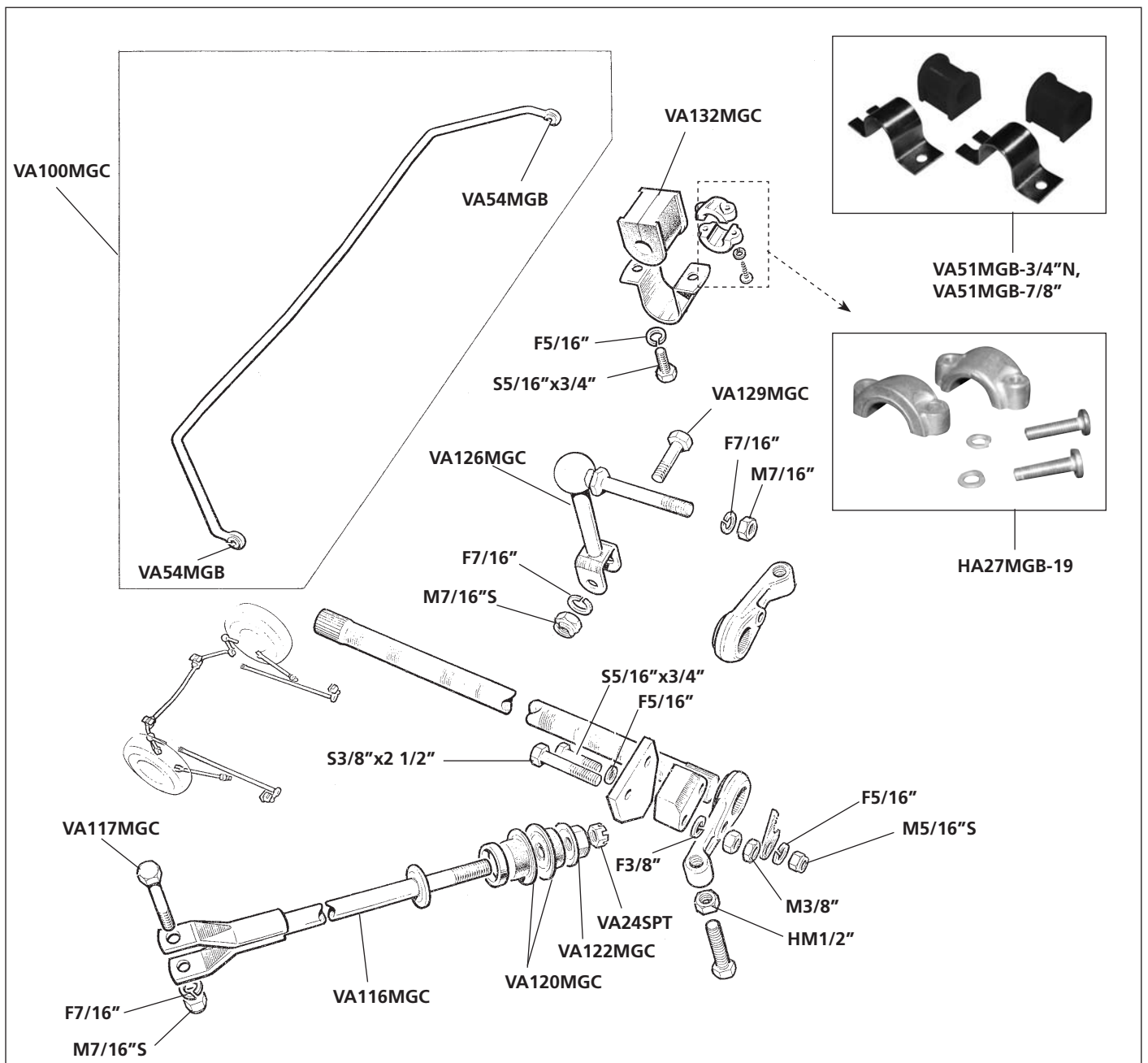

Vorderachse MGC

Front Suspension MGC

No.	Bezeichnung	Description	Anzahl/Qty.
VA11MGA-24	Fettkappe Radnabe vorne Stahlfelge	Grease cap front hub	2
VA28MGB-18	Scheibe Bronze	Trust washer brance	2
VA28MGB/0.055	Einstellscheibe 0.055"	Trust shim 0.055"	A/R
VA28MGB/0.060	Einstellscheibe 0.060"	Trust shim 0.060"	A/R
VA28MGB/0.065	Einstellscheibe 0.065"	Trust shim 0.065"	A/R
VA31MGB-18	Schmiernippel 45°	Grease nipple 45°	2
HA36MGA-25	Schmiernippel	Grease nipple	2
VA36MGB-18	Radlagersatz vorne	Wheel bearing	2
VA37MGB-18	Distanzhülse Radlager	Distance tube wheel bearing	2
D37AMGB-16	Radmutter Rostyle + Minilite chrom	Wheel nut rostyle + minilite chrome	16
D37MGB-16	Radmutter	Wheel nut	16
VA38MGB-18	Satz Ausgleichsscheiben	Shim adjusting wheel bearing kit	A/R
VA39MGB-18	Sicherungs-Scheibe Radlager	Washer front wheel bearing	2
VA40MGB-18	Sicherungsmutter Lager	Nut slotted	2
VA42MGB-18	Radbolzen	Wheel stud	8
VA45MGC/R	Speichenradnabe RH vorne	Hub wire wheel RH	1
VA45MGC/L	Speichenradnabe LH vorne	Hub wire wheel LH	1
VA46MGB-18	Fettkappe für Speichenfelgennabe	Grease cap front wire wheel	2
VA47MGB-18	Bolzen 7/16"	Bolt 7/16"	2
VA53MGC	Buchse Achsträger oben	Top bush kingpin	2
VA54MGC	Buchse Achsträger unten	Top bush kingpin	2
VA55MGC	Achsträgerbolzen Paar	Kingpin set pair	1
VA57MGC	O-Ring Achsträgerbolzen	O-ring king pin	4
VA60MGC	Staubschutzrohr oben	Tube dust excluding top	2
VA61MGC	Feder Staubschutzrohr	Spring dust tube	2
VA62MGC	Staubschutzrohr unten	Tube dust excluding bottom	2
VA67MGC	Mutter oben Achsträgerbolzen	Top nut king pin	2
VA68MGC	Sicherungsblech für VA67MGC	Locking plate for VA67MGC	2

Vorderachse / Front Suspension MGC

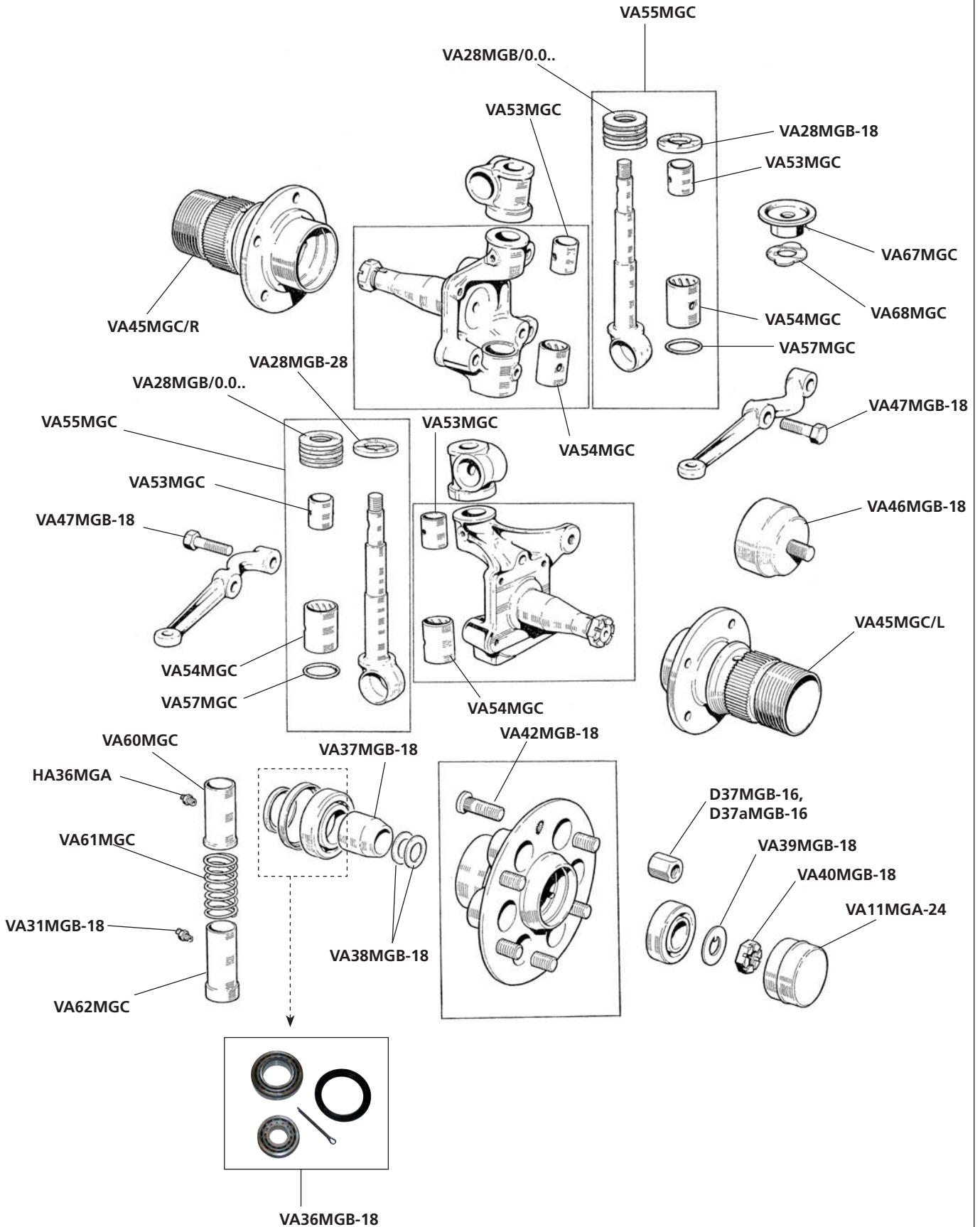

Bremssättel und -scheiben vorne MGC

Front brake callipers & brake discs MGC

No.	Bezeichnung	Description	Anzahl/Qty.
B1BTRR	Bremssattel neu rechts	Brake caliper right new	1
B1BTRL	Bremssattel neu links	Brake caliper left new	1
B2ATR	Bremszangenkolben	Caliper piston	4
B3ATR	Rep-Satz Bremssattel (2 Bremssättel)	Caliper repair kit (2 calipers)	1
B5ATR	Satz Bremsklötze (4)	Set brake pads (4)	1
B5BTRCRACE	Satz Bremsklötze für Straße und Rundstrecke	Set brake pads, for street and competition	1
B6ATR	Satz (4) Befestigungsstifte/ Splinte/ Antiquietschplättchen	Set (4) front brake pad pins/shims/clips/ anti-squel kit	1
B9SPT	Entlüftungsniessel alle Bremssättel	Air bleed screw	2
B14AH	Bremsscheibe	Brake disc	2
B15MGC	Befestigungsschraube Bremssattel	Bolt brake caliper	4
B16MGC	Sicherungsblech Bremssattel	Caliper locking tab	2
D57TR	Befestigungsschraube Bremsscheibe	Bolt brake disc	10

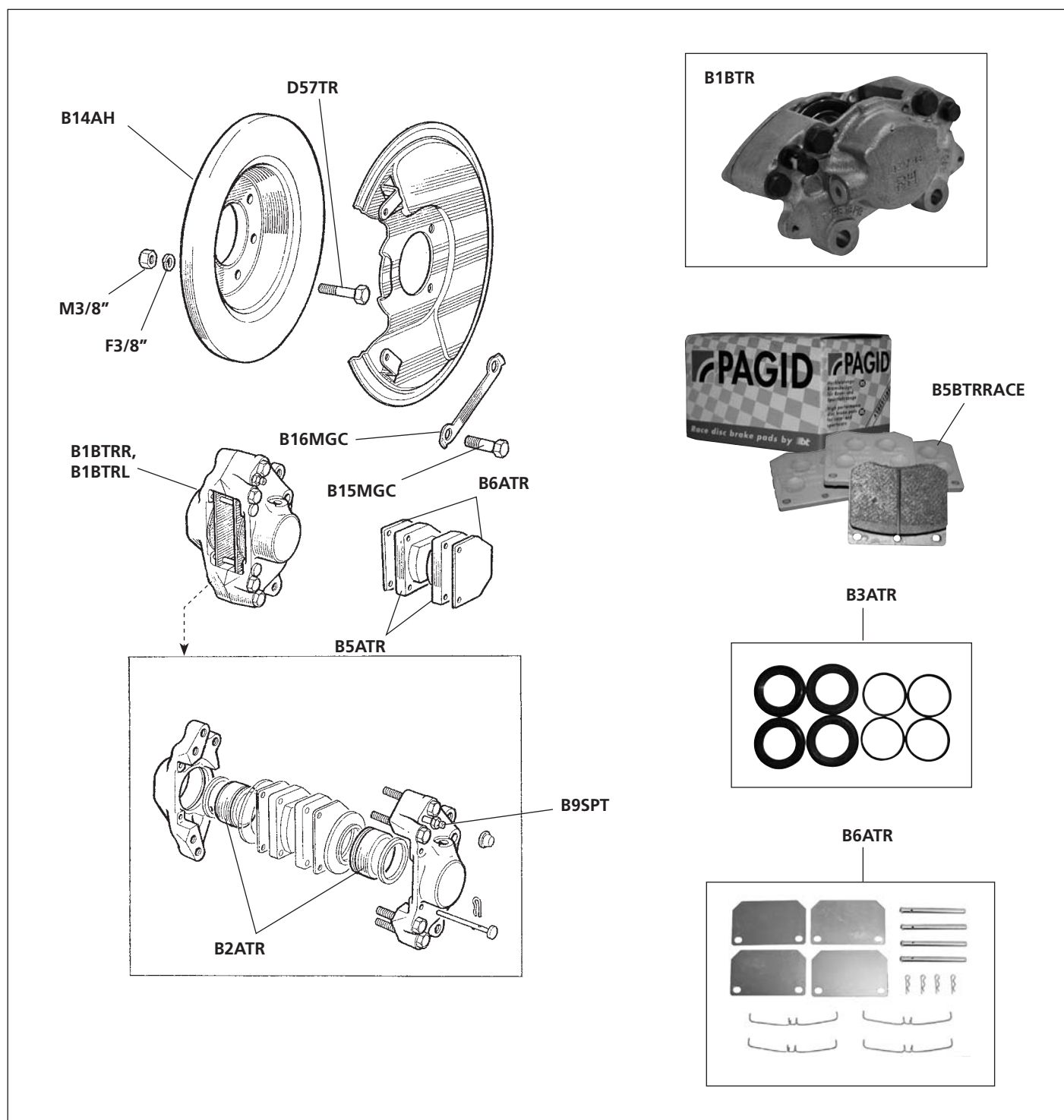

Bremse Hinterachse MGC

Rear brake system MGC

No.	Bezeichnung	Description	Anzahl/Qty.
B18MGC	Staubkappe Handbremshebel	Boot brake drum	2
B20MGC	Führungsplatte Bremsbacken	Support plate	2
B21MGC	Radbremszylinder	Wheel cylinder assembly	2
B22MGC	Rep-Satz Radbremszylinder	Repair kit wheel cylinder	2
B23MGC	Haltestift Bremsbacken	Brake shoe fixing pin	4
B23MGA-21	Stopfen Bremstrommel 1/2"	Plug 1/2", brake drum	2
B24MGC	Haltefeder Bremsbacken	Spring brake shoe retaining	4
B25MGC	Haltescheibe Bremsbacken	Cup washer brake shoe	4
B26MGC	Rückholfeder Bremsbacken (bei Radbremszylinder)	Spring brake shoe retaining (wheel cylinder)	2
B27MGC	Rückholfeder Bremsbacken (bei Bremseinsteller)	Spring brake shoe retaining	2
B30BSPT	Befestigungssatz Radbremszylinder	Plate + spring fitting kit wheel cylinder	1
B42MGA/TC	Mutter 3/8"	Nut 3/8"	4
SR7-3/4"	Senkopfschraube 1/4"x3/4"	Screw 1/4"x3/4"	4

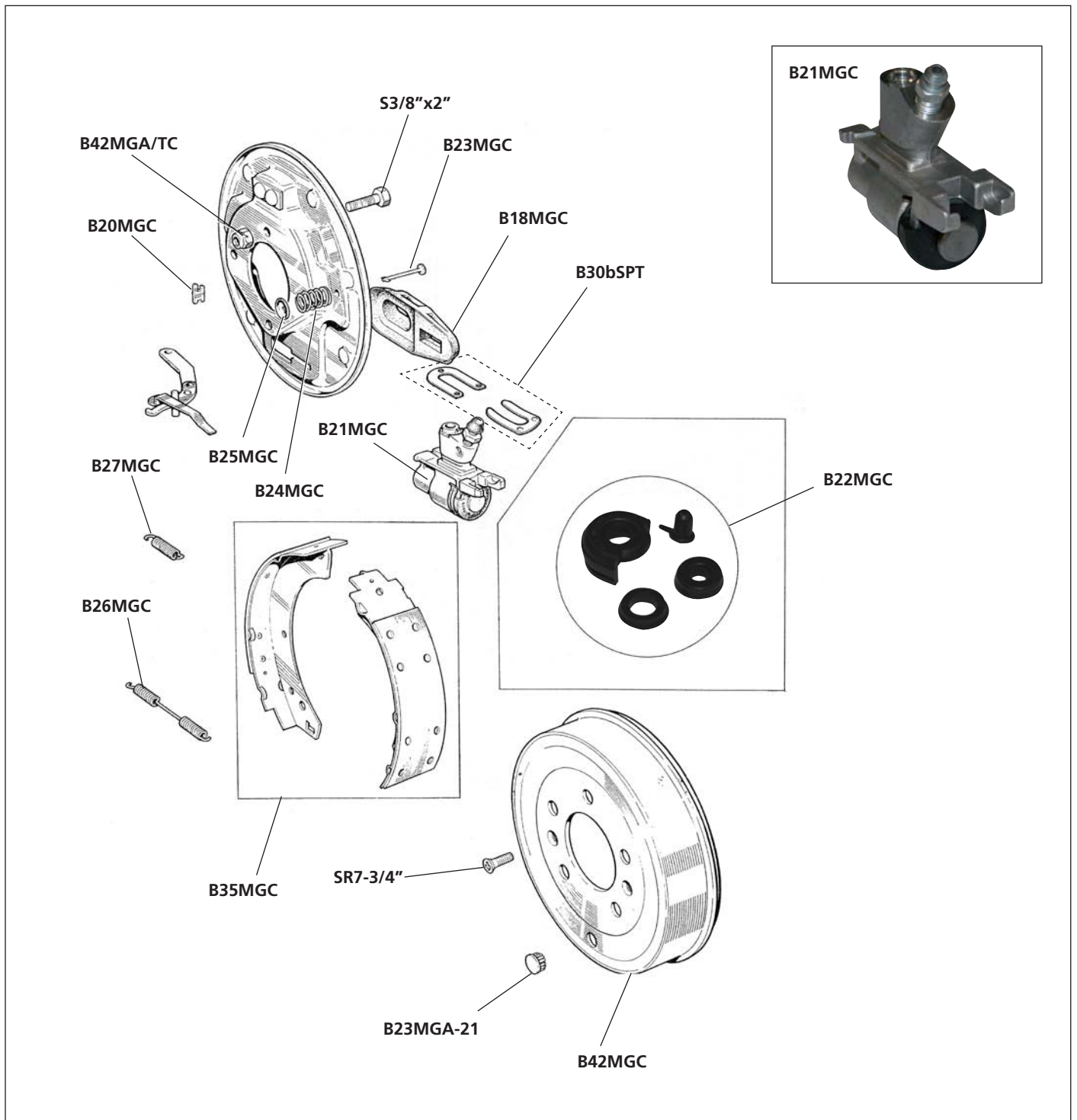

Bremsleitungen / Bremsschläuche MGC

Brake pipes & hoses MGC

No.	Bezeichnung	Description	Anzahl/Qty.
B20MGA-22	Sicherungsblech Bremsleitung	locking plate brake pipe	A/R
B40MGC	Bremsleitungssatz Kunifer 1-Kreis	Brake pipe set single circle kunifer	1
B40MGC/RHD	Bremsleitung-Satz 1-Kreis Rechtslenker	Brake pipe set single circle RHD	1
B56TR	Bremsschlauch Hinterachse	Brake hose rear	1
B56TRAQ	Bremsschlauch stahlummantelt hinten mit TÜV-Gutachten	steel coated brake hose rear with TÜV approval	1
B56ATRAQ	Bremsschlauch stahlummantelt vorne mit TÜV-Gutachten	steel coated brake hose front with TÜV approval	2
B58C	Zahnscheibe	star washer	A/R
B58D	Kupferscheibe Bremsschlauch	copper washer brake hose	A/R
B60SPT1500	Bremsschlauch Vorderachse	brake hose front	2
HM3/8"	Kontermutter Bremsschlauch	Nut brake hose	A/R



Bremskraftverstärker MGC

Brake servo unit MGC

B250AH	Bremskraftverstärker als Ersatz für den/die nicht mehr lieferbaren original Bremskraftverstärker. Halterungen müssen angepasst werden.	Brake servo unit as replacement for the not available OE Brake servo unit. Brakets has to be modified	1/2
B252AH	Rep.-Satz original Bremskraftverstärker Fahrge.-Nr: G-CN1, G-CD1-101 bis 1153 (nicht USA)	Repair kit servo brake unit G-CN1, G-CD1-101 to 1153 (except USA)	1
B252MGC	Rep.-Satz original Bremskraftverstärker Fahrge.-Nr: G-CN1 (nur USA), alle ab G-CD1 ab 1154	Repair kit servo brake unit G-CN1 (only USA), all models from G-CD1 from 1154	1

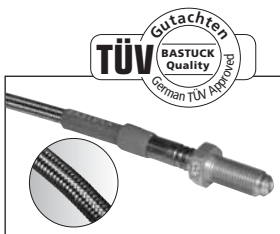
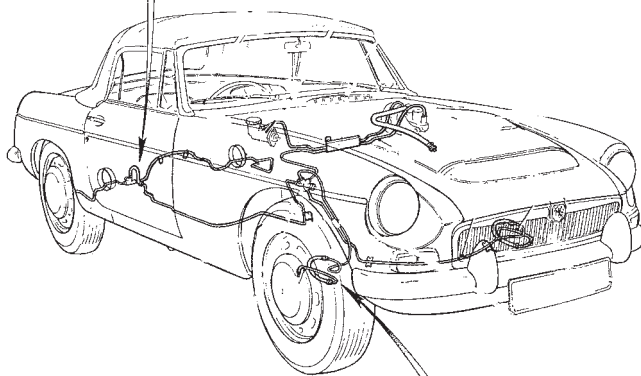
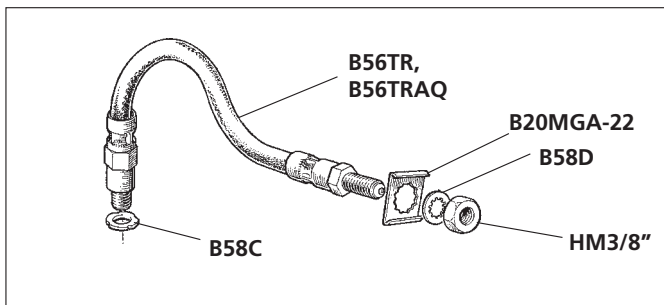

B60SPT1500, B56aTRAQ

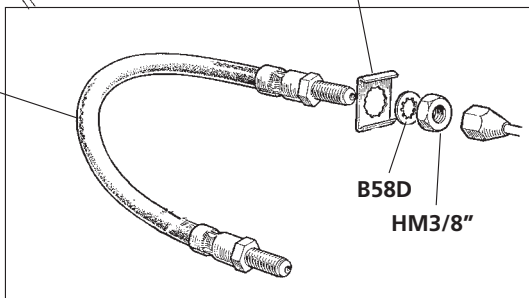

Stahlummantelte Bremsschläuche – mit TÜV-Gutachten!

- Super Optik
- härterer Pedaldruck
- kürzerer Pedalweg

Steel coated brake hoses – with TÜV Approval!

- perfect finish
- improved pedal feeling
- less pedal travel

weitere Teile zu Bremsschläuchen und -leitungen finden Sie auf Seite 80

please refer page 80 for more parts "brake pipes & hoses"

Hauptbremszylinder MGC

Brake master cylinder MGC

No.	Bezeichnung	Description	Anzahl/Qty.
B1MGC	Hauptbremszylinder 1-Kreis für separaten Bremsflüssigkeitsbehälter	Brake master cylinder single line with separate brake fluid tank	1
B1AMGC	Hauptbremszylinder 1-Kreis mit integriertem Bremsflüssigkeitsbehälter	Brake master cylinder single line	1
B1MGC/2K	Hauptbremszylinder 2-Kreis mit separatem Bremsflüssigkeitsbehälter	Brake master cylinder double line with separate brake fluid tank	1
B1AMGC/2K	Hauptbremszylinder 2-Kreis mit montiertem Bremsflüssigkeitsbehälter	Brake master cylinder double line	1
B2MGC	Reparatursatz für 1-Kreis Hauptbremszylinder	Repair kit for single line brake master cylinder	1
B2MGC/2K	Reparatursatz 2-Kreis Hauptbremszylinder	Repair kit for double line brake master cylinder	1
B4MGC	Bremsflüssigkeitsbehälter für B1MGC	Brake fluid tank for B1MGC	1
B12MGC	Stehbolzen 5/16" UNF	Stud 5/16" UNF	2
S3/16" X5/8" LK	Linsenkopf-Schraube UNF 3/16 x 5/8"	Screw 3/16" x5/8" UNF	1
S3/16" X1/2" RK	Rundkopf-Schraube UNF 3/16 x 1/2" (12,7m Gewindelänge)	Screw 3/16" x1/2" UNF	1

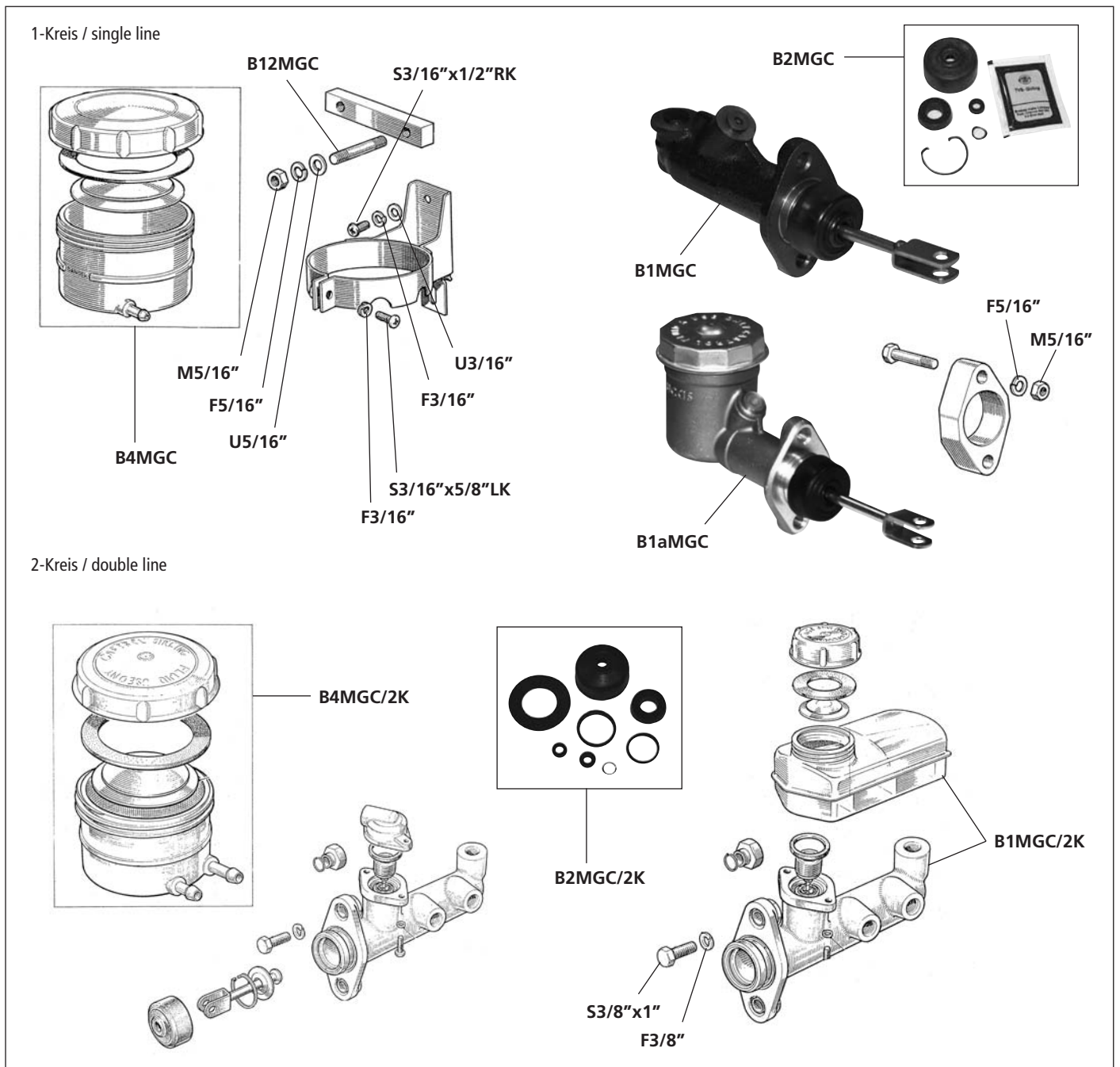

No.	Bezeichnung	Description
EM09MGA-50	Aufkleber „Safety Fast“ (Innenseite Frontscheibe)	Sticker „safety fast“ frontscreen (inner)
EM10MGA-50	Aufkleber „Safety Fast“ (außen)	Sticker „safety fast“ (body)
EM11MGA-50	Aufkleber „Special Tuning“ (außen)	Sticker „special tuning“ (body)
EM20MGA-50	Schlüsselanhänger mit -MG-Emblem schwarz	Key fob -MG- octagon black
EM21MGA-50	Schlüsselanhänger mit -MG-Emblem rot	Key fob -MG- octagon red
EM22MGA-50	Schlüsselanhänger mit „Union-Jack“-Emblem	Key fob „Union Jack“ flag
EM32SPT	Union Jack-Fahne Emailliert, klein (5 X 2,5 cm)	Union Jack enamel badge (5 x 2,5 cm)
EM33SPT	Aufkleber Union Jack-Fahne (7,5 X 4,5 cm)	Union Jack self-adhesive (7,5 x 4,5 cm)
S34MGA-19	Original-Schaltknopf	Original gear lever knob
S35MGA-19	Holzschaltknopf mit -MG-Emblem (Kunststoff-Einsatz)	Wooden gear knob -mg- logo (nylon thread insert)
S36MGA-19	Lederschaltknopf mit -MG-Emblem (Kunststoff-Einsatz)	Leather gear knob -MG- logo (nylon thread insert)
S24MGA-19	Holzschaltknopf mit -MG-Emblem (Metall-Innengewinde)	Wooden gear knob -mg- logo (metal thread insert)
S38AMGB-27	Zierblende Schweller mit Logo	Sill plate with logo
	Hochwertige Staubschutzabdeckung mit MG-Logo, atmungsaktiv, vliesähnlicher Innenstoff für optimalen Lackschutz, mit Stautasche:	Top quality dust protection car cover with MG-logo, breathability, soft lining comparable to fleece, car cover comes with bag:
i15MGB/B	für MGB Roadster, Abdeckung in blau	car cover blue, for MGB Roadster models
i15MGB/G	für MGB Roadster, Abdeckung in grün	car cover green, for MGB Roadster models
i15MGB-GT/B	für MGB GT, Abdeckung in blau	car cover blue, for MGB GT models
i15MGB-GT/G	für MGB GT, Abdeckung in grün	car cover green, for MGB GT models
WZ70MG	Werkstattschürze mit MG-Emblem	Shop apron with MG-logo
WZ80MG	Montageschutz zum Auflegen an Kotflügel	Wing protector, MG-logo
EM100MG	Pin MG rot/gold	Pin MG red/gold
EM101MG	Pin MG schwarz/weiß	Pin MG black/white
EM105MGB/GTROT	Pin MGB GT rot	Pin MGB GT red
EM105MGB/GTSCHWARZ	Pin MGB GT schwarz	Pin MGB GT black
EM105MGB/GTBLAU	Pin MGB GT blau	Pin MGB GT blue
EM105MGB/GTGRUEN	Pin MGB GT grün	Pin MGB GT green
EM105MGB/GTWEISS	Pin MGB GT weiß	Pin MGB GT white
EM105MGBROT	Pin MGB Roadster rot	Pin MGB Roadster red
EM105MGBSCHWARZ	Pin MGB Roadster schwarz	Pin MGB Roadster black
EM105MGBBLAU	Pin MGB Roadster blau	Pin MGB Roadster blue
EM105MGBGRUEN	Pin MGB Roadster grün	Pin MGB Roadster green
EM105MGBWEISS	Pin MGB Roadster weiß	Pin MGB Roadster white
EM140MG/S-R	Aufnäher MG schwarz/rot	Patch MG black/red
EM141MG/W-R	Aufnäher MG weiß/rot	Patch MG white/red
EM145MG	Lesezeichen MG schwarz/weiß	Bookmarker MG black/white
EM160MGB	Maus-Pad MGB Roadster	Mouse pad MGB Roadster

Radio Retro Style – modernste Technik im klassischen Design

– auch für den externen Anschluss digitaler Musikquellen

– modern sound for your classic car with aux input for digital playback possibilities

- mit Uhr
- Eingang:
- USB,
- SD-Karte
- 2x AUX 3,5 mm Klinke
- radio with clock
- connecting inputs:
- USB,
- SD-card
- 2x AUX 3,5 mm

No.	Bezeichnung	Description	Anzahl/Req.
E600chrom	Retro Sound „Classic Style“ Auto Radio Front chrom ohne Blende	Retro Sound „Classic Style“ Auto Radio chrome w/o cover	1
E600schwarz	Retro Sound „Classic Style“ Auto Radio Front schwarz ohne Blende	Retro Sound „Classic Style“ Auto Radio black w/o cover	1
E610chrom	Radio Blende chrom, mit Knöpfen chrom „Classic Style“ für Art. E600..	radio cover chrome, with chrome knobs „Classic Style“ to art. no. E600..	1
E610schwarz	Radio Blende schwarz, mit Knöpfen schwarz „Classic Style“ für Art. E600..	radio cover black, with black knobs, „Classic Style“ to art. no. E600..	1
E610sch/chrom	Radio Blende schwarz mit Chromrand, mit Knöpfen chrom „Classic Style“ für Art. E600..	radio cover black with chrome line, with chrome knobs „Classic Style“ to art. no. E600..	1

Hinweis: Anschluss nur bei Fahrzeugen mit Minus an Karosserie möglich! / **Note:** Car must be negative ground!



i15MGB..



WZ70MG



WZ80MG



EM11MGA-50



EM20MGA-50



EM21MGA-50



EM32SPT



EM33SPT



S36MGA-19



S35MGA-19,
S24MGA-19



S43MGA-19

EM100MG



EM101MG

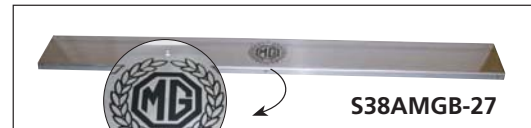

S38AMGB-27



EM105MGB/GT..



EM105MGB..



EM140MG/S-R



EM141MG/W-R

Radio Retro Style



E610..

E600..



EM145MG

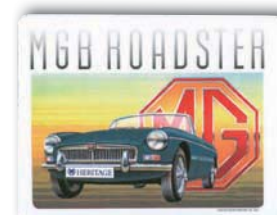

EM160MGB

Original Bedienungsanleitung (engl.)		Original Owners Handbook (engl.)
No.	Bezeichnung	Description
Li08MGA-49	MGA1500	MGA1500
Li09MGA-49	MGA1600	MGA1600
Li10MGA-49	MGA1600 MK2	MGA1600 MK2
Li11MGA-49	MGA Twin-Cam	MGA Twin-Cam
Li01MGB-50	MGB Bj. 1962 bis Bj.1965	MGB 1962-65
Li02MGB-50	MGB Bj. 1967 bis Bj.1976 "Europa"	MGB 1967-76 „Europe“
Li03MGB-50	MGB Bj. 1969 bis Bj.1972 "Europa"	MGB 1969-72 „Europe“
Li04MGB-50	MGB nur Bj. 1969 "Europa"	MGB 1969 „Europe“
Li05MGB-50	MGB Bj. 1968 bis Bj.1969 "USA"	MGB US 1968-69
Li07MGB-50	MGB Bj. 1972 "USA"	MGB US 1972
Li08MGB-50	MGB Bj. 1973 "USA"	MGB US 1973
Li09MGB-50	MGB Bj. 1974 "USA"	MGB US 1974
Li10MGB-50	MGB Bj. 1975 bis Bj. 1976 "USA"	MGB US to 1976
Li12MGB-50	MGB Bj. 1978 "USA"	MGB US 1978
Li13MGB-50	MGB Bj. 1979 "USA"	MGB US 1979

Original Bedienungsanleitung (deutsch.)		Original Owners Handbook (german)
Li50MGA	MGA 1500/1600/1622	MGA 1500/1600/1622
Li54MGB	MGB Bj. 1968-73 Roadster GHN4-GHN5, GT GHD4-GHN5	MGB 1968-73 Roadster GHN4-GHN5, GT GHD4-GHN5

Original Ersatzteilkatalog (engl.)		Original Parts Book (engl.)
Li01MGA-49	MGA 1500	MGA 1500
Li02MGA-49	MGA 1600	MGA 1600
Li15MGB-50	MGB bis Bj. 9/1976	MGB up to 1976
Li16MGB-50	MGB ab Bj. 9/1976	MGB from 1976

Original Werkstatthandbuch (engl.)		Original Workshop Manual (engl.)
Li03MGA-49	MGA 1500/1600 (engl.)	MGA 1500/1600 (engl.)
Li05MGA-49	MGA Twin/Cam (engl.)	MGA Twin/Cam (engl.)
Li06MGA-49	MGA/MGB bis 1968 (engl.)	MGA/MGB up to 1968 (engl.)
Li18MGB-50	MGB Bj. 1977 bis Bj.1978 (engl.)	MGB 1977-1978 (engl.)
Li19MGB-50	MGB ab Bj. 1978 (engl.) Taschenbuch-Format	MGB from 1978 (engl.)
Li20MGB-50	MGA/MGB bis Bj.1968 (engl.) Taschenbuch-Format	MGA/MGB up to 1968 (engl.) pocket size
Li21MGB-50	MGB ab Bj.1968 (engl.) Taschenbuch-Format	MGB from 1968 (engl.) pocket size

Original Werkstatthandbuch (deutsch)		Original Workshop Manual (german)
Li17MGA	MGA (deutsch)	MGA (german)
Li17MGB-50	MGB Bj. 1963 bis Bj.1974 (deutsch)	MGB 1963-1974 (german)

MGC Literatur		Literature MGC
Li10MGC	Betriebsanleitung englisch	Owners Handbook engl.
Li15MGC	Ersatzteilkatalog "Power Units" (Motor + Getriebe)	Spare part catalogue "Power Units" (Engine, Gearbox)
Li16MGC	Ersatzteilkatalog "Mechanik" (Achse, Bremsen,...)	Spare part catalogue "mechanical" parts (axle, breaks,...)
Li17MGC	Ersatzteilkatalog "Karosserie" (Blechteile, Elektrik, Chromteile...)	Spare part catalogue "Body" parts (Panel, Chrome, Electrical)
Li18MGC	Werkstatthandbuch englisch	Workshop manual engl.

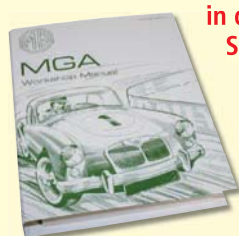

MGA Li17MGA

in deutscher
Sprache!

MGB Roadster + GT
Li17MGB-50MGA
Li50MGA

in deutscher Sprache!

MGB Roadster + GT

Sonstige Literatur (in engl. Sprache)

Other Literature (english)

No.	Bezeichnung	Description
Li12MGA-49	„MGA special tuning“ Buch (engl.)	Book „MGA special tuning“ (engl.)
Li13MGA-49	SU Carburettors „Haynes“ (engl.)	SU Carburettors „Haynes“ (engl.)
Li14MGA-49	Weber Carburettors „Haynes“ (engl.)	Weber Carburettors „Haynes“ (engl.)
Li15MGA	Weber Carburettor Manual „Haynes TechBook“ (engl.)	Weber Carburettor Manual „Haynes TechBook“ (engl.)
Li40MGB-50	Tuning Handbuch MGB 1962-1967 rot	Tuning Handbook MGB 1962-1967 red
Li41MGB-50	Tuning Handbuch MGB 1968-1980 blau	Tuning Handbook MGB 1968-1980 blue
Li48MGB-50	Workshop Manual MGB Haynes *	Workshop manual MGB Haynes
Li49MGB-50	Workshop Manual MGA Haynes *	Workshop manual MGA Haynes

* Werkstatthandbücher mit detaillierten Beschreibungen, Abbildungen, Tipps und Anweisungen

(in deutscher Sprache)

(german)

Li13D	SU-Vergaser Praxishandbuch	SU-Carburettors practical guide
Li14D	Weber & Dellorto Querstromvergaser	Weber & Dellorto Carburettors
Li81MGA	„Das Original MGA“ by Clausager, Heel	Original MGA by Clausager, Heel
Li81MGB	„Das Original MGB, MGC, V8“ by Clausager, Heel	Original MGB, MGC, V8 by Clausager, Heel

Li01MGA-49	Li01MGB-50	Li02MGA-49	Li02MGB-50	Li03MGA-49	Li08MGA-49	Li10MGA-49
Li10MGB-50	Li10MGC	Li11MGA-49	Li12MGA-49	Li13D	Li13MGA-49	Li14D
Li14MGA-49	Li15MGA	Li15MGC	Li16MGC	Li17MGC	Li17MGB-50	Li18MGC
Li20MGB-50	Li21MGB-50	Li41MGB-50	Li54MGB	Li81MGA	Li81MGB	

Steckschlüssel (Nüsse) - 1/2" Antrieb / Socket wrench inserts 1/2" drive

No.	Größe / Dimension	No.	Größe / Dimension
WZ5	7/16"	WZ13	25/32"
WZ6	1/2"	WZ14	13/16"
WZ7	9/16"	WZ15	7/8"
WZ8	19/32"	WZ16	15/16"
WZ9	5/8"	WZ17	31/32"
WZ10	21/32"	WZ18	1"
WZ11	11/16"	WZ18a	1 1/8"
WZ12	3/4"		

Ring/Gabelschlüssel / Ring- / flat wrenches

No.	Größe / Dimension	No.	Größe / Dimension
WZ19	7/16"	WZ24	3/4"
WZ20	1/2"	WZ25	13/16"
WZ21	9/16"	WZ26	7/8"
WZ22	5/8"	WZ27	15/16"
WZ23	11/16"	WZ28	1"

No.	Bezeichnung	Description
WZ2	Steckschlüssel-Satz 12-tlg.	Socket wrench 12-pieces
WZ3	Ring/Gabelschlüssel-Satz, 9-tlg (Schlüssel 3/8" bis 3/4")	Ring- / flat wrench set, 9 pcs. (dimension 3/8" to 3/4")
WZ4	Inbusschlüssel-Satz	Hexagon wrench set
WZ40	Inbusschlüssel 3/16"	Hexagon wrench set 3/16"
WZ04MGA-53	Zoll-Fühlerlehre (0.0015" - 0.0025")	Feeler gauge (0.0015" - 0.0025")
WZ16MGA-53	Einstellschlüssel SU-Vergaser	Adjusting tool SU-carburettor
WZ19MGA-53	Fettpresse, klein	Grease gum, small
WZ50/UNC	Hochwertiger Gewindegewinde-schneider Satz 1/8" - 1/2" im Holzkoffer:	Taps & Dies set 1/8" - 1/2" high quality tool in wooden box:
WZ50/UNF	für Grobgewinde UNC	for UNC
WZ55	für Feingewinde UNF	for UNF
WZ55	Magnetische Schale	Magnetic tray
WZ101	Einstellschlüssel für Einstell-exzenter Bremse, Schlüsselweite 1/4" + 5/16"	Tool for wheel cylinder adjuster, dimension 1/4" + 5/16"

No.	Bezeichnung	Description
MD17SPT	Dauerplast. Universaldichtung „Marston“ 80 ml	Universal jointing compound „Marston“ 80 ml
MD17ASPT	Hochwertige Silikondichtmasse - schwarz „Hylasil“ 200 ml	Silicone sealant - black „Hylasil“ 200 ml
MD20/HF	Schrauben Sicherung „hochfest“ 50 ml Flasche	„Stud lock“ - 50 ml high strenght
MD20/MF	Schrauben Sicherung „mittelfest“ 50 ml Flasche	„Stud lock“ - 50 ml medium strenght
MD21/HF	Buchsen-und Lagerbefestigung 50 ml Flasche „hochfest“	„Bush & Bearing lock“ 50 ml high strenght

Wir vertreiben ausschließlich hochwertiges Qualitätswerkzeug von führenden Herstellern (FACOM, HAZET, Stahlwille usw.) mit lebenslanger Garantie bei sachgemäßer Handhabung.

We sell only high-quality tools made by the leading manufacturers (FACOM, HAZET, Stahlwille etc..) with lifetime warranty if properly used.



RAVENOL®



RV3010-5

RV3010-1



RV3004



RV3009

RV3030

RV3031

RV3033

RV3034



RV4608 7

RV4608 3



RV2004



RV3005



RV4617 0



RV4605 3



IUC



RV3002



RV3059



RV3057



RV3025

RAVENOL Pumpflaschen / RAVENOL pump aerosol 500 ml

No.	Bezeichnung	Description
RV3002	Kaltreiniger (lösemittelfrei) zur hochwirksamen Reinigung von Motor- und Maschinenteilen, lackierten und Kunststoffteilen, Fliesen uvm.	Cleaner of all kind of engines, mechanical parts. It quickly penetrates grease, dirt, oil and grime, and swiftly removes contaminants. Product w/o solvent
RV3004	Teerentferner bei Teer- und Ölverschmutzungen auf Chrom und Lack	Cleaner of tar and fats from car lacquers and chrome
RV3025	Glasklar - ideal für alle Glas- und Spiegelflächen innen und außen	Cleaner for all kinds of car glass, mirrors and other hard, glossy surfaces
RV3057	Felgen-Reiniger zur Reinigung von Stahlfelgen, Rahmen, Motor-teilen uvm.	Cleaner of steel wheels, car chassis, engine parts ..
RV3059	Insektenentferner auf Glas-, Lack-, Chrom- und Kunststoff-flächen	Cleaner of dirt, insects and bird droppings from car lacquer, polish chrome and metall surfaces

RAVENOL Spraydosen / RAVENOL aerosol can 400 ml

RV3009	Rostlöser mit MoS ₂ , bei festgefressenen Schrauben, Quietsch- und Knarrgeräuschen	Effective remedy for rusted and corroded parts and threads, eliminating squeaks, contains MoS ₂
RV3030	Bremsenreiniger für Bremsen- und Kupplungsteile	Brake cleaner for brake and clutch parts
RV3031	Cockpit-Spray zur Reinigung und Pflege von Kunststoff, Kunst- und Naturleder	Cockpit panel cleaner, restores, penetrates and protects all plastic, vinyl and plexiglas surfaces
RV3033	Silikon Spray für die Gummi- und Kunststoffpflege	Silikon spray lubricant. Used for plastics and rubber.
RV3034	Motorstarter für alle Benzin- und Dieselmotoren geeignet	Motor Starter. For petrol and Diesel engines.

Diverses / Divers

RV3005	Autoshampoo - reinigungsintensiv, umweltschonend, 1 Liter	Universal concentrated liquid detergent excellent for thoroughly cleaning cars, 1 liter
RV3010-1	Destilliertes Wasser - entionisiert für Fahrzeugbatterien, Dampf-bügeleisen, Aquarien, 1 Liter	Special water for antifreeze, dilution and use in accumulators, 1 liter
RV3010-5	Destilliertes Wasser, 5 Liter	Special water (like above) 5 liters
RV4605 3	Messkanne, 1 Liter	Pot, 1 liter
RV4608 3	Trichter Ø 100 mm	Funnel Ø 100 mm
RV4608 7	Trichter Ø 250 mm	Funnel Ø 250 mm
RV4617 0	Mehrzweckkanne, 7 Liter	Pot, universal, 7 liters
RV2004	Super EP-Langzeitfett, für Gleit- und Wälzlager, 400 gr. Patrone	Super EP Long-life grease for all plain and rolling bearings subjected to heavy loads, cartridge 400 g.
IUC	BASTUCK Inox-Ultra-Clean, Edelstahl- und Chromreiniger, 250 ml	BASTUCK Inox-Ultra-Clean, for stainless steel and chrome parts, 250 ml

Umrechnungstabelle / Conversion Table

Zoll / Inch	1/4"	5/16"	3/8"	7/16"	1/2"	9/16"	5/8"	3/4"	7/8"	1"
Milli- meter	6,35	7,94	9,53	11,12	12,70	14,29	15,88	19,05	22,23	25,40

Zuordnungsübersicht

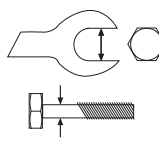

Schlüsselweite (Kopf- größe) / Dimen- sion	7/16"	1/2"	9/16"	5/8"	3/4"
= Schaft-Ø / Shaft Ø	1/4"	5/16"	3/8"	7/16"	1/2"

Muttern und Unterlegscheiben / Nuts & washers

Innen-Ø / Inner diameter	Mutter / Nut UNF, UNC	1/2 Mutter / 1/2 nut UNF	Selbstsichernde Mutter / Stop nut UNF	Unterlegscheibe / Washer plain	Zahnscheibe / Washer star	Federring / Washer spring	Karoseriescheibe / Washer reinforcing
3/16"	Art.-Nr. / Part No : M3/16"		M3/16"S	U3/16"	Z3/16"	F3/16"	K3/16"
1/4"	Art.-Nr. / Part No : M1/4"	HM1/4"S	M1/4"S	U1/4"	Z1/4"	F1/4"	K1/4"
5/16"	Art.-Nr. / Part No : M5/16"	HM5/16"S	M5/16"S	U5/16"	Z5/16"	F5/16"	K5/16"
3/8"	Art.-Nr. / Part No : M3/8"	HM3/8"S	M3/8"S	U3/8"	Z3/8"	F3/8"	K3/8"
7/16"	Art.-Nr. / Part No : M7/16"	HM7/16"S	M7/16"S	U7/16"	Z7/16"	F7/16"	
1/2"	Art.-Nr. / Part No : M1/2"	HM1/2"S	M1/2"S	U1/2"	Z1/2"	F1/2"	
9/16"	Art.-Nr. / Part No : M9/16"	HM9/16"S	M9/16"S	U9/16"		F9/16"	
5/8"	Art.-Nr. / Part No : M5/8"	HM5/8"S	M5/8"S	U5/8"		F5/8"	

Schrauben / Bolts

Schaft-Ø / Shaft diam.:	Länge / Length:							
	1/2"	3/4"	1"	1 1/4"	1 1/2"	1 3/4"	2"	2 1/4"
3/16"	Art.-Nr. / Part No : S3/16"x1/2"	S3/16"x3/4"	S3/16"x1"	S3/16"x1 1/4"	S3/16"x1 1/2"			
1/4"	Art.-Nr. / Part No : S1/4"x1/2"	S1/4"x3/4"	S1/4"x1"	S1/4"x1 1/4"	S1/4"x1 1/2"	S1/4"x1 3/4"	S1/4"x2"	
5/16"	Art.-Nr. / Part No : S5/16"x1/2"	S5/16"x3/4"	S5/16"x1"	S5/16"x1 1/4"	S5/16"x1 1/2"	S5/16"x1 3/4"	S5/16"x2"	S5/16"x2 1/4"
3/8"	Art.-Nr. / Part No : S3/8"x1/2"	S3/8"x3/4"	S3/8"x1"	S3/8"x1 1/4"	S3/8"x1 1/2"	S3/8"x1 3/4"	S3/8"x2"	S3/8"x2 1/4"
7/16"	Art.-Nr. / Part No :		S7/16"x1"	S7/16"x1 1/4"	S7/16"x1 1/2"	S7/16"x1 3/4"	S7/16"x2"	S7/16"x2 1/4"
1/2"	Art.-Nr. / Part No :				S1/2"x1 1/2"	S1/2"x1 3/4"	S1/2"x2"	S1/2"x2 1/4"
Schaft-Ø / Shaft diam.:	2 1/2"	2 3/4"	3"	3 1/4"	3 1/2"	4"	4 1/4"	4 1/2"
1/4"	Art.-Nr. / Part No : S1/4"x2 1/2"							
5/16"	Art.-Nr. / Part No : S5/16"x2 1/2"	S5/16"x2 3/4"	S5/16"x3"	S5/16"x3 1/4"	S5/16"x3 1/2"			
3/8"	Art.-Nr. / Part No : S3/8"x2 1/2"	S3/8"x2 3/4"	S3/8"x3"	S3/8"x3 1/4"	S3/8"x3 1/2"			
7/16"	Art.-Nr. / Part No : S7/16"x2 1/2"	S7/16"x2 3/4"	S7/16"x3"	S7/16"x3 1/4"	S7/16"x3 1/2"	S7/16"x4"		
1/2"	Art.-Nr. / Part No : S1/2"x2 1/2"	S1/2"x2 3/4"		S1/2"x3 1/4"		S1/2"x4"		
9/16"	Art.-Nr. / Part No :						S9/16"x4 1/4"	S9/16"x4 1/2"

Sonstiges / Divers

No.	Bezeichnung	Description
SR1	Sechskant-Blechschaube 6,5 x 20 mm	hexagon palte screw 6,5 x 20 mm
SR2	Blechmutter für SR1 - 6,5 mm	plate nut for SR1
SR3	Rundkopf-Blechschaube 6,3 x 22	binding screw 6,3 x 22
SR4	Rundkopfschraube 1/4"x1" UNF	binding screw 1/4"x1" UNF
SR7	Senkkopfschraube 1/4"x1/2" UNF	countersunk screw 1/4"x1/2" UNF
SR7-3/4"	Senkkopfschraube 1/4"x3/4" UNF	countersunk screw 1/4"x3/4" UNF
SR7-1 3/4"	Senkkopfschraube 1/4"x1 3/4" UNF	countersunk screw 1/4"x1 3/4" UNF
SR8	Senkkopfschraube 1/4"x1" UNF	countersunk screw 1/4"x1" UNF
SR9	Senkkopfschraube 5/16"x1" UNF	countersunk screw 5/16"x1" UNF
SR10	Inbusschraube 1/4"x3/4" UNF	inbus screw 1/4"x3/4" UNF
SR11	Sechskant-Blechschaube 5,5 x 15 mm	hexagon palte screw 5,5 x 15 mm
SR12	Blechmutter 5,5 mm für SR11	plate nut 5,5 mm for SR11
SR13	Senkkopfschraube 3/16"x3/4"	countersunk screw 3/16"x3/4"
SR14	Linsenkopfschraube 3/16"x3/4"	mushroom headed screw 3/16"x3/4"
SR50	Splint 1,5 mm	split pin 1,5 mm
SR51	Splint 2,5 mm	split pin 2,5 mm
SR52	Splint 3,2 mm	split pin 3,2 mm
SR60	Kupferdichtring - 1/4" Innendurchmesser	copper washer - 1/4" inner diameter
SR61	Kupferdichtring - 5/16" Innendurchmesser	copper washer - 5/16" inner diameter
SR62	Kupferdichtring - 3/8" Innendurchmesser	copper washer - 3/8" inner diameter
SR64	Kupferdichtring - 1/2" Innendurchmesser	copper washer - 1/2" inner diameter

MGB Seriennummern / Location of Unit Numbers

Die Fahrgestellnummer ist auf einem Schild auf der linken Kotflügelwand vor dem Kühler eingeschlagen /
The car number is stamped on a plate secured to the left-hand wing valance forward of the radiator.

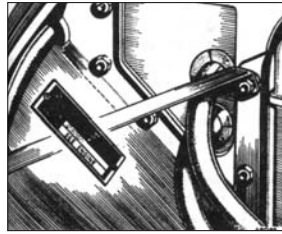

Die Karosserienummer ist auf einem Schild am rechten Frontblech hinter dem Kühlerstehtblech eingeschlagen /
The body number is stamped on a plate secured to the right hand front valance behind the radiator diaphragm.

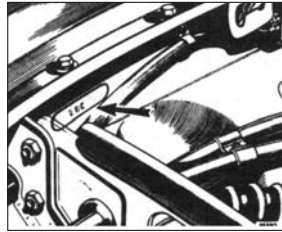

Die Motornummer ist auf einem Schild auf der rechten Seite des Motorblocks eingeschlagen /
The engine number is stamped on a plate secured to the right-hand side of the cylinder block.

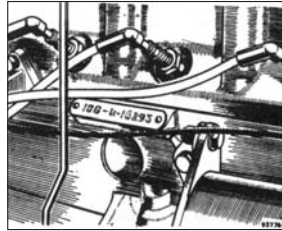

Die Getriebenummer ist am Getriebegehäuse neben dem Ölmeßstab eingeschlagen /
The gearbox number is stamped on the top of the gearbox casing adjacent to the dipstick.

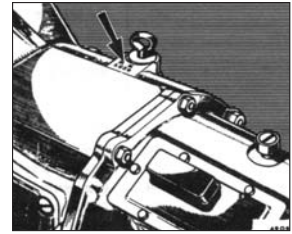

Die Nummer der Overdrive-Einheit befindet sich an der seitlichen Solenoid-Abdeckung an der rechten Seite der Einheit /
The overdrive unit number is stamped on the solenoid side cover on the right-hand side of the unit.

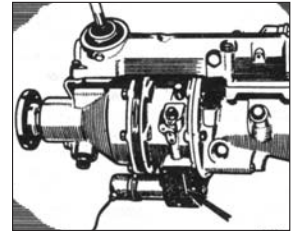

Die Hinterachsnummer ist an der linken Vorderseite des Achsrohrs in der Nähe der Blattfeder-Platte eingeschlagen /
The rear axle number is stamped on the front of the axle tube on the left-hand side adjacent to the spring seat

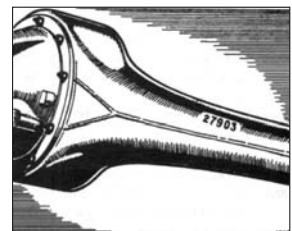

MGB Roadster Identifikation / MGB Roadster Identification Data

Modell / Model		ab / Commencing	bis / Finishing
MGB Roadster (G-HN3)	Motor Nr. / Engine No.]	18G/U/101 18GA/U/101 18GB/*101	18G/U/31121 18GA/U/17500 18GB/*91200
	Fahrgst. Nr. / Car No.	G-HN3-101	G-HN3-138400
	Kaross.Nr. / Body No.	MGB 101	MGB 100292
MGB Roadster (G-HN4)	Motor Nr. / Engine No.] (USA)	18GD/*101 18GG/*101 18GF/*101 18GH/*101	18GD/*7000 18GG/*8700 18GF/*13650 18GH/*22208
	Fahrgst. Nr. / Car No.	G-HN4-13840	G-HN4-187210
	Commission No.	G23N-101F	G23N-28506F
	Commission No. (USA)	GU23N-101F	GU23N-28926F
	Kaross.Nr. / Body No.	MGB-110401	MGB-115519
MGB Roadster (G-HN5)	Motor Nr. / Engine No.] (USA)	18GG/*8701 18GH/*22209 18GJ/*22647 ab/from 18V/*101	n.a. n.a. n.a.
	Fahrgst. Nr. / Car No.	G-HN5-187211	
	Commission No.	G-23N-28507F	
	Commission No. (USA)	GU-23N-28927F	
	Kaross.Nr. / Body No.] (außer/except USA)	MGB-115520	MGB120000
	(außer/except USA + Sweden)	MGB-120001	
	(USA)	MGB-U-23185	
(Sweden)	GBSN-004001		

* Motorcode-Nummer hier eingeschlagen / Engine code No. inserted here

MGB GT (nicht V8) Identifikation / MGB GT (not V8) Identification Data

Modell / Model		ab / Commencing	bis / Finishing
MGB GT (G-HD3)	Motor Nr. / Engine No.	18GB/*101	18GB/*91200
	Fahrgst. Nr. / Car No.	G-HD3-71933	G-HD3-139471
	Kaross.Nr. / Body No.	GBD-101	GBD-21777
MGB GT (G-HD4)	Motor Nr. / Engine No.] (USA)	18GD/*101 18GG/*101 18GF/*101 18GH/*101	18GD/*7000 18GG/*8482 18GF/*13650 18GH/*20289
	Fahrgst. Nr. / Car No.	G-HD4-139472	G-HD4-187840
	Commission No.	G23D-101P	G23D-17179P
	Commission No. (USA)	GU23D-101P	GU23D-17190P
	Kaross.Nr. / Body No.	GBD-22001	
MGB GT (G-HD5)	Motor Nr. / Engine No.] (USA)	18GG/*8483 18GH/*20290 18GJ/*12647 ab/from 18V/*101	n.a. n.a. n.a.
	Fahrgst. Nr. / Car No.	G-HD5-187841	
	Commission No.	G-23D-17180Z	
	Commission No. (USA)	G-23D-17191Z	
	Kaross.Nr. / Body No.] (außer/except USA)	GBD-29008	GBD-040000
	(außer/except USA + Sweden)	GBD-040001	
	(USA)	GBUD-510523	
(Sweden)	GBSD-000301		

* Motorcode-Nummer hier eingeschlagen / Engine code No. inserted here

Identifikation Motorisierung - Motor-Nr.-Schlüssel (nicht V8) / Power Unit Identification - Serial Number Prefix Code (not V8)

Die Motornummerbezeichnung beinhaltet eine Reihe an Zahlen und Buchstaben, die Informationen geben über den Hubraum, Verdichtung, Zusatzausstattung ..	<i>The engine number prefix comprises a series of letters and numbers, presenting in code the cubic capacity, make, the ancillaries fitted and the compression.</i>
1ste Präfix Gruppe – Hubraum, Marke & Typ 1ste Präfix Nummer: 18 = 1800 ccm 1ster Präfix Buchstabe: G = MG or V = längs eingeb.	1st Prefix Group – Cubic capacity, make & type 1st Prefix Number: 18 = 1800 ccm 1st Prefix Letter: G = MG or V = Vertical Line
2 te Präfix Gruppe – Schaltung und Zusatzausstattung Buchstabe U = Manuelle Schaltung R = Overdrive RC = Automatik RWC = Man. Schaltung mit Overdrive, Schaltmechanismus mittig oder Nummer 581 F Präfix Buchstabe Präfix Nummer weitere Präfix-Erläuterungen s. nächste Darstellung	2nd Prefix Group – Gearbox and Ancillaries Letter U = Centre gear change R = Overdrive RC = Automatic RWC = Centre gear change with overdrive or Number 581 F Prefix Letter Prefix Number for a fuller list of prefix no. and their breakdown see next image
3 te Präfix Gruppe – Verdichtung und Seriennummer H = Hoch verdichtet + Seriennummer L = Niedrig verdichtet + Seriennummer	3rd Prefix Group – Compression and serial number H = High compression + Serial No. L = Low compression + Serial No.
Code Beispiel 18G/ U/ H 101 — Seriennummer Hoch verdichtet Man. Schaltung 1800 ccm MG 18V/ 581F/ L 101 — Seriennummer Niedrig verdichtet über Vergaser entlüftetes Kurbelgehäuse und Doppelvergaser Bf Pf We Man. Schaltung, Schaltmechanismus mittig, 1.Gang synchronisiert Drehstrom-Lichtmasch. Schubtriebsstarter 1800 ccm Vertical (in Reihe)	Code Example 18G/ U/ H 101 — Serial Number High Compression Centre gear change 1800 cc MG 18V/ 581F/ L 101 — Serial Number Low Compression Carburettor crank-case ventilation and twin cabs Bf Pf We Centre gear change - all synchromesh Alternator Pre-engaged starter 1800 ccm Vertical (in line)

Bei Motor-Seriennummern immer diese Präfixes verwenden / Always quote these prefixes with engine serial numbers

Fahrzeug-Identifikation - Fgkst.-Nr.-Schlüssel (nicht V8) / Vehicle Identification (not V8) - Serial Number Prefix Letter Code

Die Fahrgestellnummer setzt sich aus einer Reihe an Informationen zusammen mit Angaben über Marke, Motortyp und Baureihe	<i>The car number prefix comprises a series of letters and numbers presenting in code the make, engine type and series.</i>
1ster Präfix Buchstabe G = MG Markenname	1st Prefix Letter G = MG Make Name
2ter Präfix Buchstabe H = Motortyp	2nd Prefix Letter H = Engine Type
3ter Präfix Buchstabe: Karosserieart N = 2-Sitzer Roadster D = Coupé oder GT	3rd Prefix Letter: Body Type N = 2-seater Roadster D = Coupe or GT
4te Präfix 3 = 3. Baureihe 4 = 4. Baureihe 5 = 5. Baureihe	4th Prefix 3 = 3 series 4 = 4th series 5 = 5th series
5te Präfix L = LHD linksgesteuert U = USA Modelle	5th Prefix L = LHD U = USA
6te Präfix: Modelljahr A = 1970 D = 1973 B = 1971 E = 1974 C = 1972	6th Prefix: Model Year A = 1970 D = 1973 B = 1971 E = 1974 C = 1972
Code Beispiel G - H N 3 L — Seriennummer LHD 3. Baureihe Roadster 'B' Motor MG	Code Example G - H N 3 L — Serial number LHD 3rd series Roadster 'B' type engine MG
G - H D 5 U D — Seriennummer 1973 USA 5. Baureihe GT 'B' Motor MG	G - H D 5 U D — Serial number 1973 USA 5th series GT 'B' type engine MG

Bei Fahrgestellnummern immer diese Präfixes verwenden / Always quote these prefixes with engine serial numbers

Fahrzeug-Identifizierung (VIN) - ab Fgst.Nr. 501001 / Vehicle Identification Numbering (VIN) - from no. 501001 onwards

Ab Einführung des 1980 Modelljahres ersetzt das VIN (Vehicle Identification Numbering) - System den früheren Fahrgestellschlüssel / The VIN system replaced the earlier car numbering system from the introduction of the 1980 model year.

1ste & 2te Präfix Buchstaben (Marke + Modell) GV = MGB	5ter Präfix Buchstaben (Motor) J = 1800 ccm
3ter Präfix Buchstaben (Ausführung) A = Grundmodell G = GT J = Japanese L = Canadian V = North America Z = California	7te Präfix Nummer (Modellwechsel) A = 1980 Modelljahr
	6te Präfix Nummer (Schaltung und Lenkung) 1 = Manuelle 4-Gang Schaltung, Rechtslenker RHD 2 = Manuelle 4-Gang Schaltung, Linkslenker LHD
4ter Präfix Buchstaben (Karosserie) D = 2-türiger Sportwagen, offen E = 2-türiger Sportwagen, geschlossen	8te Präfix Nummer (Fertigungsstätte) G = Abingdon

1st & 2nd Prefix Letter (Marque + Model) GV = MGB	5ter Prefix Letter (Engine) J = 1800 cc
3rd Prefix Letter (Class) A = Basis Line G = GT J = Japanese L = Canadian V = North America Z = California	7te Prefix Number (Model Change) A = 1980 Model Year
	6te Prefix Number (Transmission + Steering) 1 = Manual 4 Speed RHD 2 = Manual 4 Speed LHD
4ter Prefix Letter (Body) D = 2 Door Sports Open E = 2 Door Sports Closed	8te Prefix Number (Assembly Plant) G = Abingdon

Demnach handelt es sich bei G V A D J 1 A G - 501001 um einen MGB, für den heimischen Markt spezifiziert, offenes Modell, 1800 ccm, rechtsgelenkt, 1980 Modelljahr / Thus G V A D J 1 A G - 501001 is an MGB Home Market spec, open bodied, 1800cc RHD model.

Wichtige Anzugsdrehmomente / Important torque wrench settings

Radmuttern (Stahlfelge) / Road wheel (Steel wheel)	8,3 - 8,65 mkg
Zylinderkopf / Cylinder head	6,91 mkg
Pleuellagerdeckel / Rod bearing	4,83 mkg
Hauptlagerdeckel / Main bearing	9,7 mkg
Schwungrad an Kurbelwelle / Flywheel crankshaft	5,8 - 6,3 mkg

Einstelldaten Motor / Motor data

Fahrzeug-Modell / Model	Roadster 62-70	Roadster 72-74	Roadster 75-80	GT 67-71	GT 72-74	GT 75-80
Unterbrecherabstand / Contact breaker gap	0,36-0,41 mm	0,36-0,41 mm	0,36-0,41 mm <small>nur / only 1975 & 1976</small>	0,36-0,41 mm	0,36-0,41 mm	0,36-0,41 mm <small>nur / only 1975 & 1976</small>
Zündzeitpunkt v.o.T. / Ignition timing BTDC -statisch / static -dynamisch / dynamic	10° (HC), 8° (LC) 14° @ 600 rpm	1971-72 16° @ 1500 rpm 1973-74 11° @ 1500 rpm	ohne w/o Cat 13° @ 1500 rpm mit w/ Cat 10° @ 1500 rpm	10° (HC), 8° (LC) 14° @ 600 rpm	1971-72 16° @ 1500 rpm 1973-74 11° @ 1500 rpm	ohne w/o Cat 13° @ 1500 rpm mit w/ Cat 10° @ 1500 rpm
Zündfolge / Engine firing order	1-3-4-2	1-3-4-2	1-3-4-2	1-3-4-2	1-3-4-2	1-3-4-2
Zündkerze Elektrodenabstand / Spark plug gap	0,64 mm	0,64 mm	0,9 mm	0,64 mm	0,64 mm	0,9 mm
Leerlaufdrehzahl / Idle speed	500 rpm	850 rpm	850 rpm	500 rpm	850 rpm	850 rpm
Ventilspiel / Valve rocker clearance	0,38 mm kalt / cold	0,38 mm kalt / cold	0,33 mm warm	0,38 mm kalt / cold	0,38 mm kalt / cold	0,33 mm warm

Schmierung & Füllmengen / Lubrification & Capacities

Fahrzeug-Modell / Model	Roadster 62-70	Roadster 72-74	Roadster 75-80	GT 67-71	GT 72-74	Roadster 75-80	empfohlenes Öl / recommend. oil
Kühlsystem / Cooling system - ohne Heizung / w/o heater - mit Heizung / w/ heater	5,35 l 5,6 l	5,35 l 5,6 l	5,6 l 1975-76 6,75 l ab / from 1977	5,35 l 5,6 l	5,35 l 5,6 l	5,6 l / 6,75 l *	
Motor / Oil sump	4,2 l	Frühe Fzge. / Early cars: 4,2 l - mit Ölkühler / w/ oil cooler 4,5 l Späte Fzge. / Late cars: 2,8 l - mit Ölkühler / w/ oil cooler 3,4 l	2,8 l 3,4 l mit Filterwechsel / w/ filter change	4,2 l	Frühe Fzge. / Early cars: 4,2 l - mit Ölkühler / w/ oil cooler 4,5 l Späte Fzge. / Late cars: 2,8 l - mit Ölkühler / w/ oil cooler 3,4 l	2,8 l 3,4 l mit Filterwechsel / w/ filter change	SAE 20W50
Getriebe / Gearbox - ohne Overdrive / non-overdrive - Overdrive / overdrive	2,6 l 2,8 l	2,8 l 3,3 l	2,8 l 3,4 l	2,6 l 2,8 l	2,8 l 3,3 l	2,8 l 3,4 l	Hypoid 80W90
Vergaser / Carburettor	SU HS4 *	SU HIF4 *		SU HS4 *	SU HIF4 *	Stromberg 175CD5T	Motoröl / Motor oil ATF

*) Zylinder des Dämpferkolbens bis zum Rand füllen / Fill cylinder to edge of damper piston

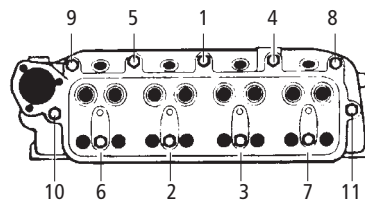

Anziehfolge Zylinderkopfschrauben / Sequence for head bolts

Einstelldaten Motor / Motor data

Fahrzeug-Modell / Model	Roadster + GT 1966-1969
Unterbrecherabstand / Contact breaker gap	0,35-0,40 mm
Zündzeitpunkt v.o.T. / Ignition timing BTDC	
- statisch / static	8° (LC)
- stroboskopisch / stroboscopic	20° @ 1000 rpm
Zündfolge / Engine firing order	1-5-3-6-2-4
Zündkerze Elektrodenabstand / Spark plug gap	0,63-0,66 mm
Leerlaufdrehzahl / Idle speed	
- Manuell / manual	680 rpm
- Automatik Schaltstellung "P" / automatic "P" selected	800 rpm
Ventilspiel / Valve rocker clearance	0,38 mm kalt / cold

Schmierung & Füllmengen / Lubrication & Capacities

Fahrzeug-Modell / Model	Roadster + GT 1966-1969	empfohlenes Öl / recommend. oil
Kühlsystem / Cooling system		
- ohne Heizung / w/o heater	10,2 l	
- mit Heizung / w/ heater	10,5 l	
Motor / Oil sump		
ohne Ölkühler / w/o oil cooler	6,8 l	SAE 20W50
mit Ölkühler / with oil cooler	7,3 l	
Getriebe / Gearbox		Hypoid 80W90
- Standard / standard	3,0 l	
- Overdrive / overdrive	3,4 l	
- Automatik mit Ölkühler / automatic with oil cooler	7,3 l	ATF
Vergaser / Carburettor	SU HS6 *)	Motoröl / Motor oil

*) Zylinder des Dämpferkolbens bis zum Rand füllen /
Fill cylinder to edge of damper piston

Wichtige Anzugsdrehmomente / Important torque wrench settings

Radmuttern (Stahlfelge) / Road wheel (Steel wheel)	8,3 - 9 mkg
Zylinderkopf / Cylinder head	10,4 mkg
Pleuellagerdeckel / Rod bearing	6,9 mkg
Hauptlagerdeckel / Main bearing	10,4 mkg
Schwungrad an Kurbelwelle / Flywheel crankshaft	6,9 mkg

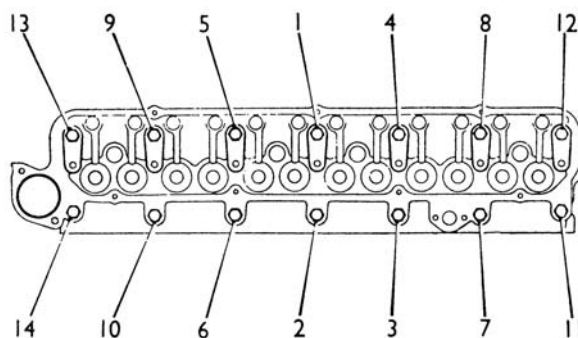

Anziehfolge Zylinderkopfschrauben / Sequence for head bolts

Hinweis  Note:	zu Motorteile ab Seite 4	.. engine parts page 4 ff.

Bitte beachten Sie:
Das Altteil 'Motor' ist uns **ohne** folgende Teile anzuliefern:

- Vergaser und Ansaugstutzen
- Einlaß/Auslaßstehbolzen
- Auspuffkrümmer
- Ventildeckel
- Verteilerantrieb
- Wasserpumpe und Wasserpumpengehäuse
- Thermostatgehäuse
- Lichtmaschine mit Halter
- Keilriemenscheibe
- Stehbolzen Verteiler
- Benzinpumpe
- Stehbolzen Benzinpumpe
- Ölfiltergehäuse

Bitte nicht vergessen:
Öl ablassen und Motor vor Anlieferung außen reinigen!

Please obey: The old engines should be sent to us without the following components: :

- carburetter and intake manifold,
- all manifold studs,
- exhaust manifold,
- valve cover,
- distributor and - drive,
- water pump and -housing,
- thermostat housing,
- alternator,
- v-belt disk,
- fuel pump,
- distributor and fuel pump studs

Don't forget:
Remove the oil and to clean the housing before delivery.

Hinweis  Note:	zu Getriebe ab Seite 44	.. gear box page 44 ff.

Altteile für AT-Getriebe bitte ohne Schalthebel, ohne Ausrückgabel u. -welle, ohne elektr. Schalter und **ohne** Tachoantrieb und in außen gut gereinigtem Zustand anliefern!
Overdrive-Altteile bitte **mit** Tachoantrieb in zusammengebautem, kompletten und außen gut gereinigtem Zustand anliefern!

Bitte nicht vergessen: Öl ablassen!

Please supply us your gear box exchange parts without shifting lever, shifting fork and -shaft, w/o electrical switches and **without** tacho drive.
Please supply us your overdrive exchange parts **with** tacho drive.

Don't forget:
Please remove oil and supply exchange parts mounted, complete and cleaned.

Hinweis  Note:	Overdrive und Differential ab Seite 52 bzw. 58	Overdrive und differential page 52 ff. and 58 ff.

Altteile für AT-Differential bitte wie rechts abgebildet in komplettem und gut gereinigtem Zustand anliefern!

Bitte nicht vergessen: Öl ablassen!

Please supply us your differential exchange as shown in figure on the right, complete and cleaned.

Don't forget:
Please remove oil and supply exchange parts mounted, complete and cleaned.

Abb.: AT-Motor / Fig.: Engine, exchange



Abb. 4-Zyl. / Fig. 4-cyl.

Abb.: AT-Getriebe / Fig.: Gear box, exchange



ohne / no overdrive

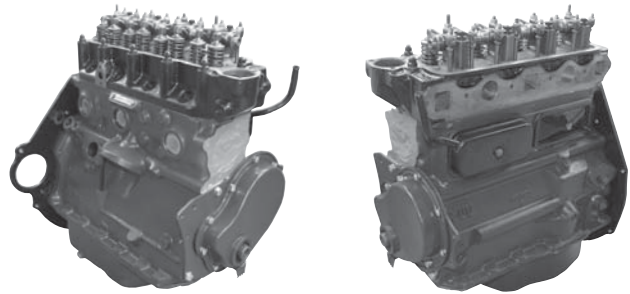
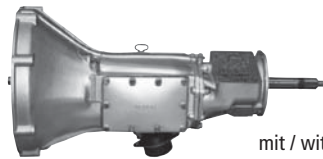

mit / with overdrive

Abb.: AT-Overdrive / Fig.: Overdrive, exchange



3-Synchro D-Type



4-Synchro LH-Type

Abb.: AT-Differential / Fig.: Differential, exchange



"Banjo Type"



"Tube Axle"